

schematics
block diagrams
rear views
dimensions and weights

V12 mixing console

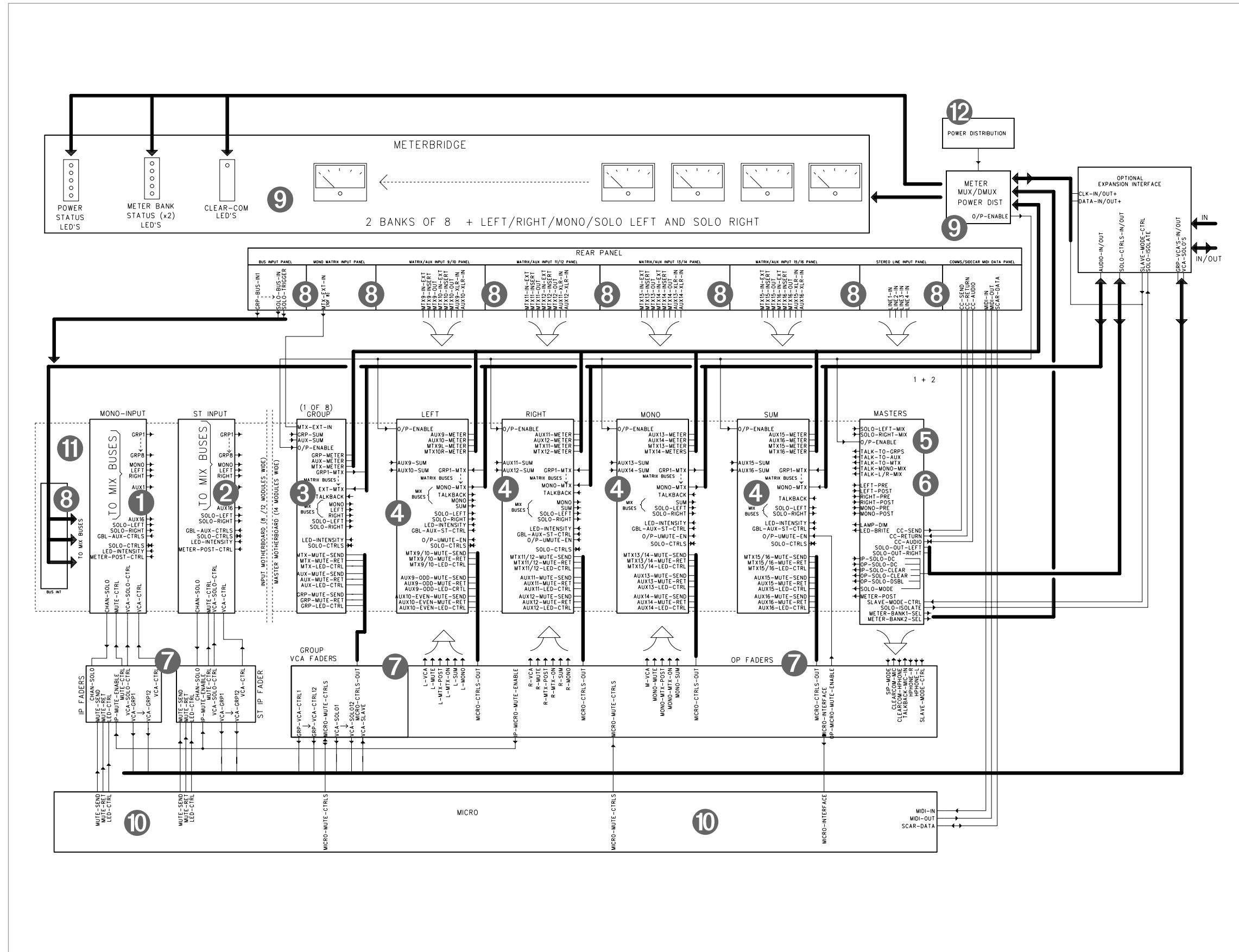



mono inputs p. 3

1

stereo inputs p. 13

2

groups p. 26

3

outputs p. 33

4

master 1 p. 42

5

master 2 p. 48

6

faders p. 54

7

connectors p. 63

8

meters p. 73

9

micro muting system p. 77

10

motherboards p. 83

11

power supply p. 86

12

mono input—block diagram

mono inputs
connector PCB
main PCB
main sub PCB

see p. 3

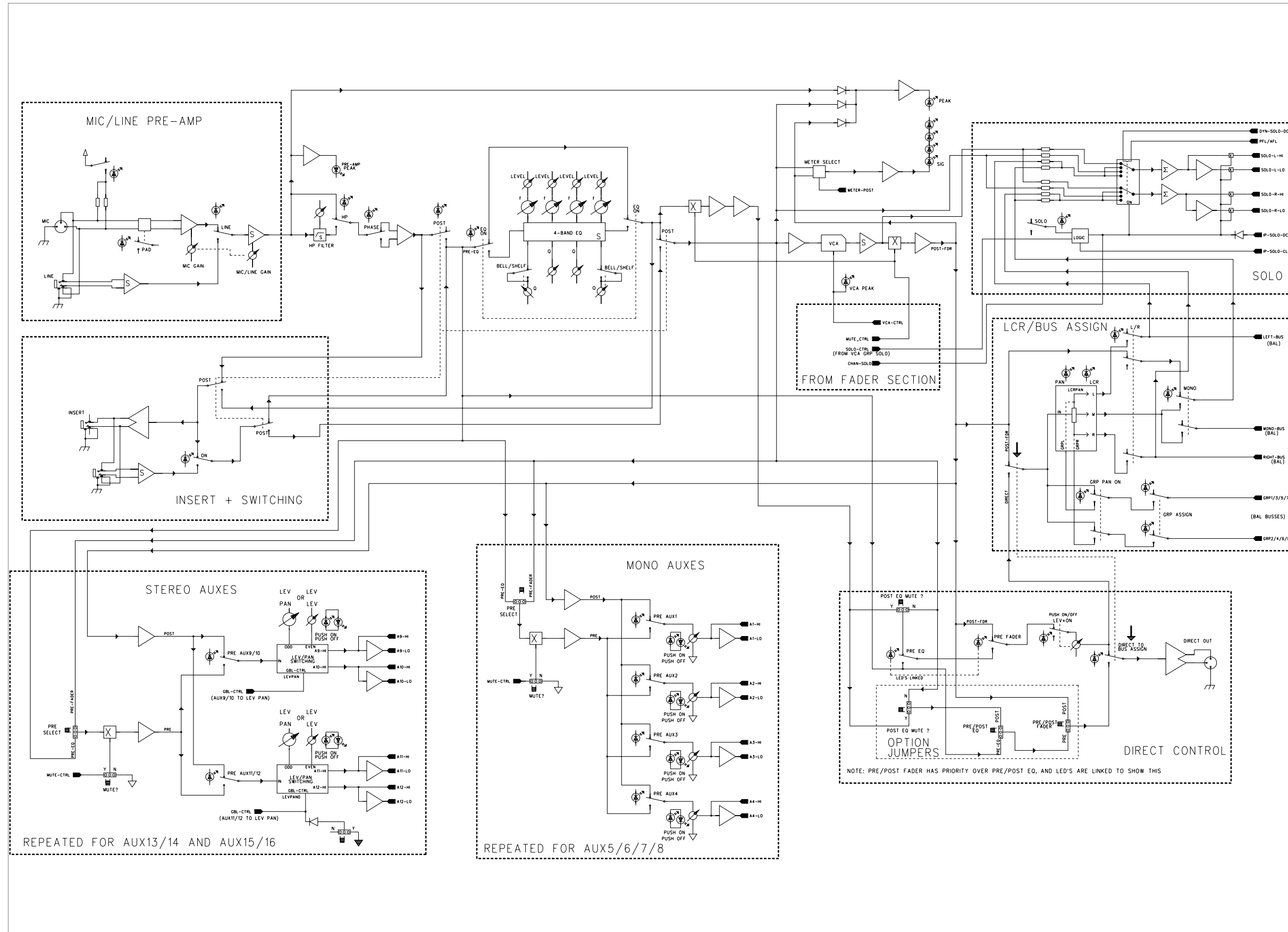

stereo input—block diagram

stereo inputs see p. 13
 connector PCB
 connector sub PCB
 main PCB
 main sub PCB

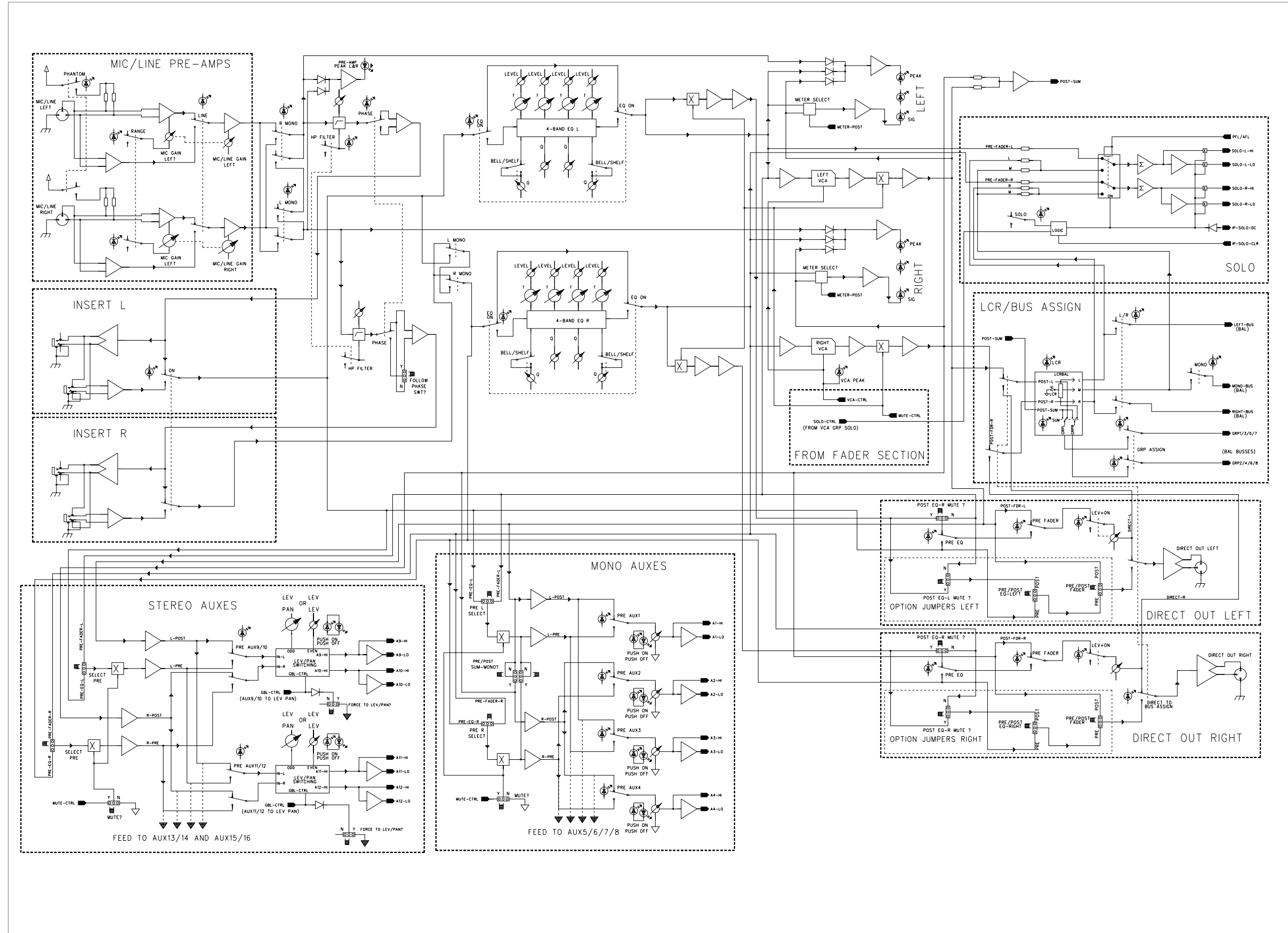

groups
audio sub PCB
connector PCB
main PCB
main sub PCB

see p. 26

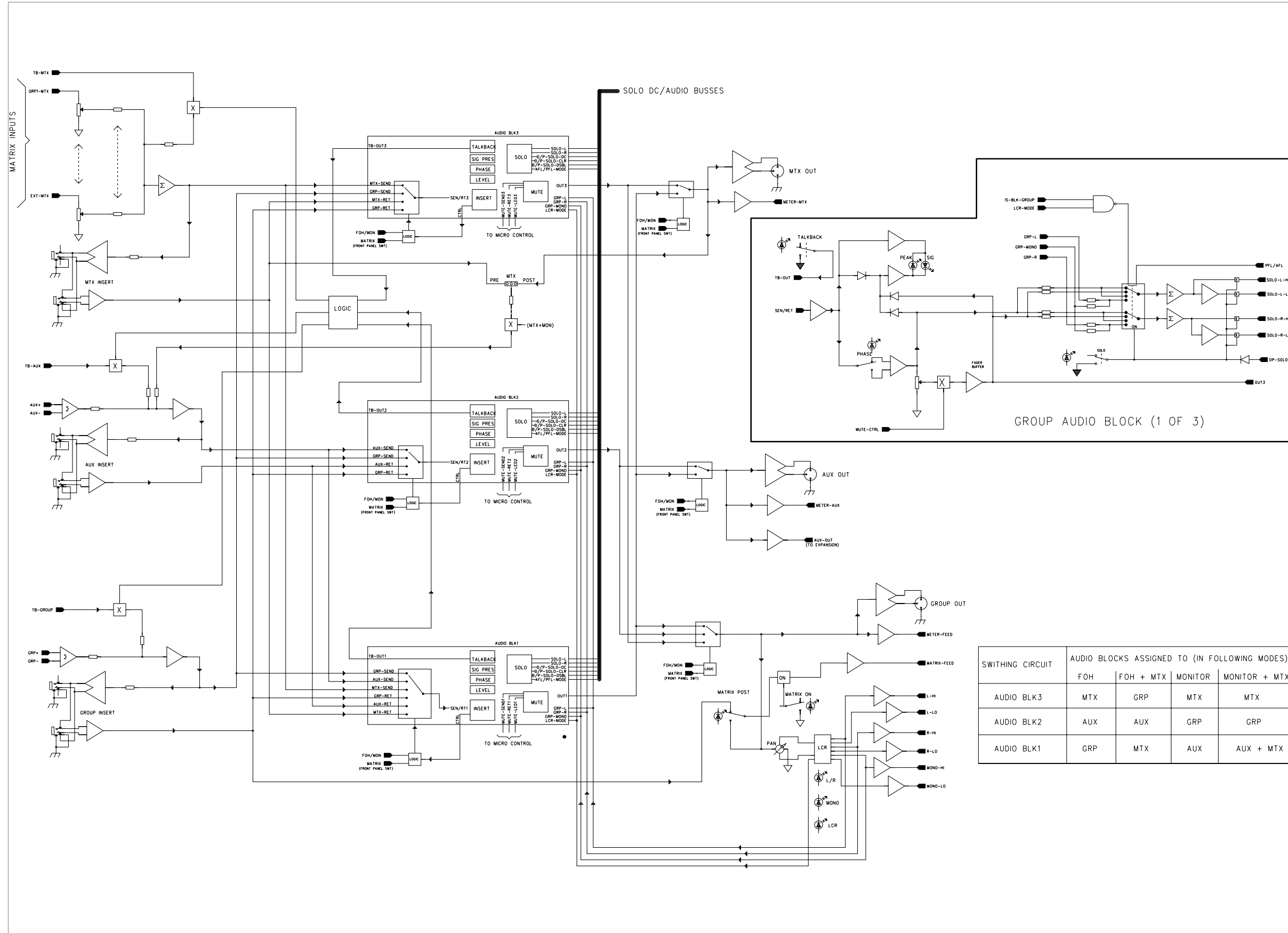

SWITCHING CIRCUIT	AUDIO BLOCKS ASSIGNED TO (IN FOLLOWING MODES)			
	FOH	FOH + MTX	MONITOR	MONITOR + MTX
AUDIO BLK3	MTX	GRP	MTX	MTX
AUDIO BLK2	AUX	AUX	GRP	GRP
AUDIO BLK1	GRP	MTX	AUX	AUX + MTX

output module—block diagram

outputs
connector PCB
main PCB
main sub PCB

see p. 33

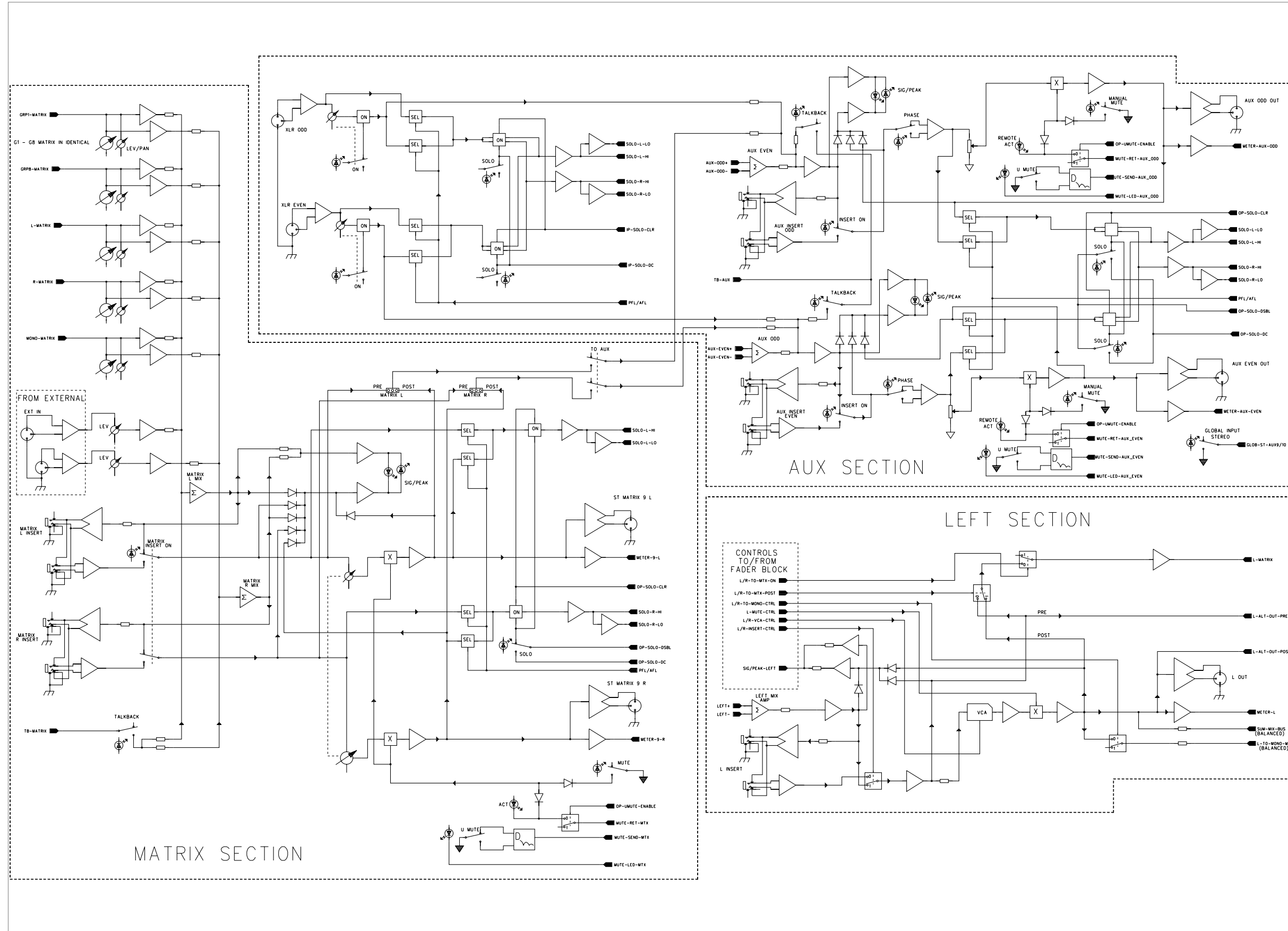

master 1 module—block diagram

6-of-11

section 5

master 1
connector PCB
main PCB
main sub PCB

see p. 42

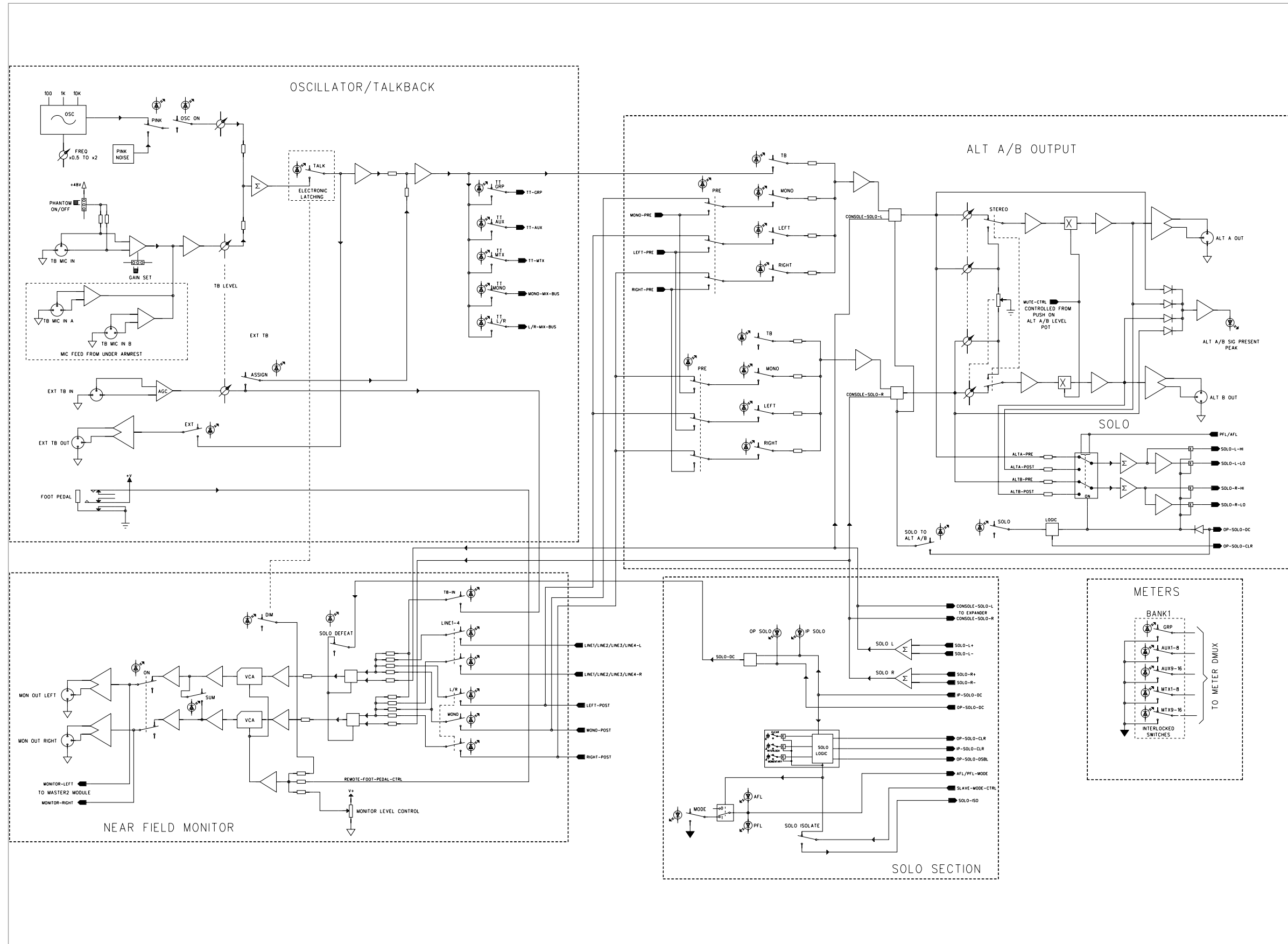

master 2
connector PCB
main PCB
main sub PCB

see p. 47

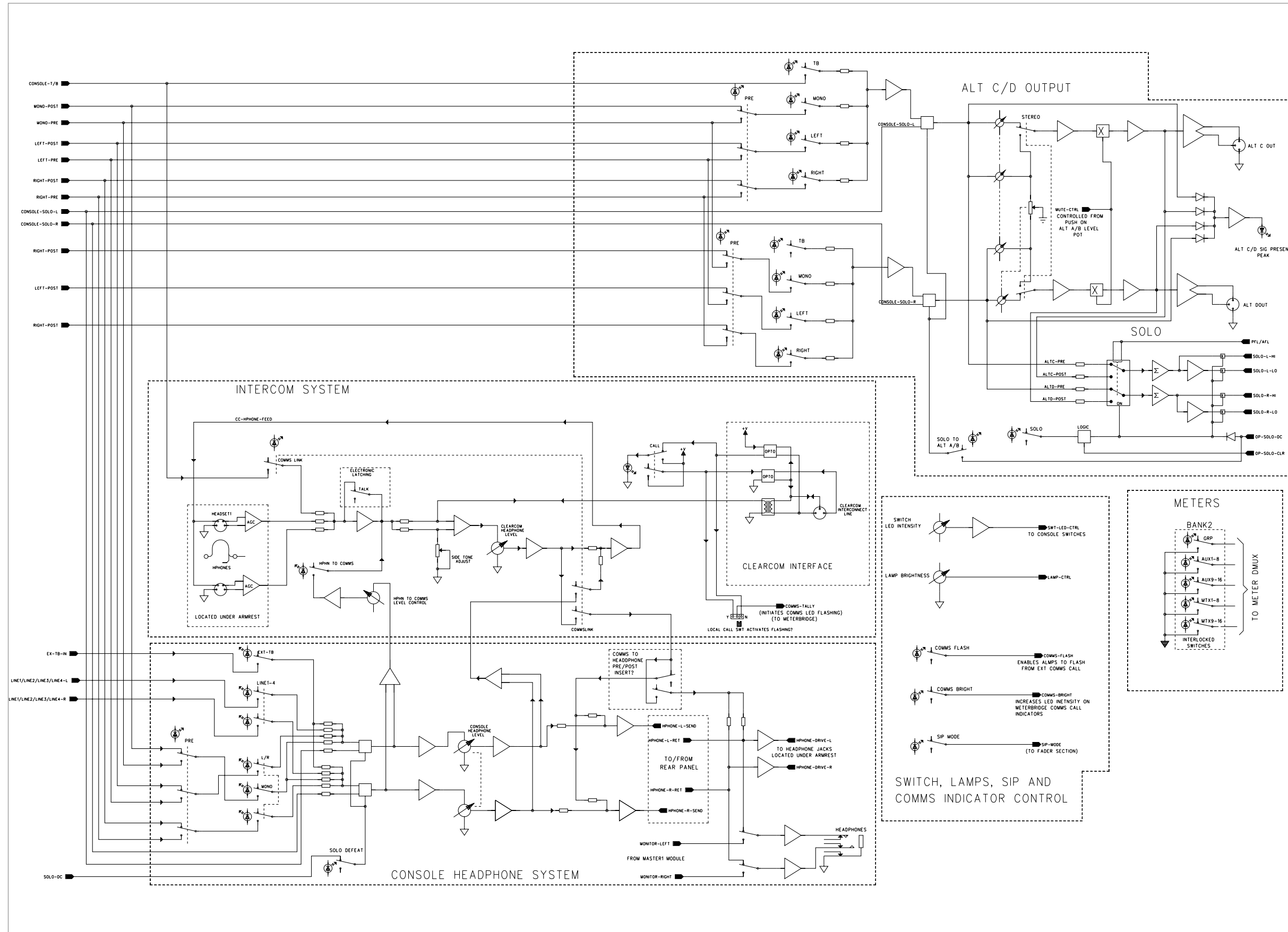

faders
fader PCB
fader mute PCB

see p.53

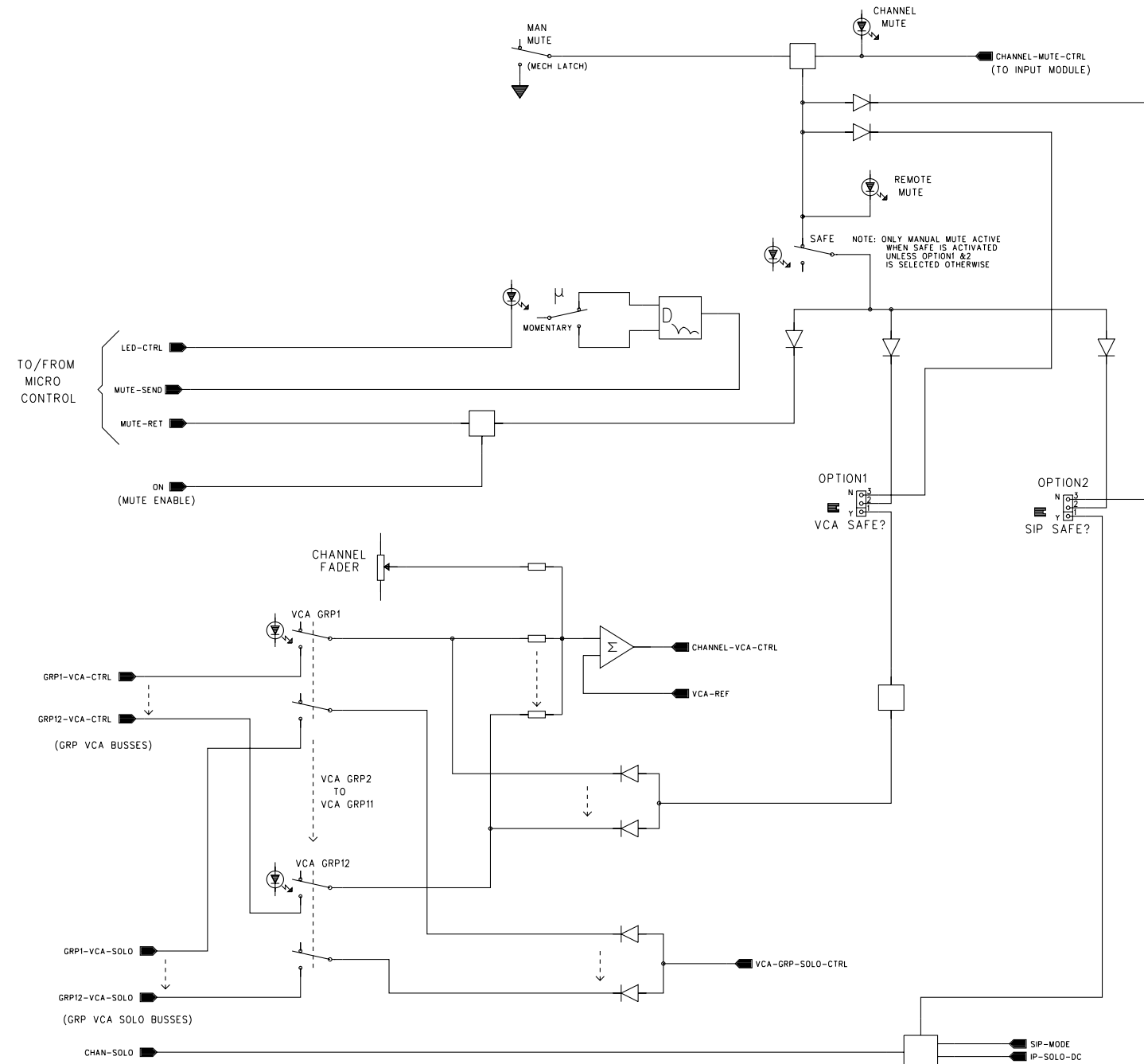

faders see p. 62
 master VCA mute PCB
 master VCA solo PCB
 output control PCB

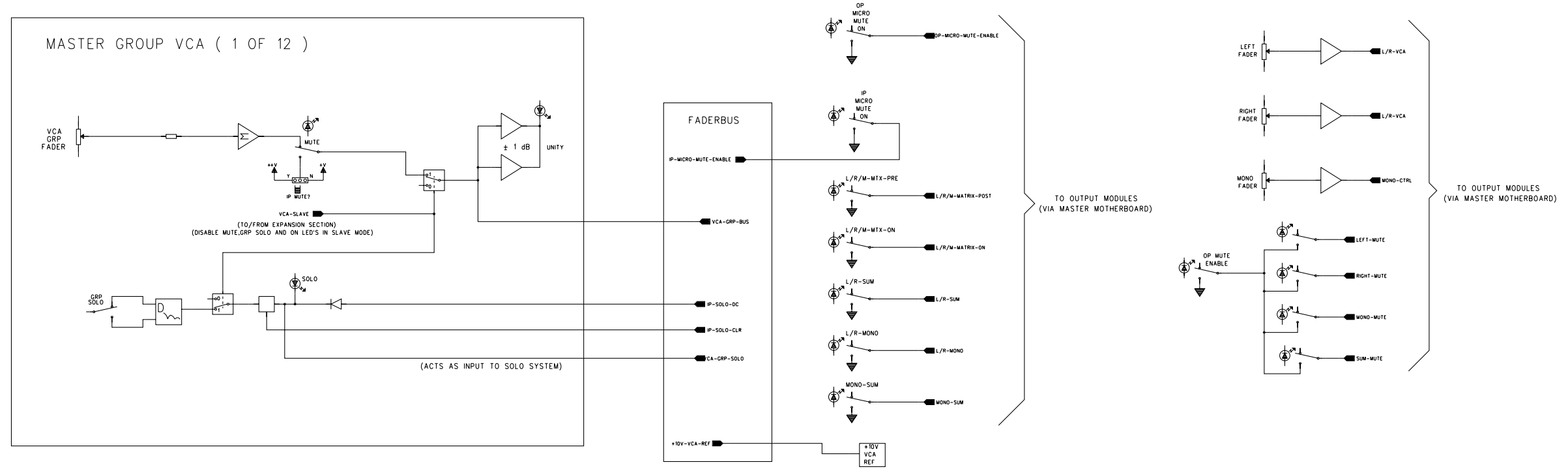

NOTE: THE MASTER MICRO INTERFACE PCB (LOCATED BELOW THIS SECTION ON THE FADER TRAY) DIRECTS MUTE SIGNALS FROM/TO THE MICRO SECTION AND THE MASTER MODULES.

meter system—block diagram

meters see p. 71
 multiplexer/dimmer/fan control PCB
 de-multiplexer PCB
 indicator PCB

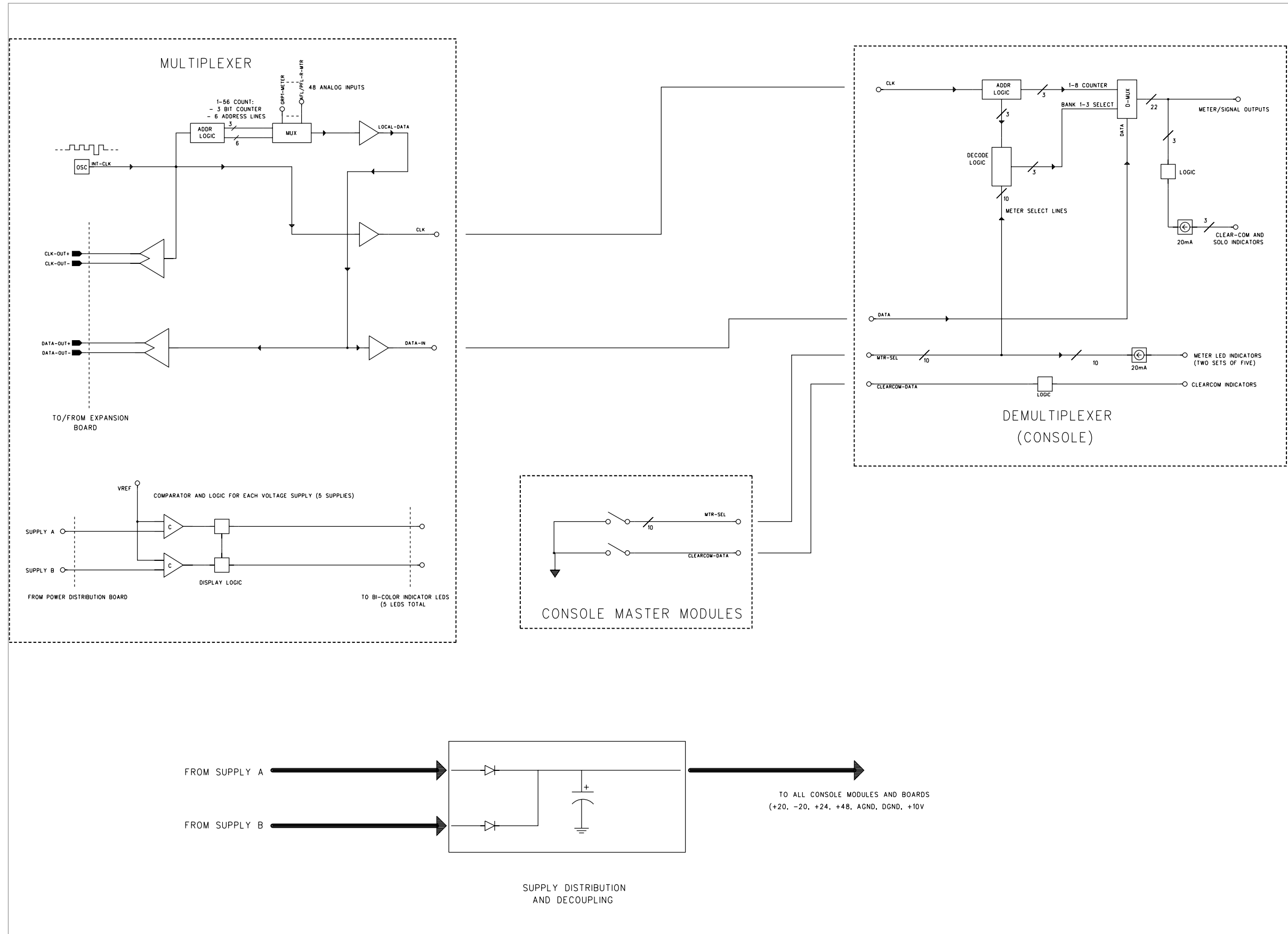

power supply see p. 1
 power distribution PCB
 display PCB
 negative HS PCB
 positive HS PCB

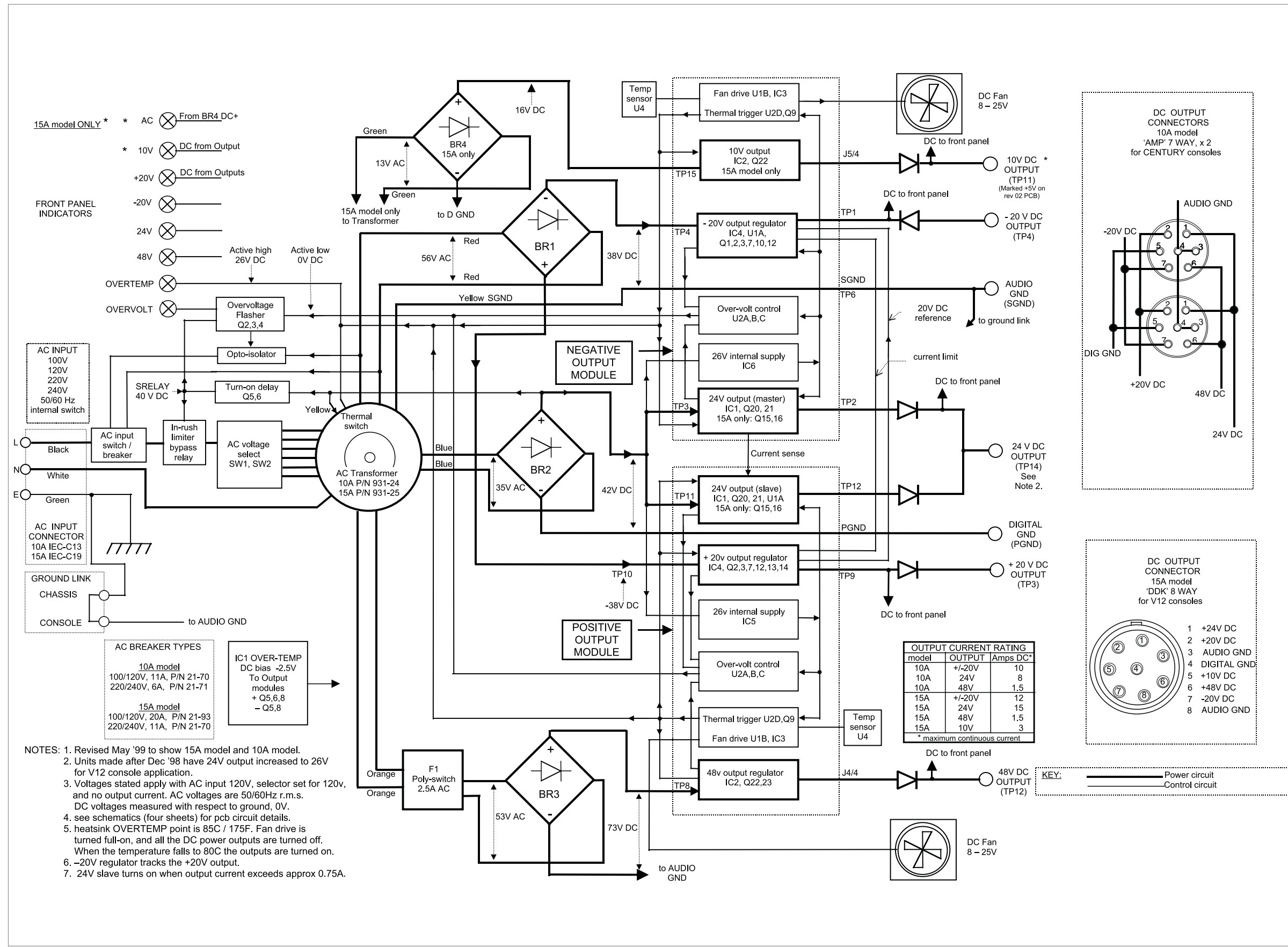

console dimensions and rear-view

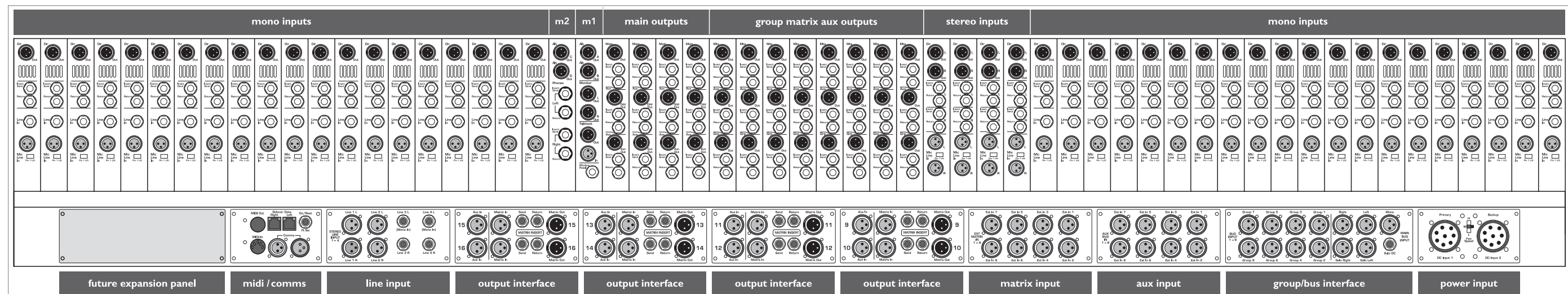
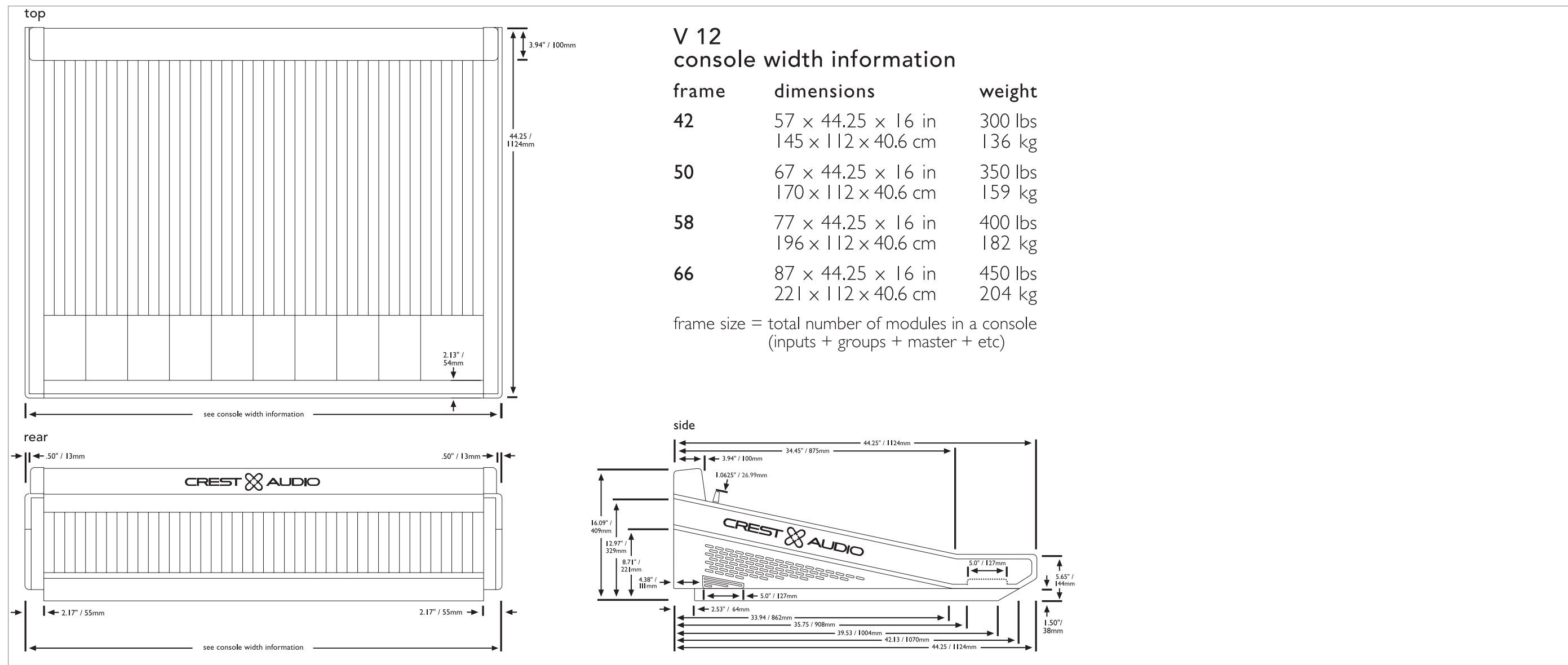

console rear-view (enlarged)

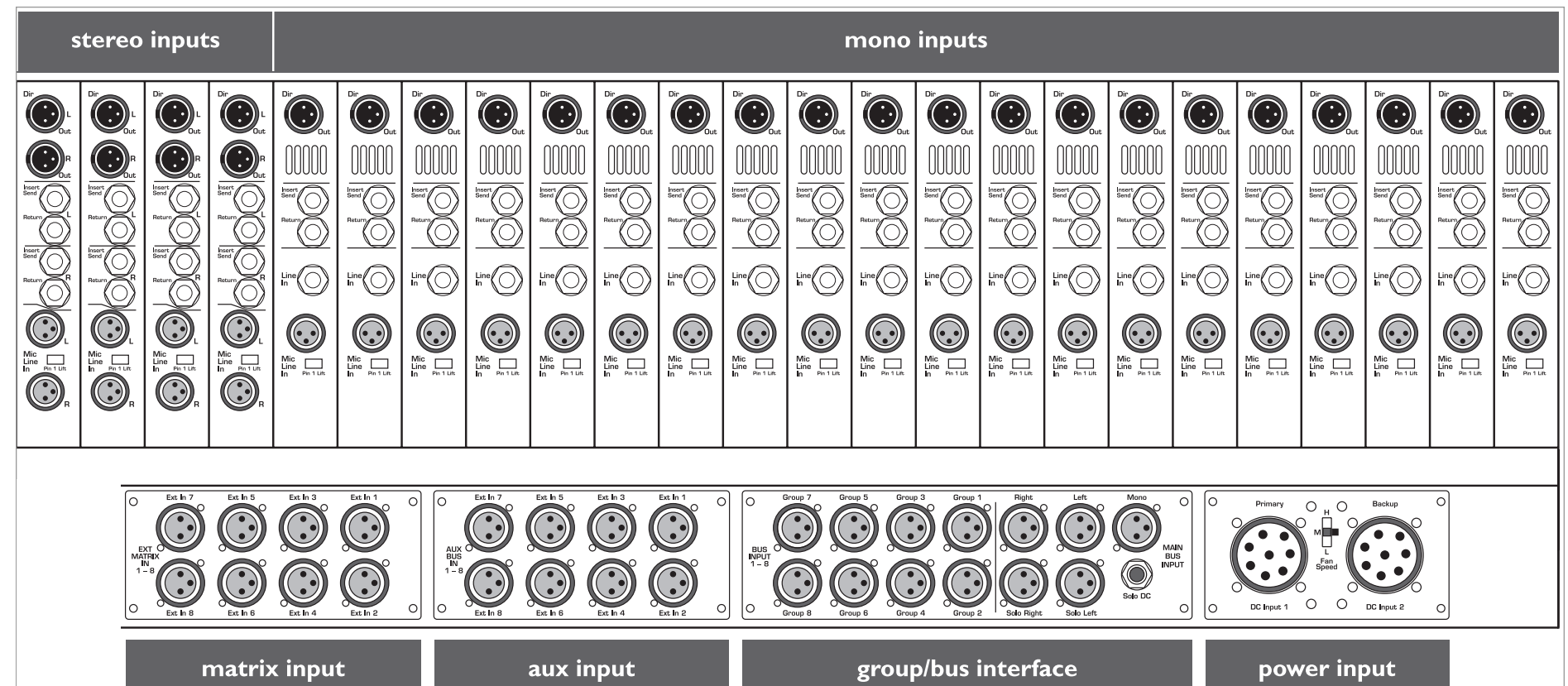
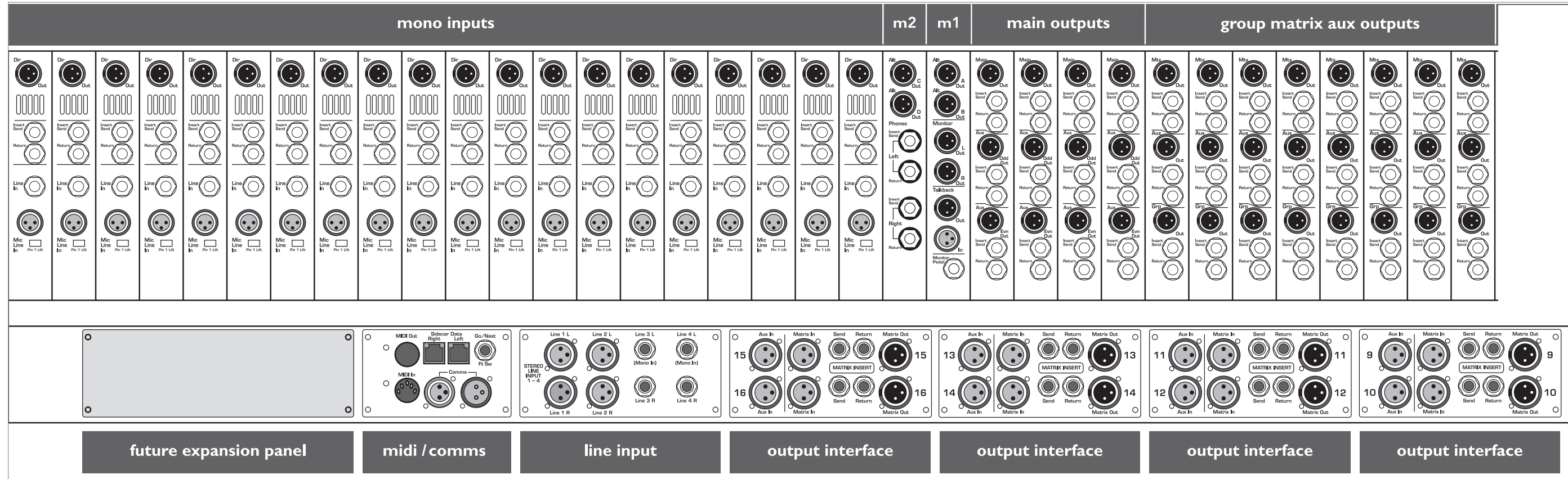

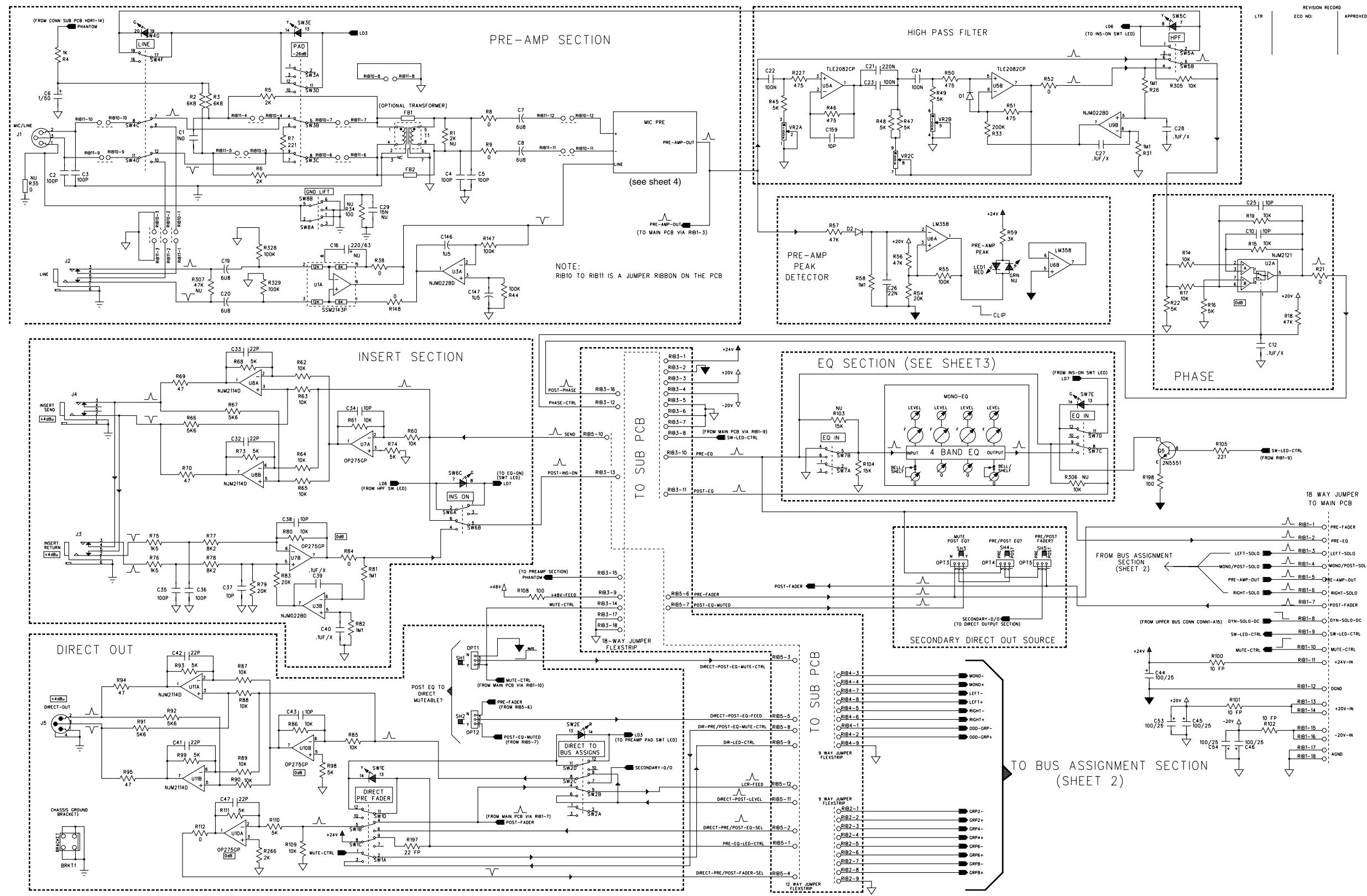

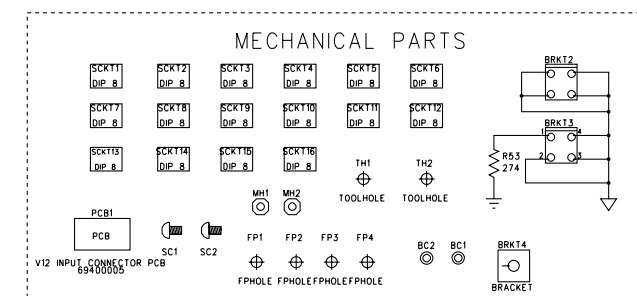
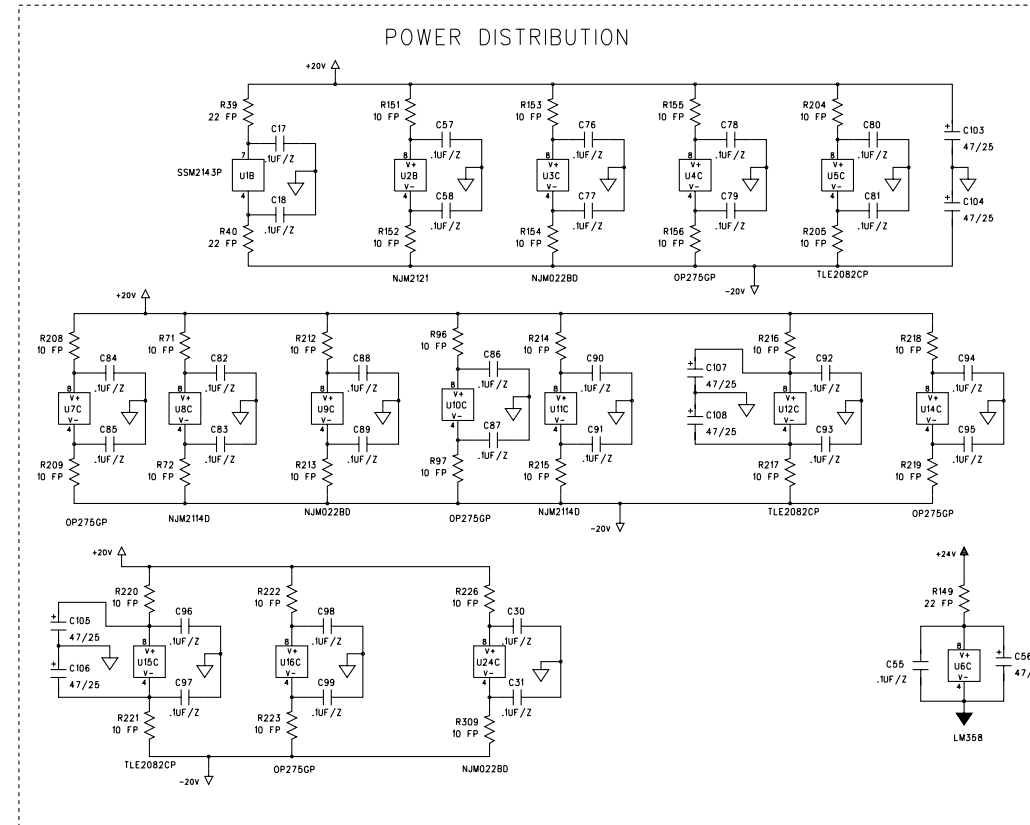
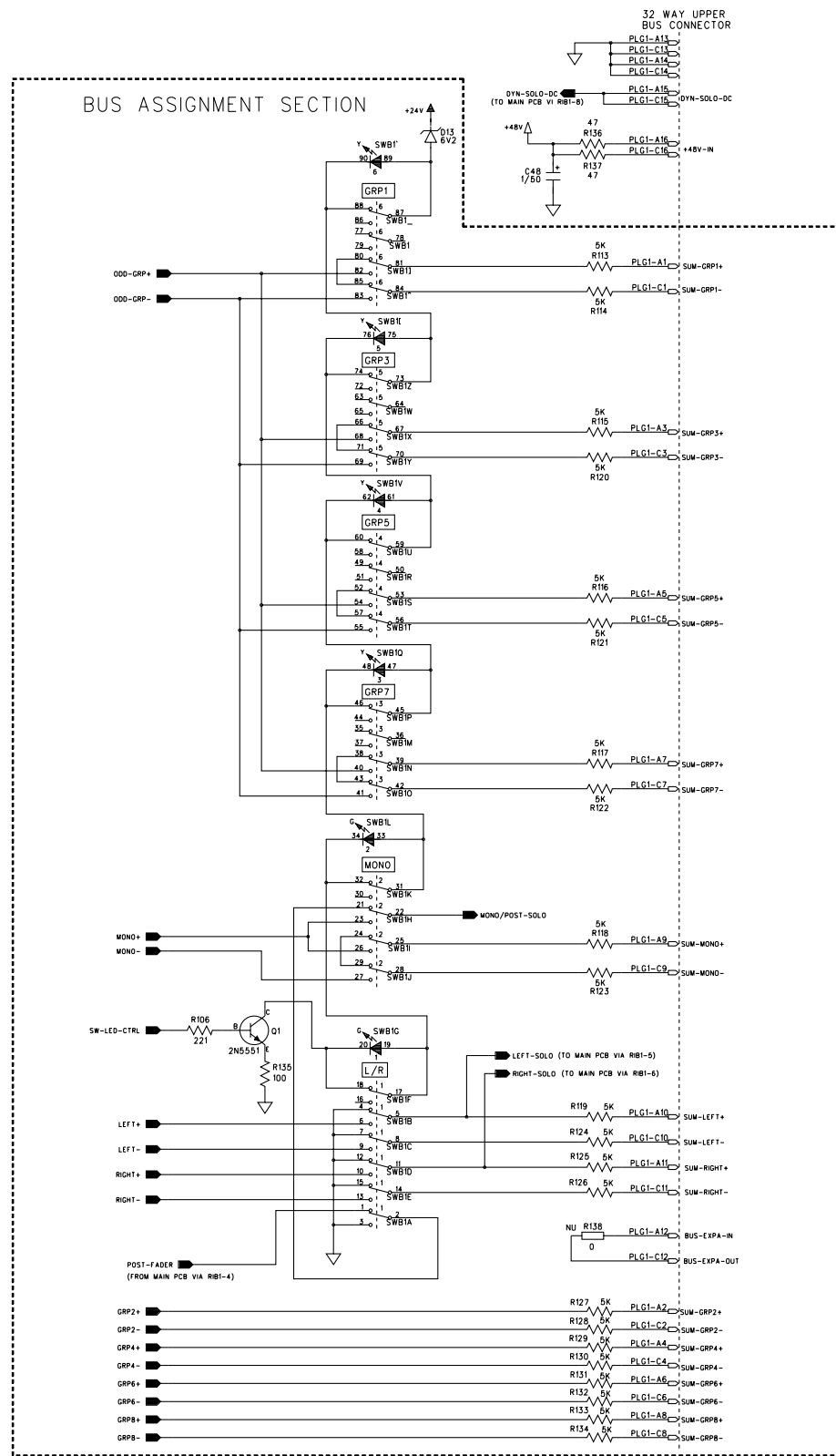

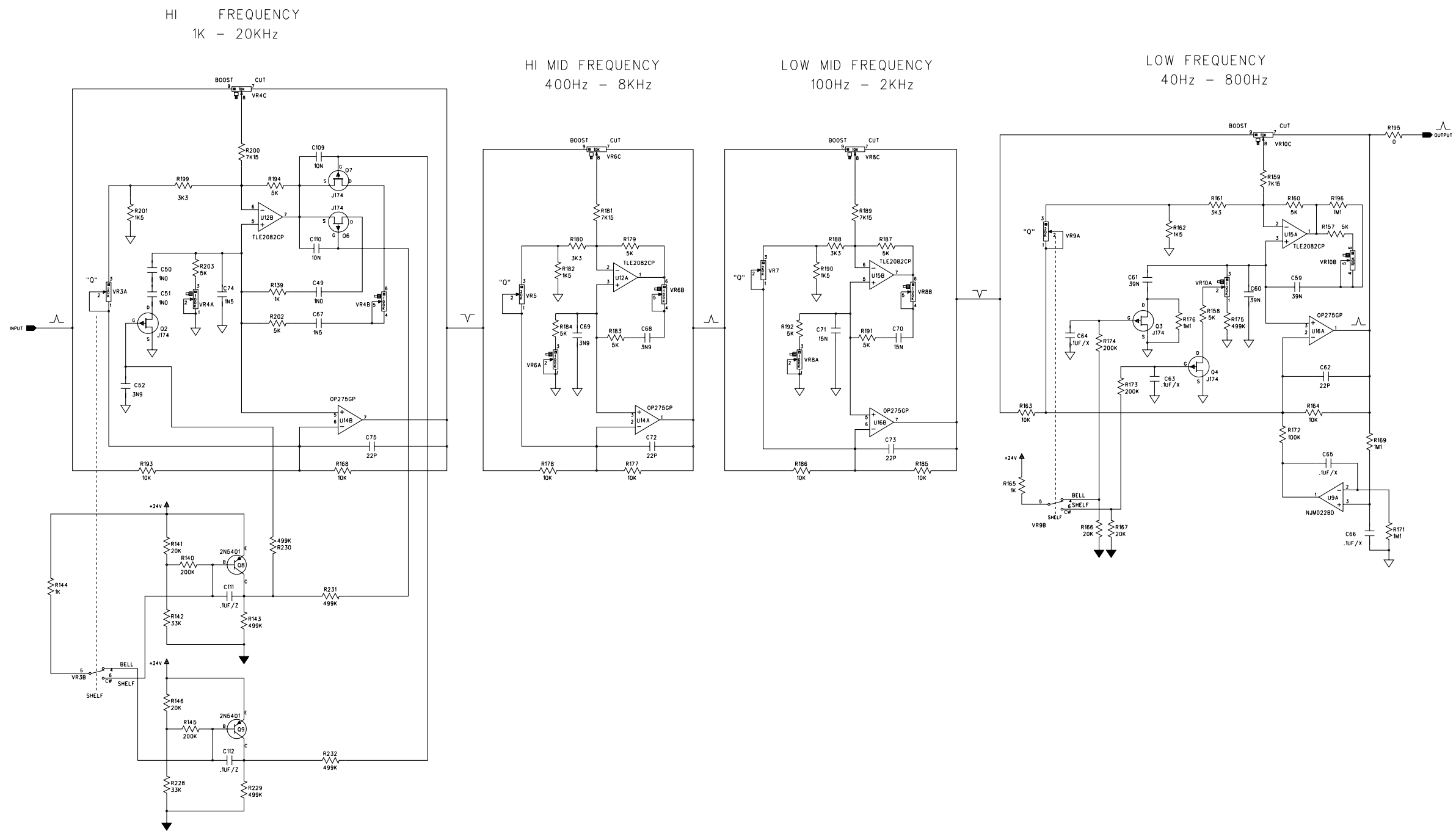

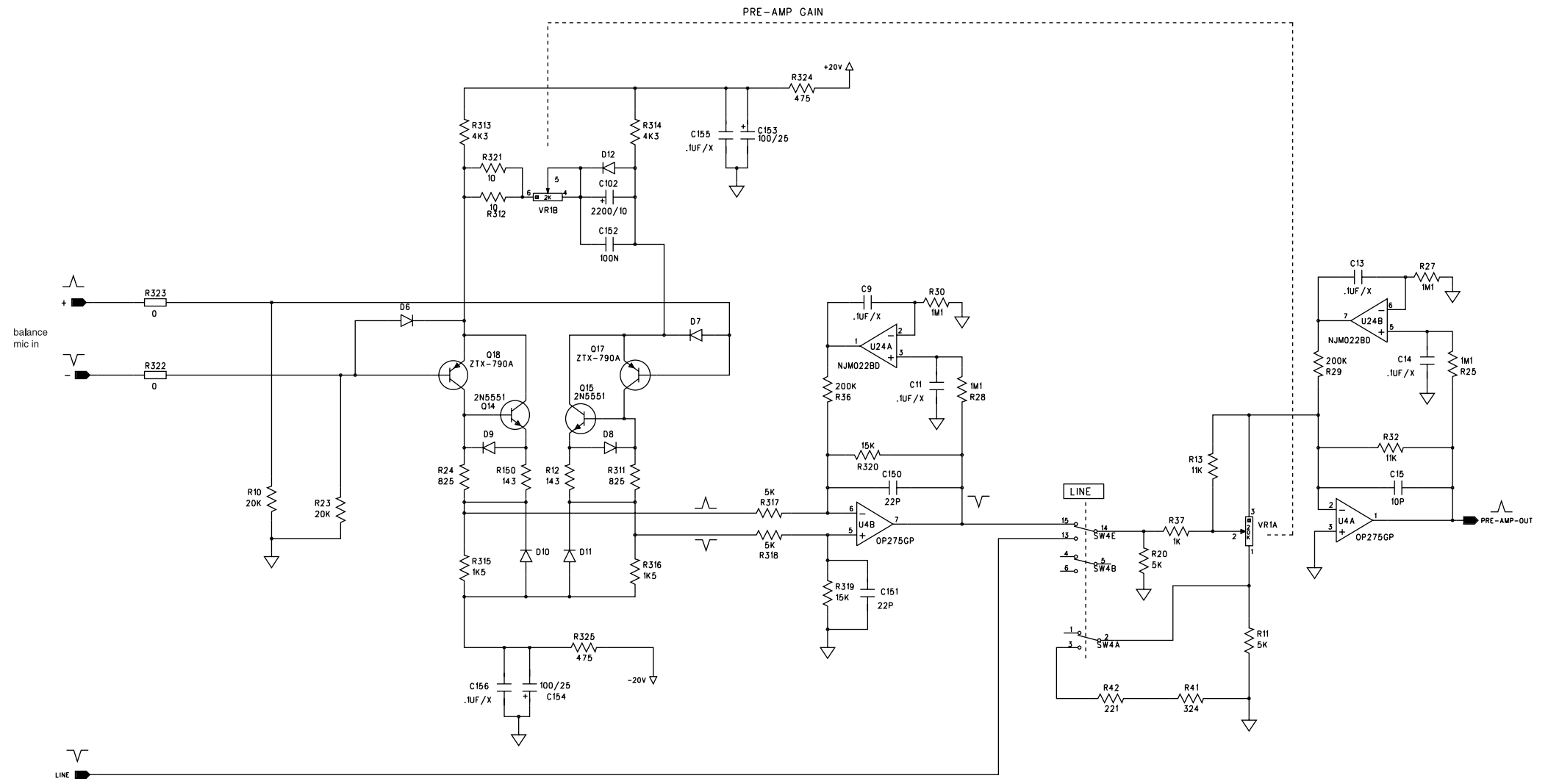

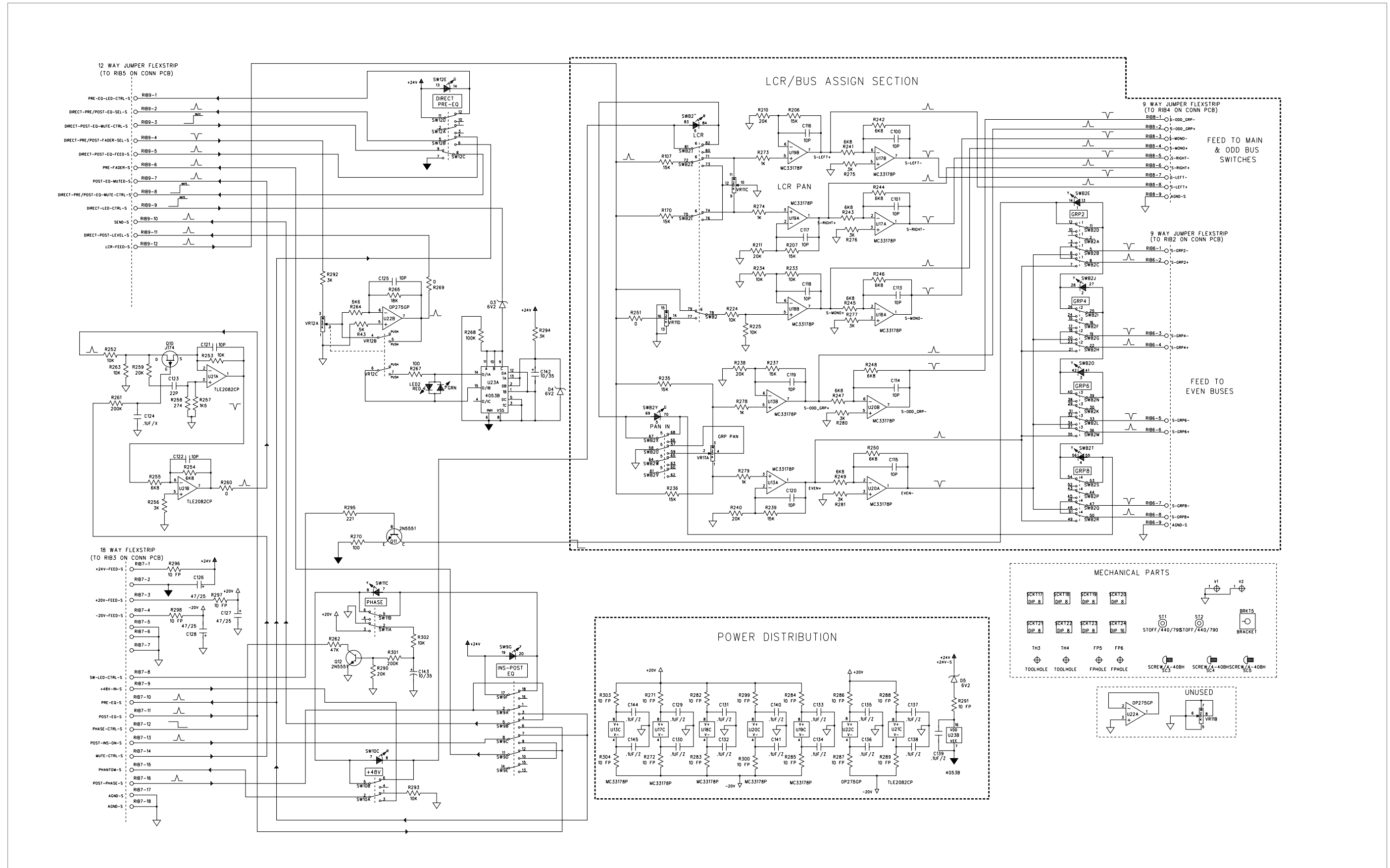

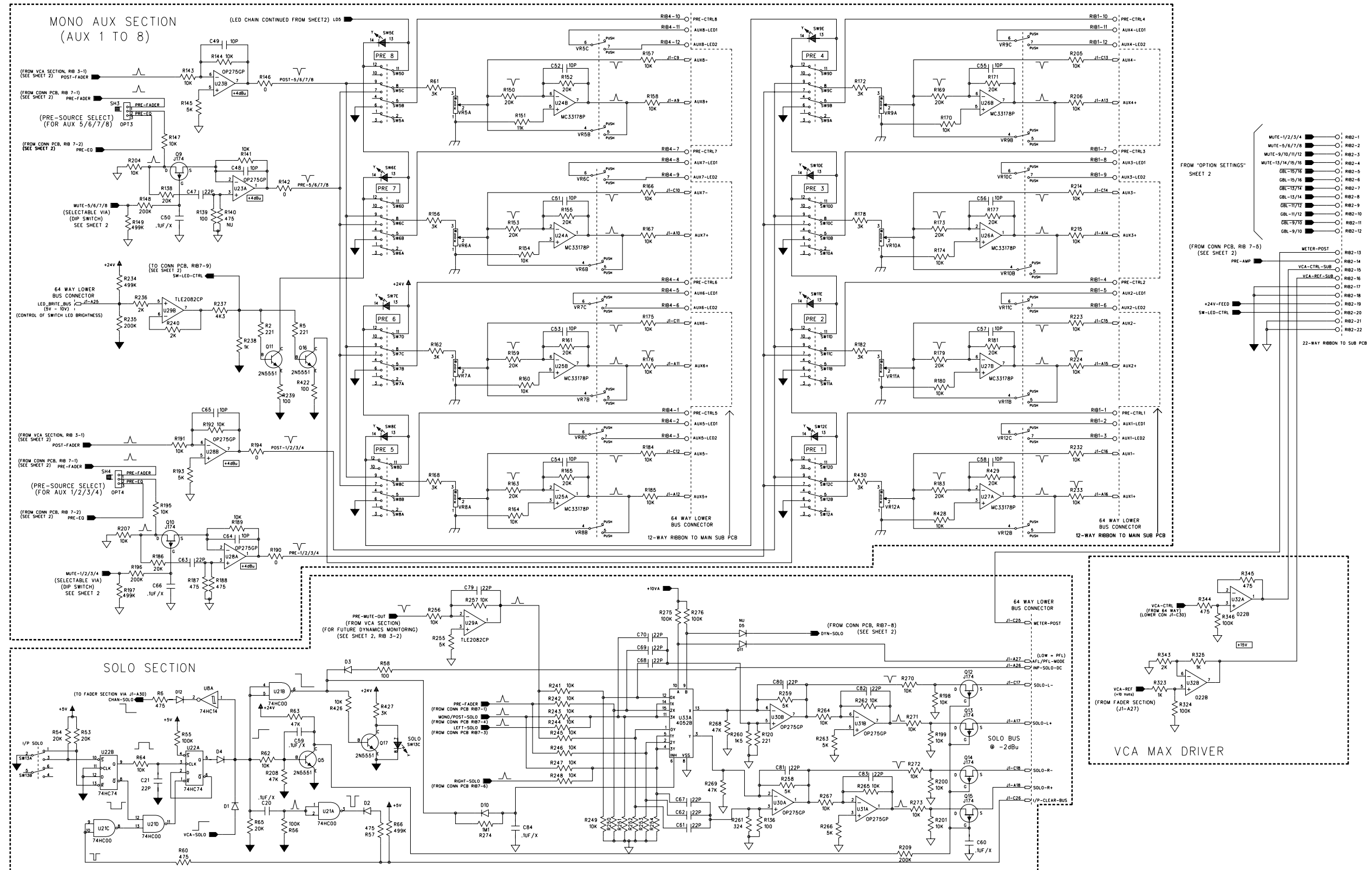

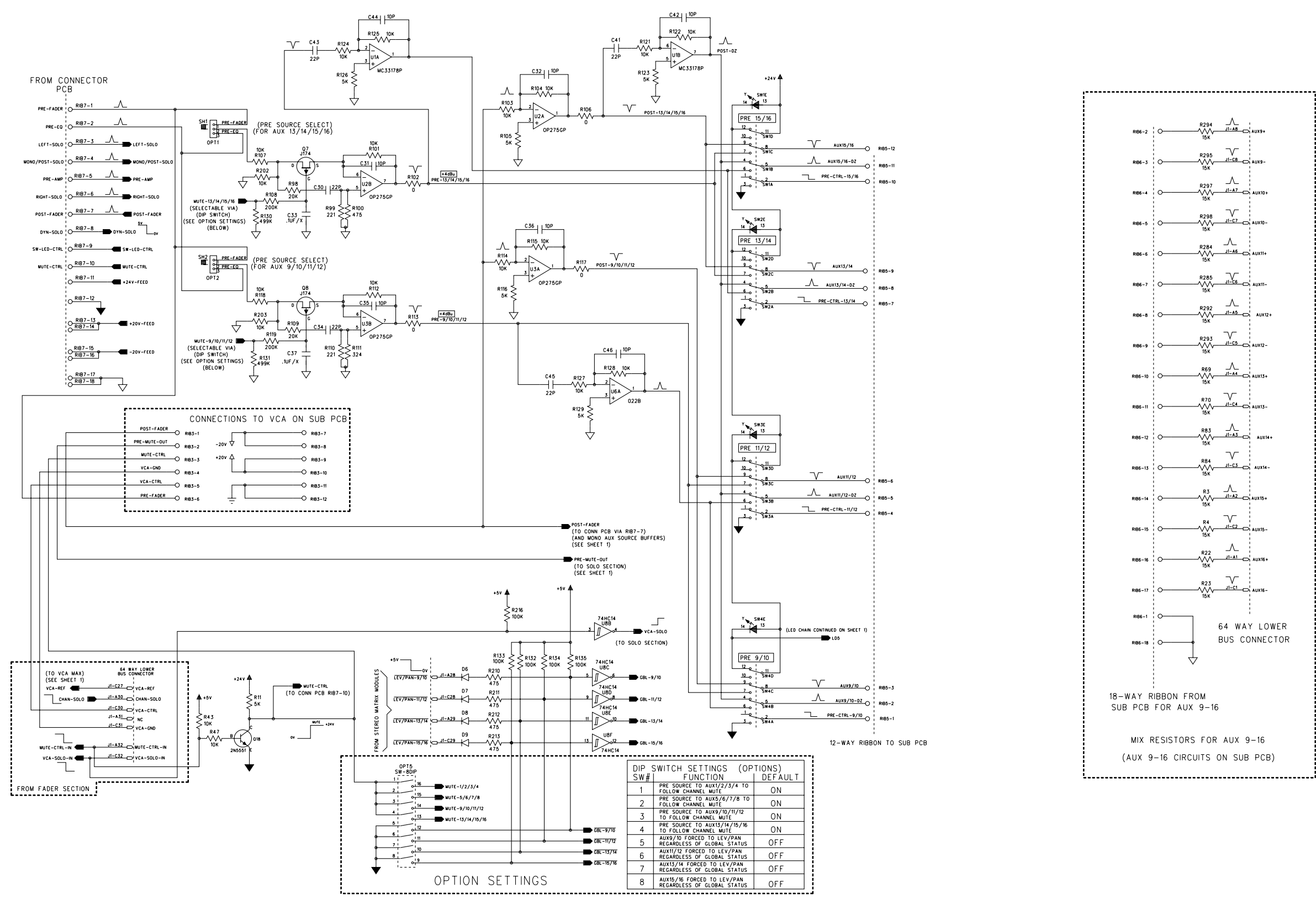

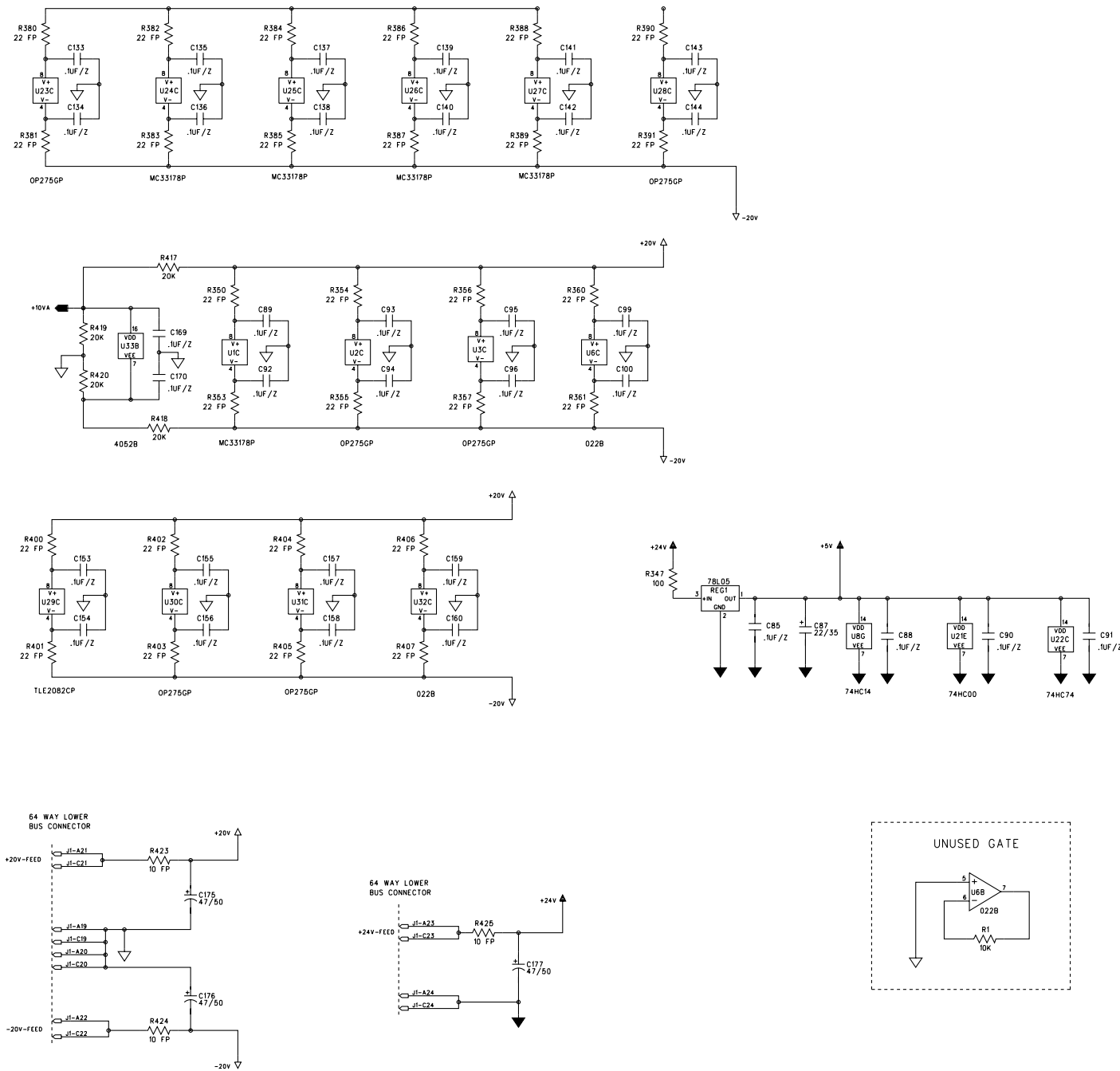

DCO/ECO #	CHANGE DESCRIPTION	PARTS CHANGED	ENGINEER
dc0775	AUX 5/6/7/8 PRE AUX MUTE TRIM SOLO CROSSTALK TRIM	R140 FROM 475R TO NU R139 FROM 221R TO 100R0 R260 FROM 4K99 TO 1K50 R120 FROM 1K0 TO 221R R261 FROM 4K99 TO 324R R136 FROM 1K0 TO 100R0	TAZ

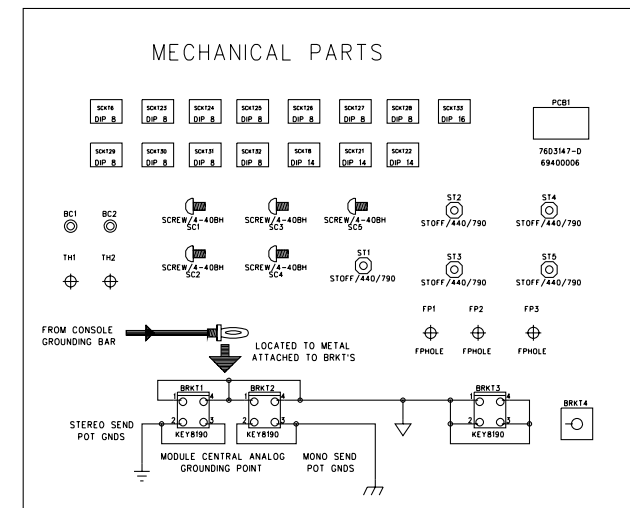

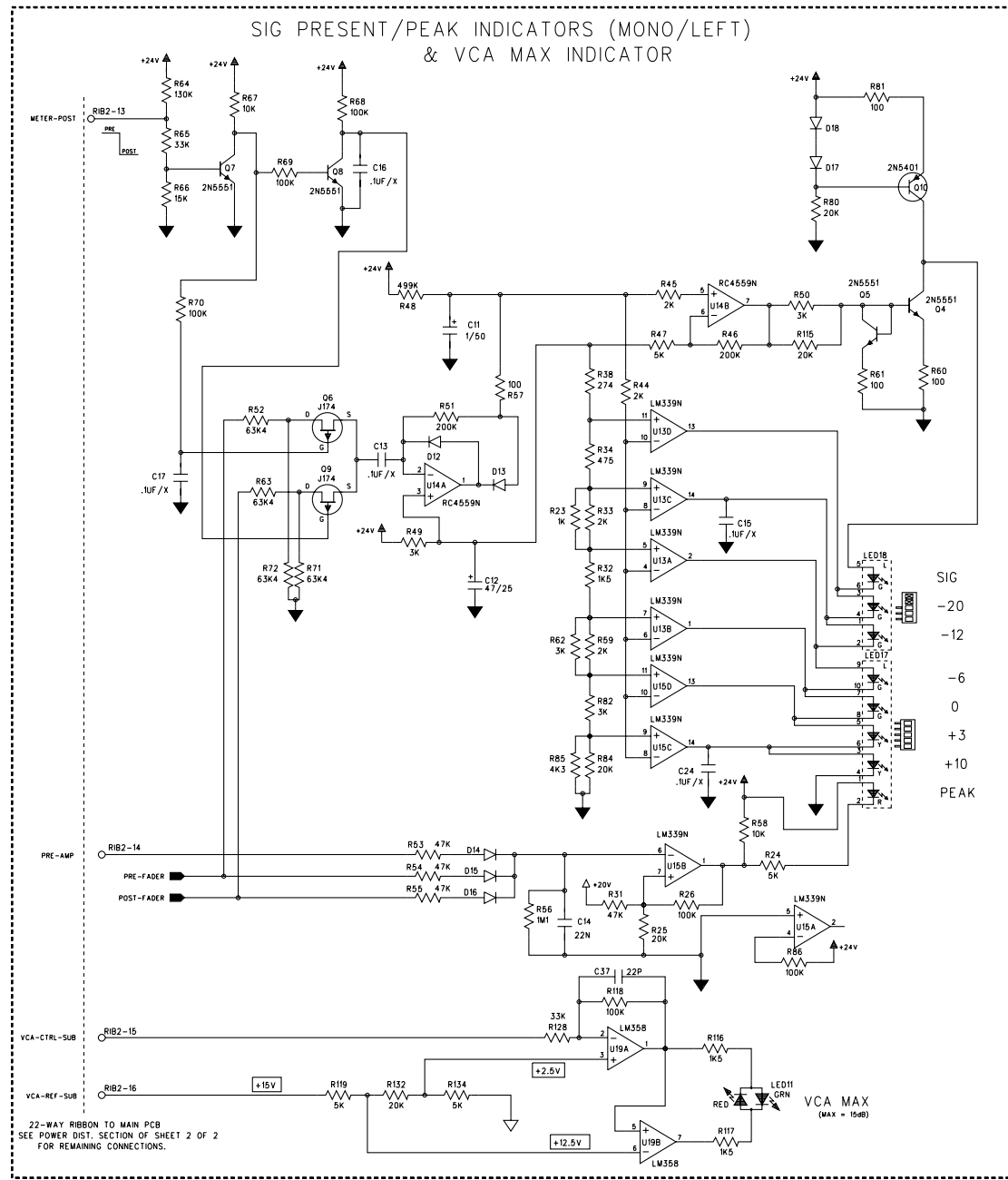
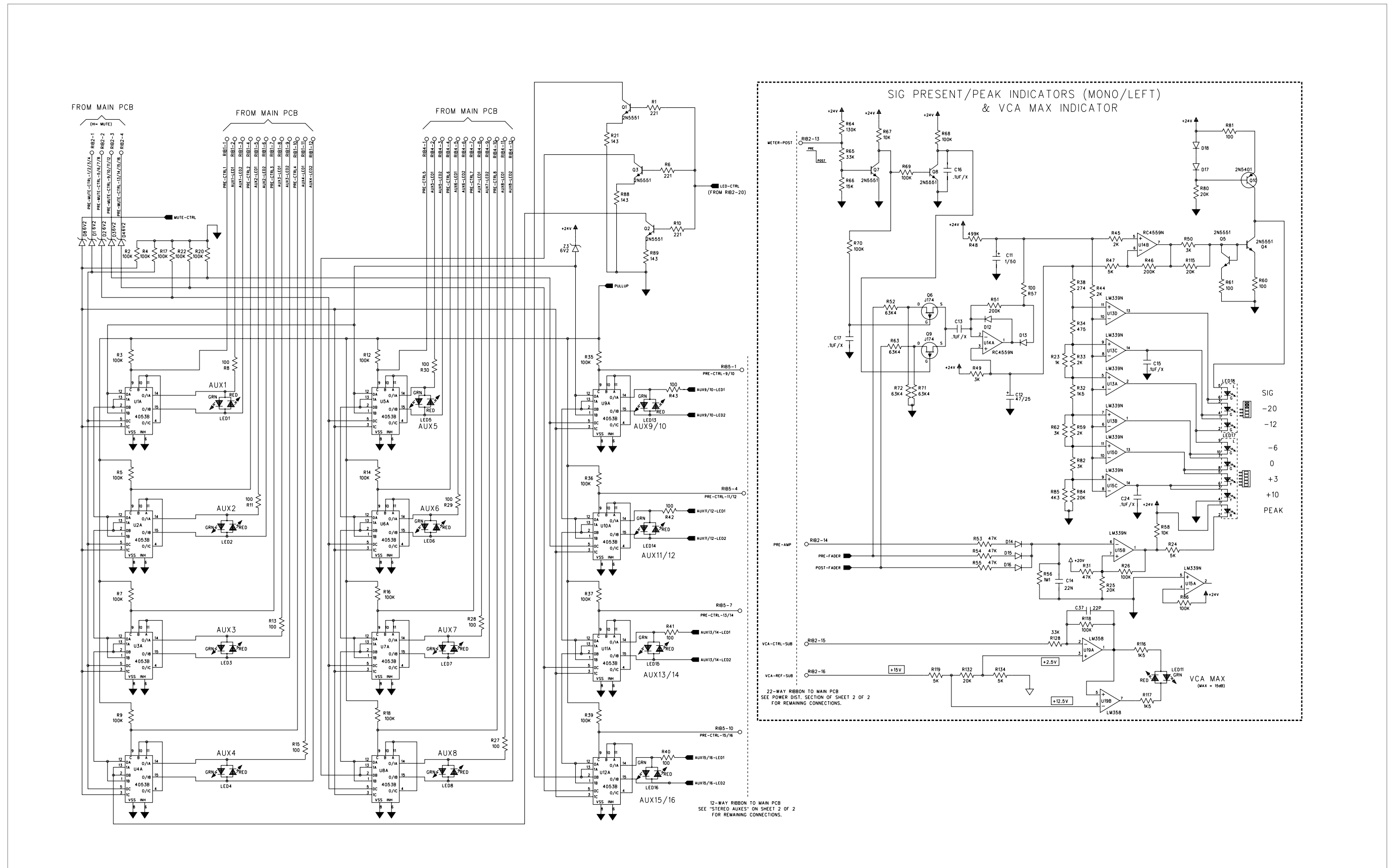

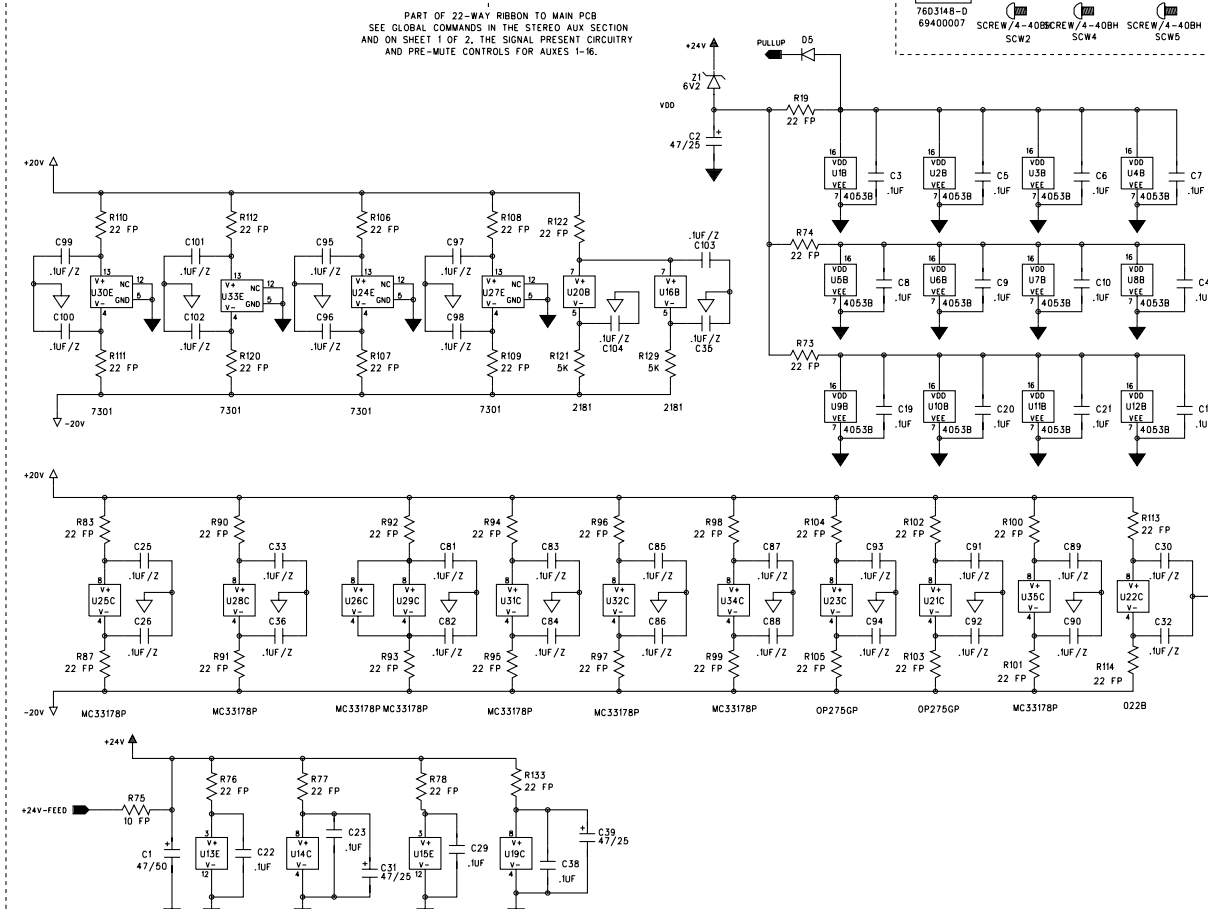
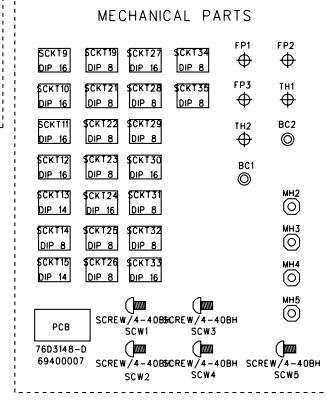
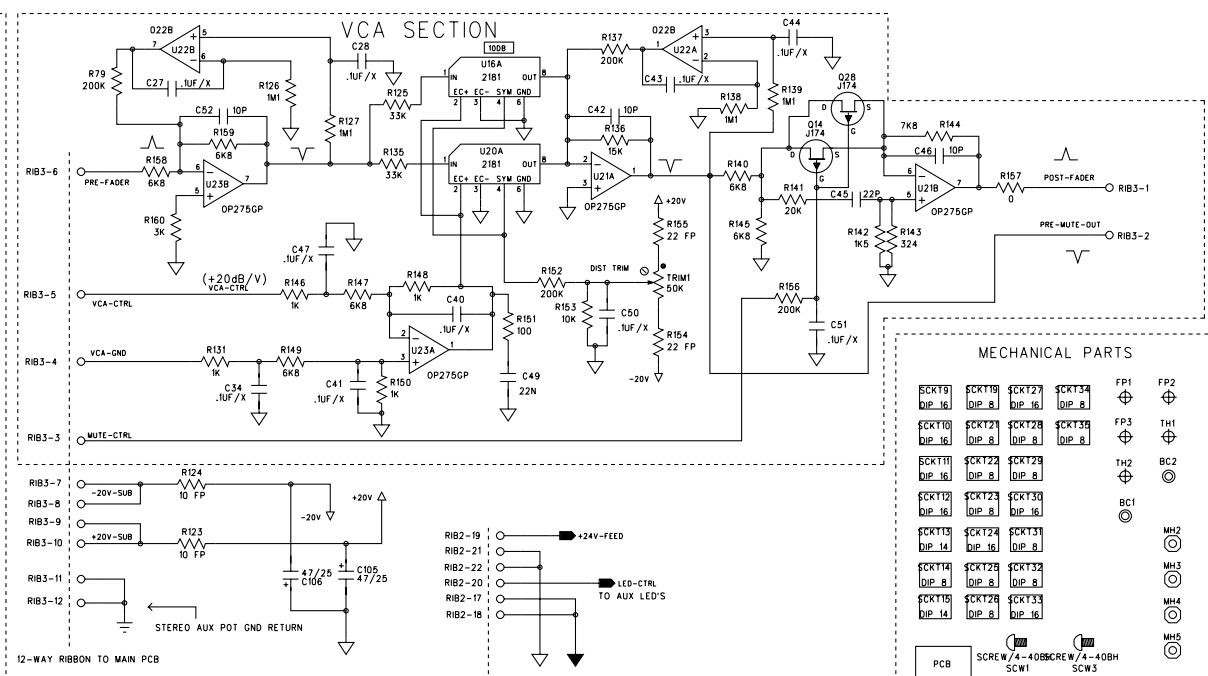
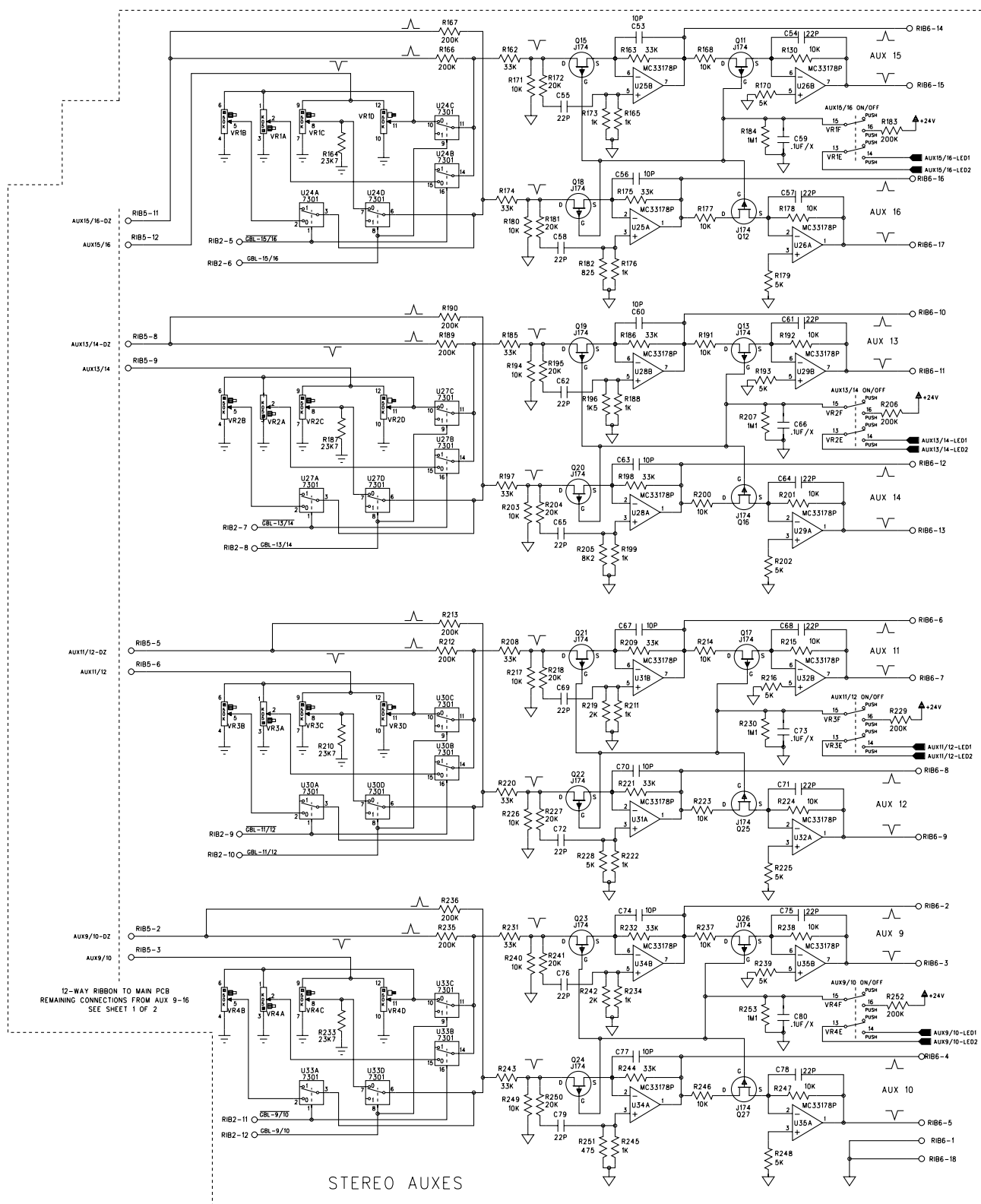

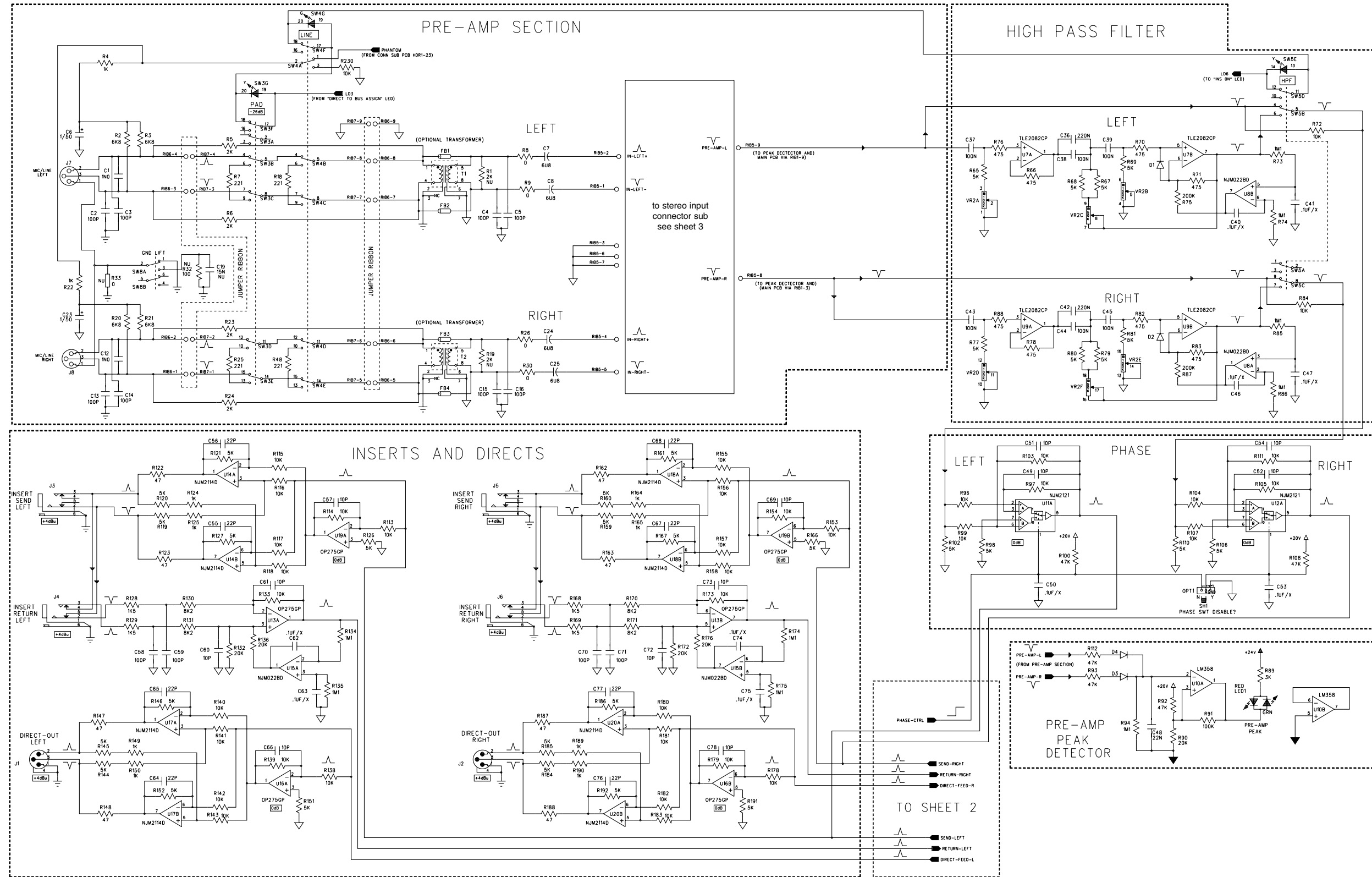

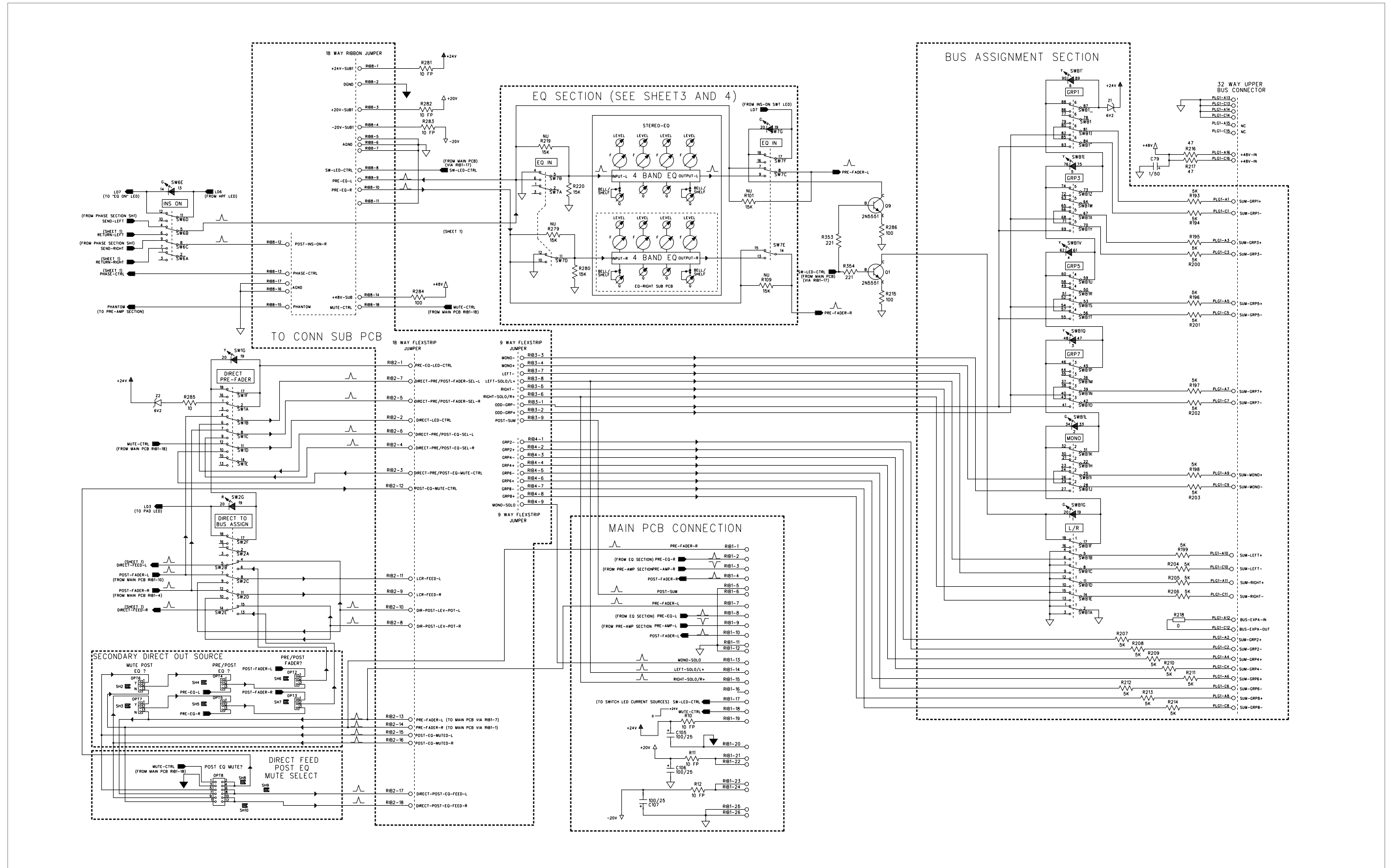

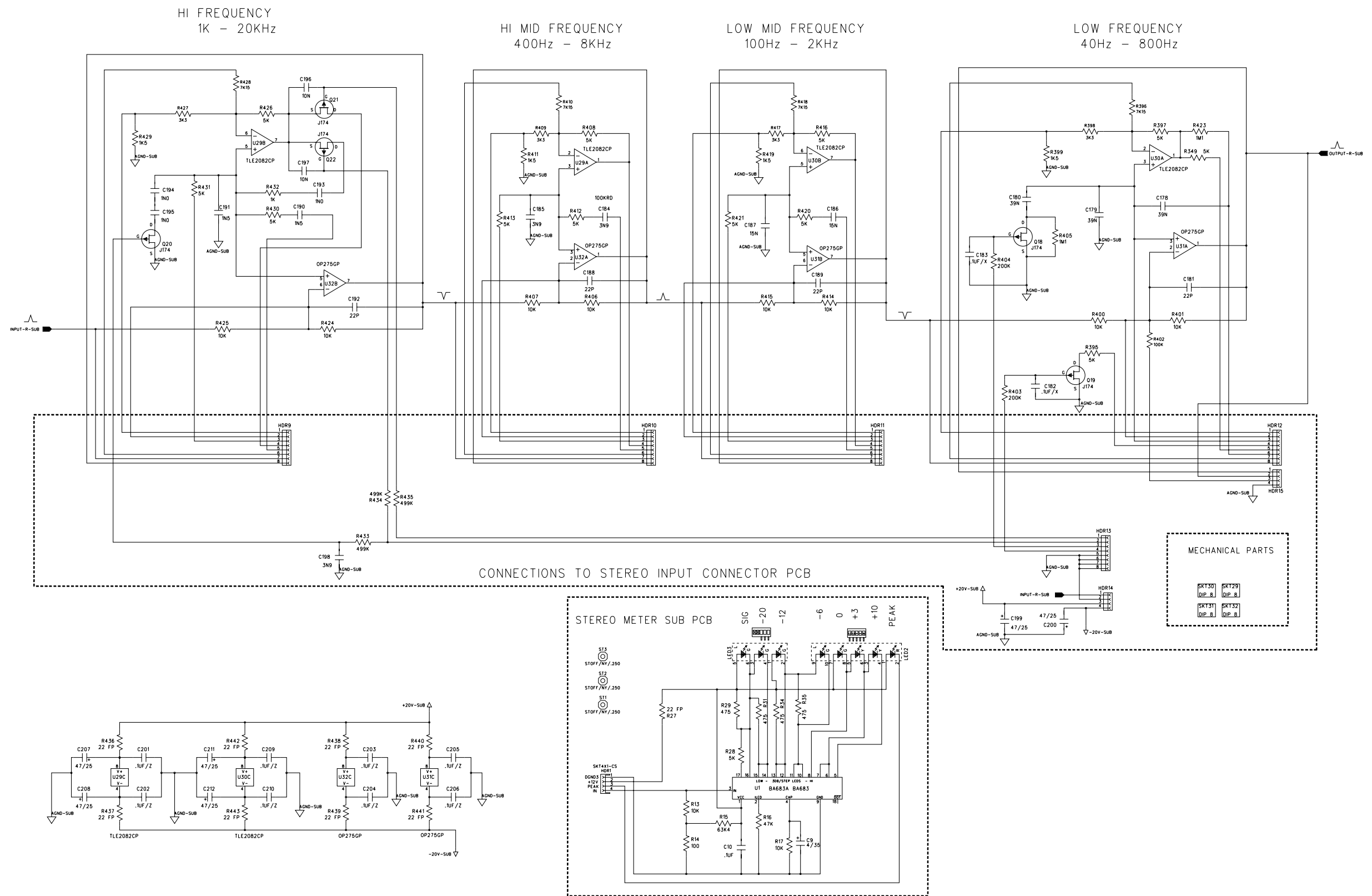

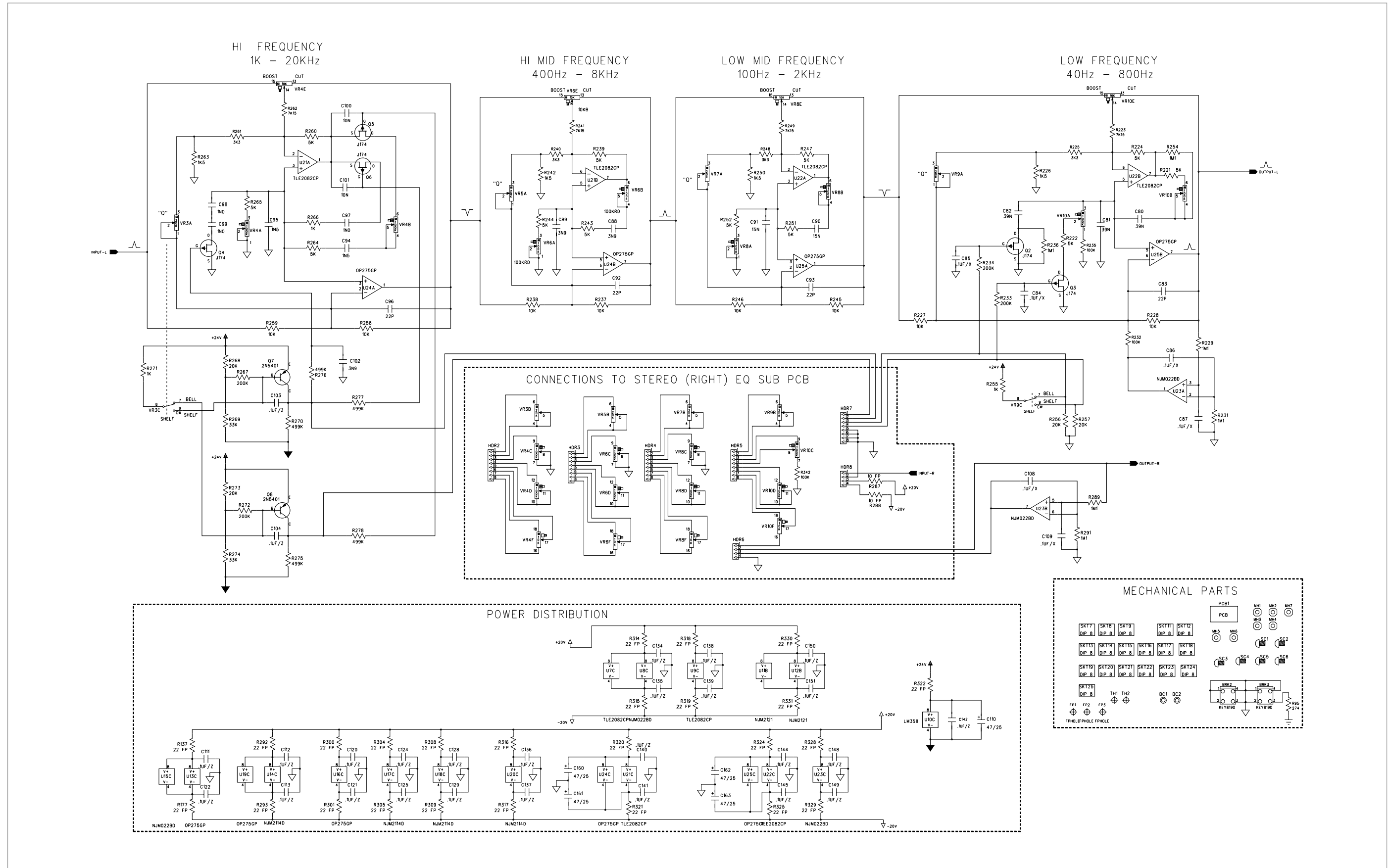

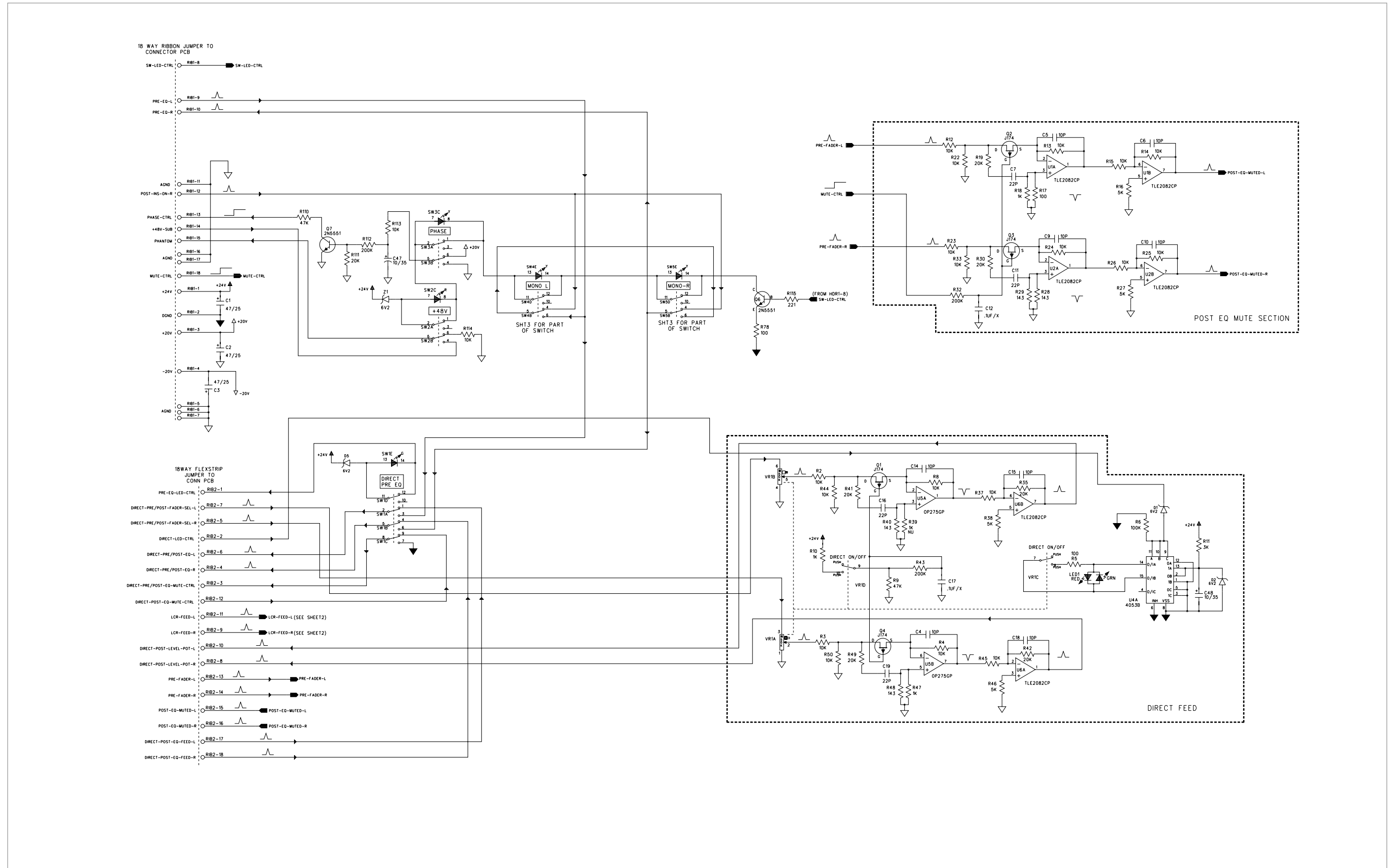

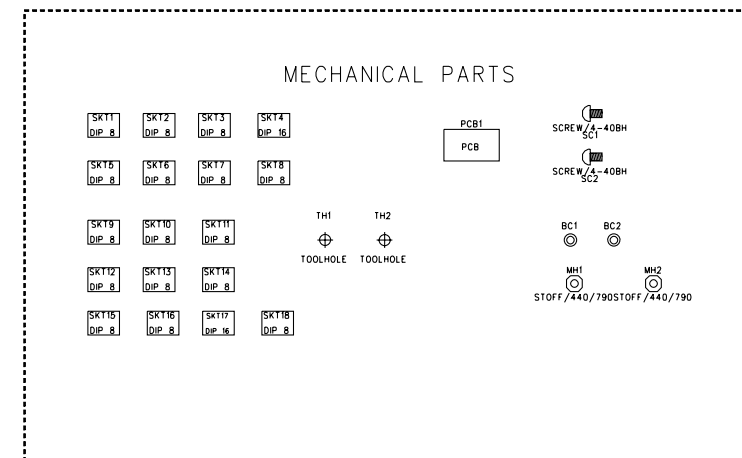
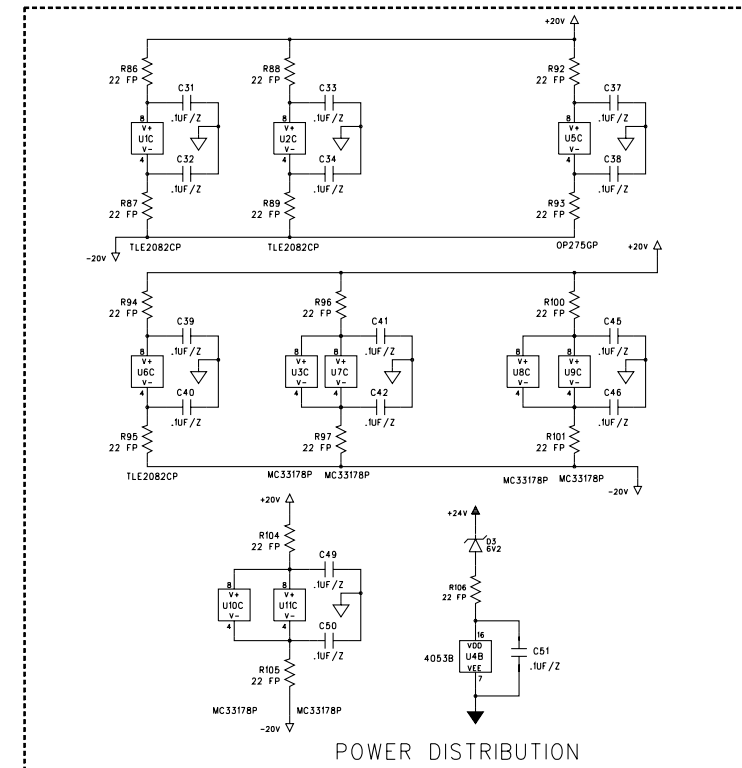
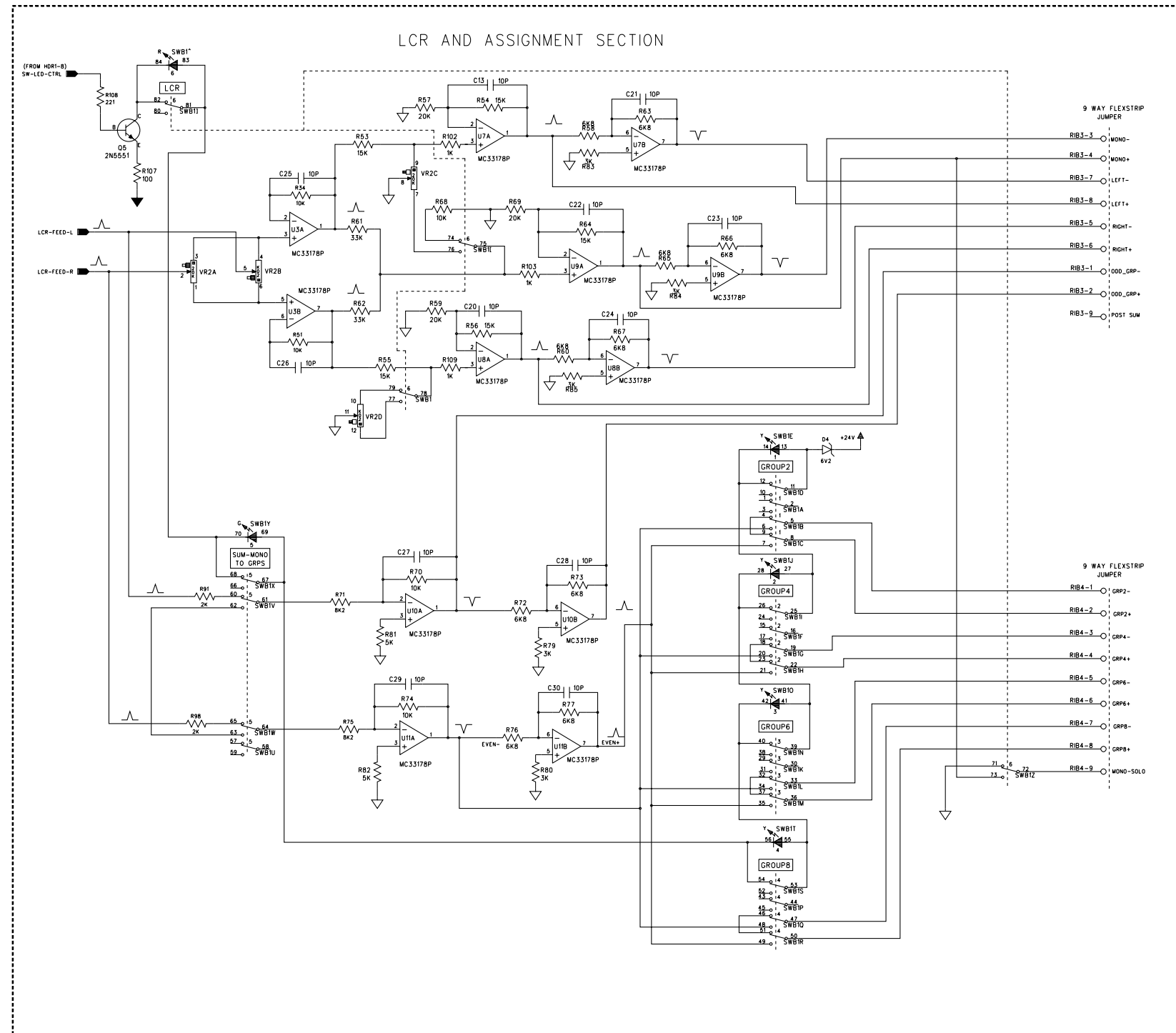

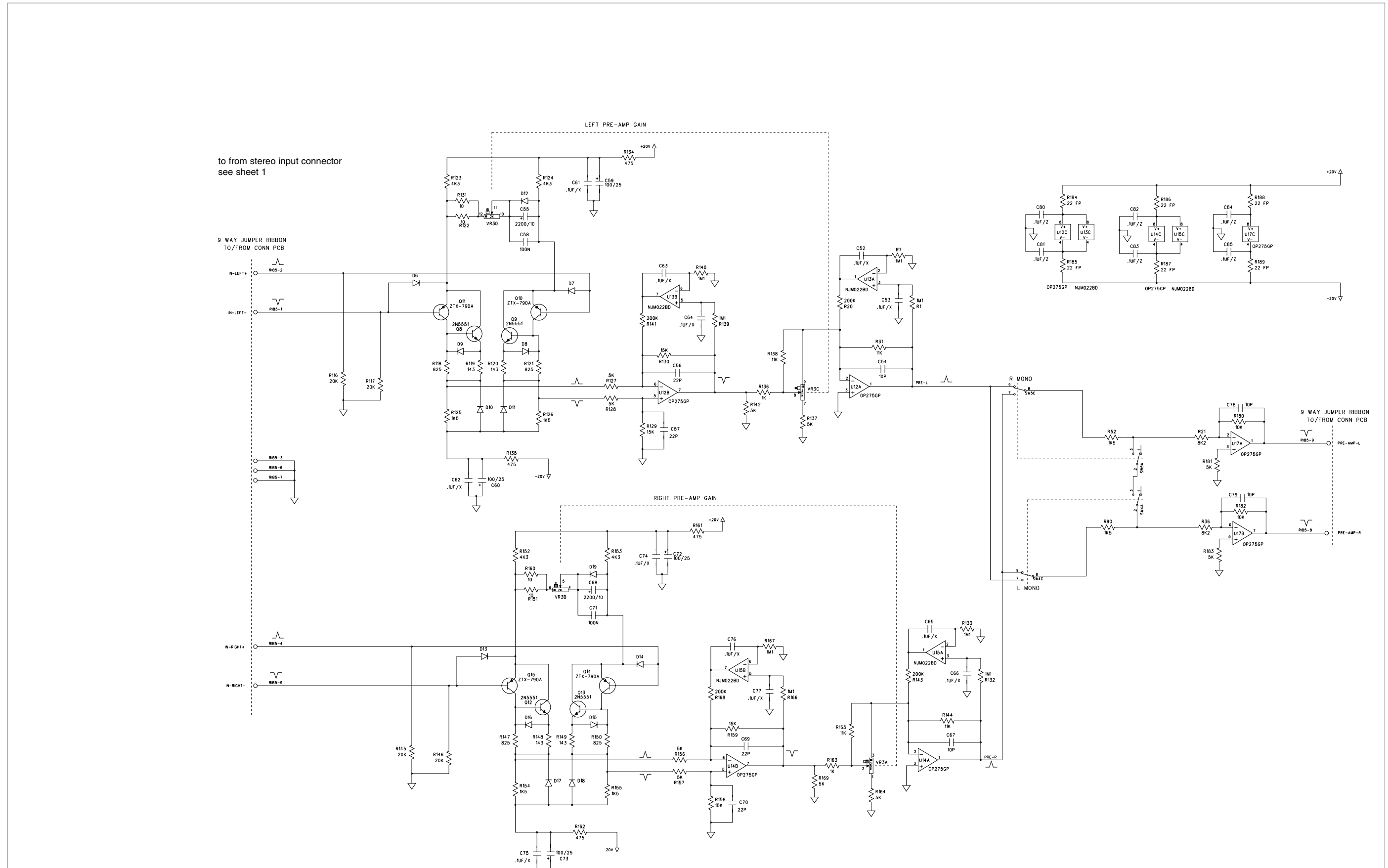

to from stereo input connector
see sheet 1

9 WAY JUMPER RIBBON
TO/FROM CONN PCB

9 WAY JUMPER RIBBON
TO/FROM CONN PCB

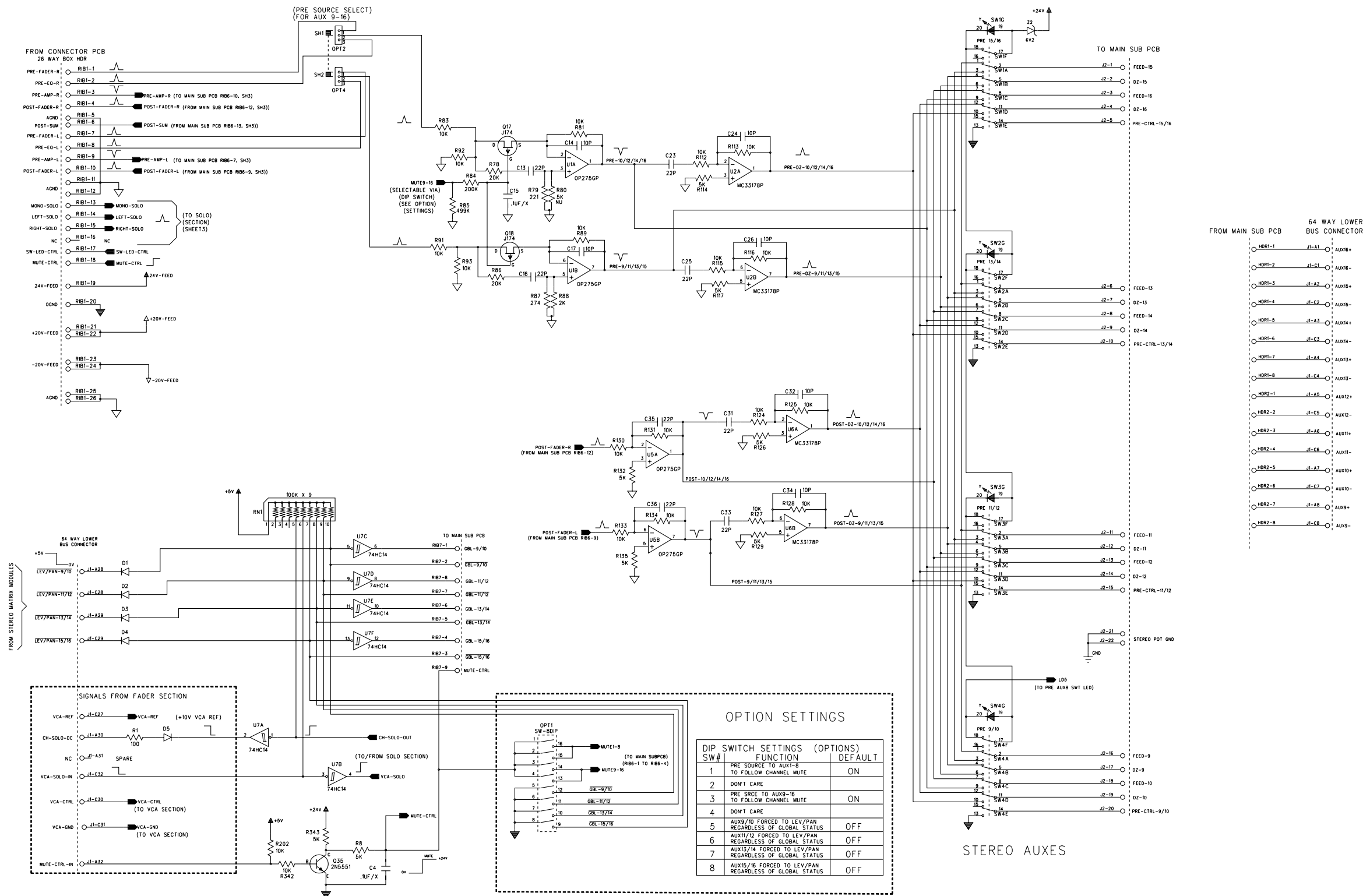

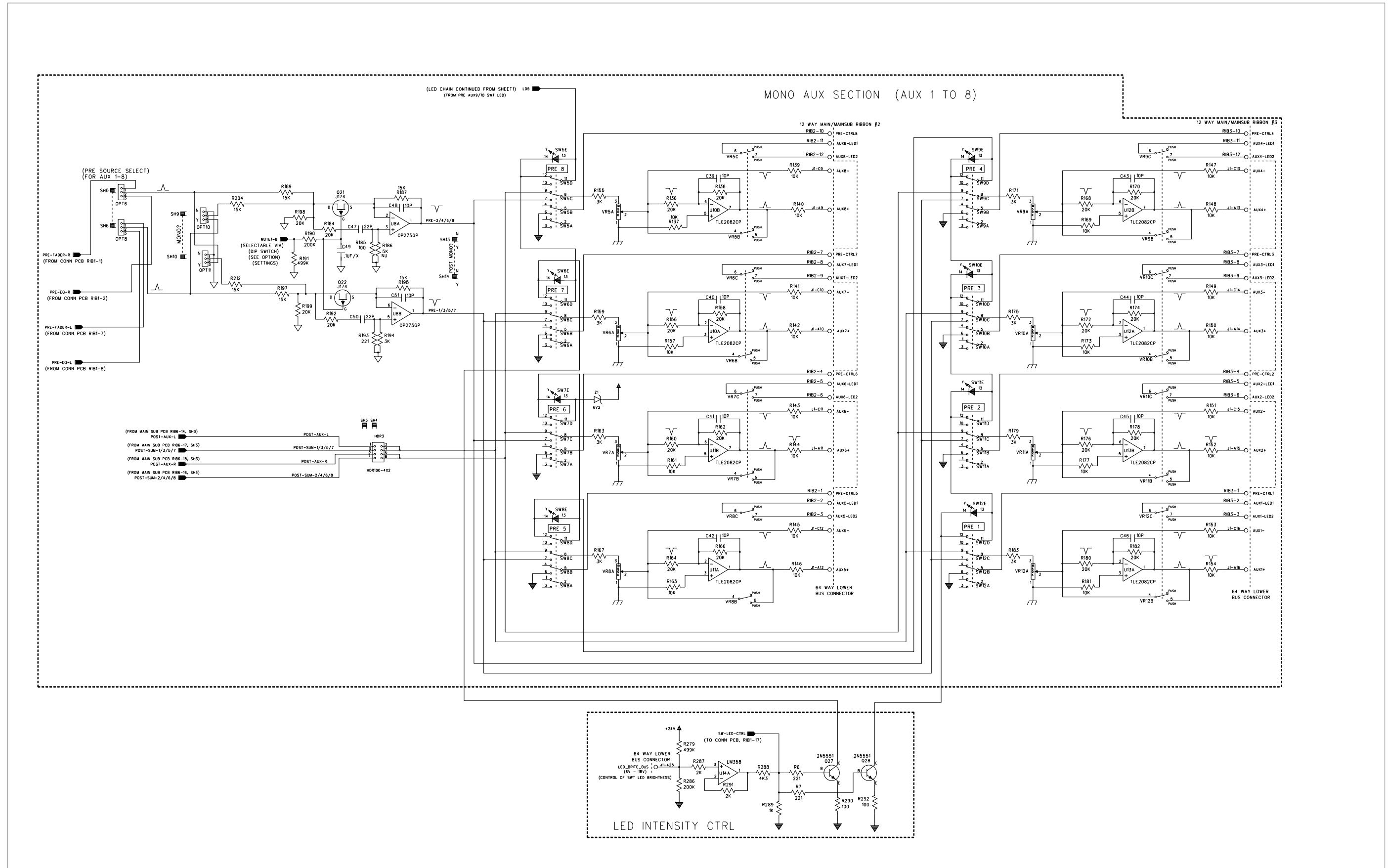

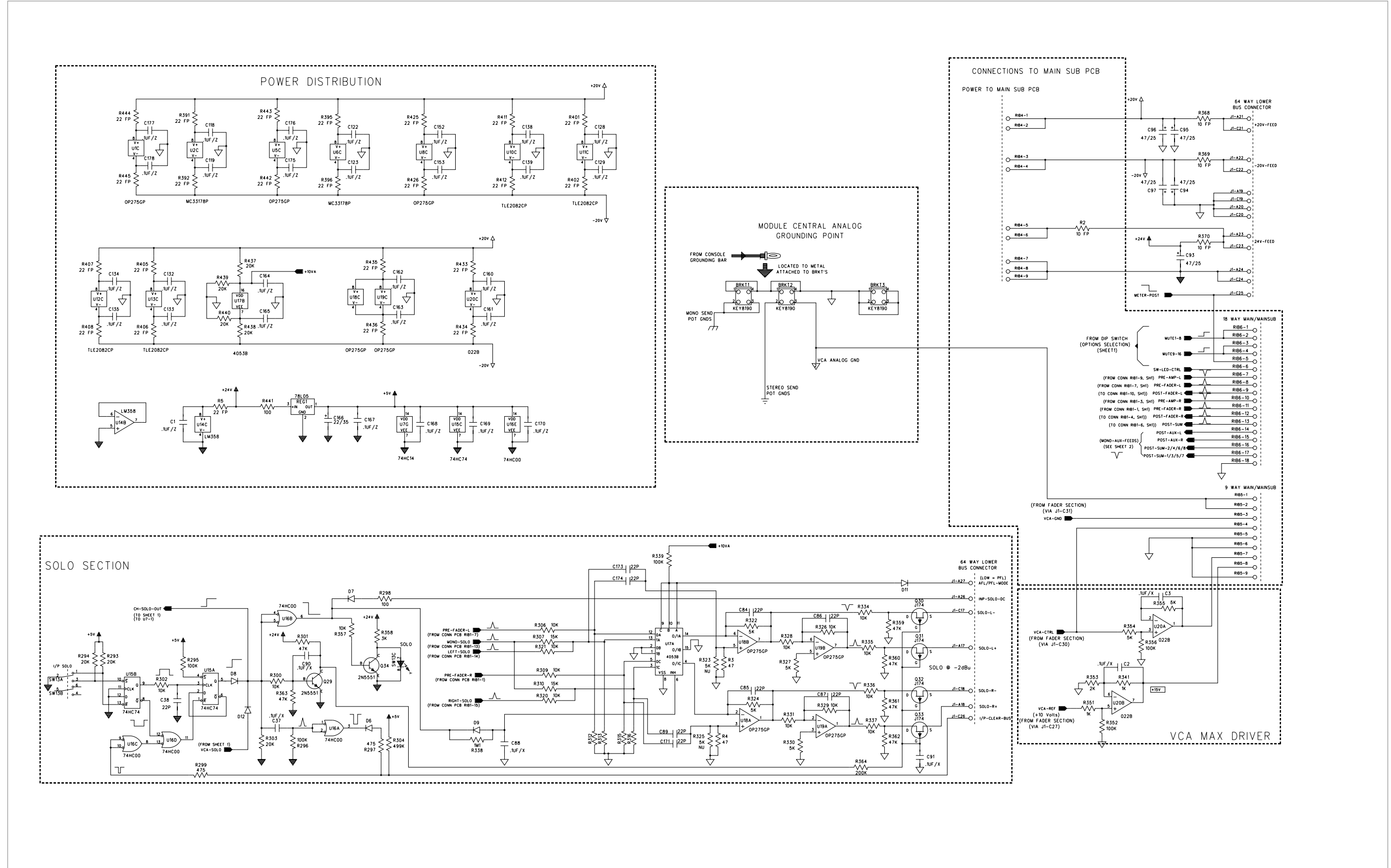

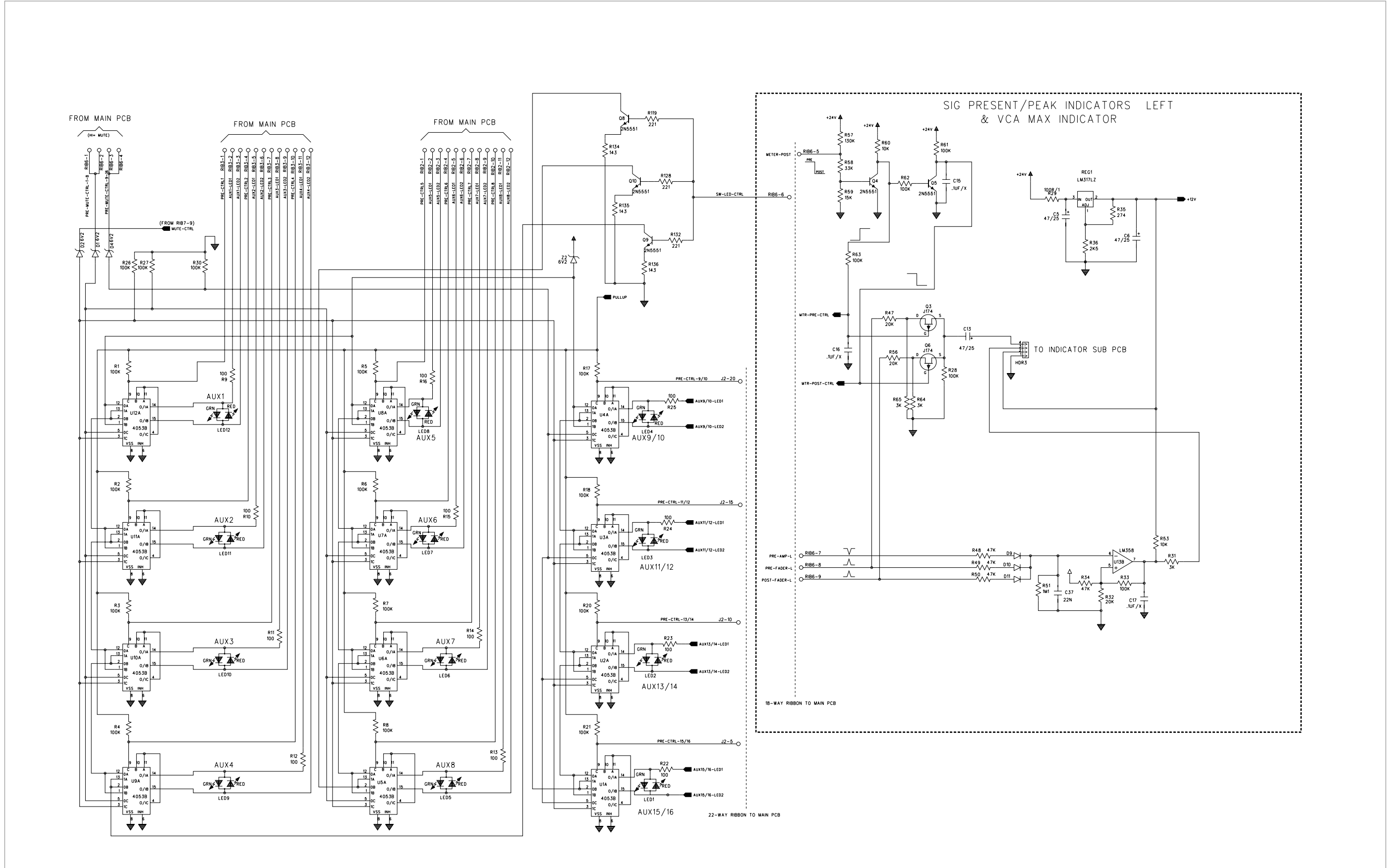

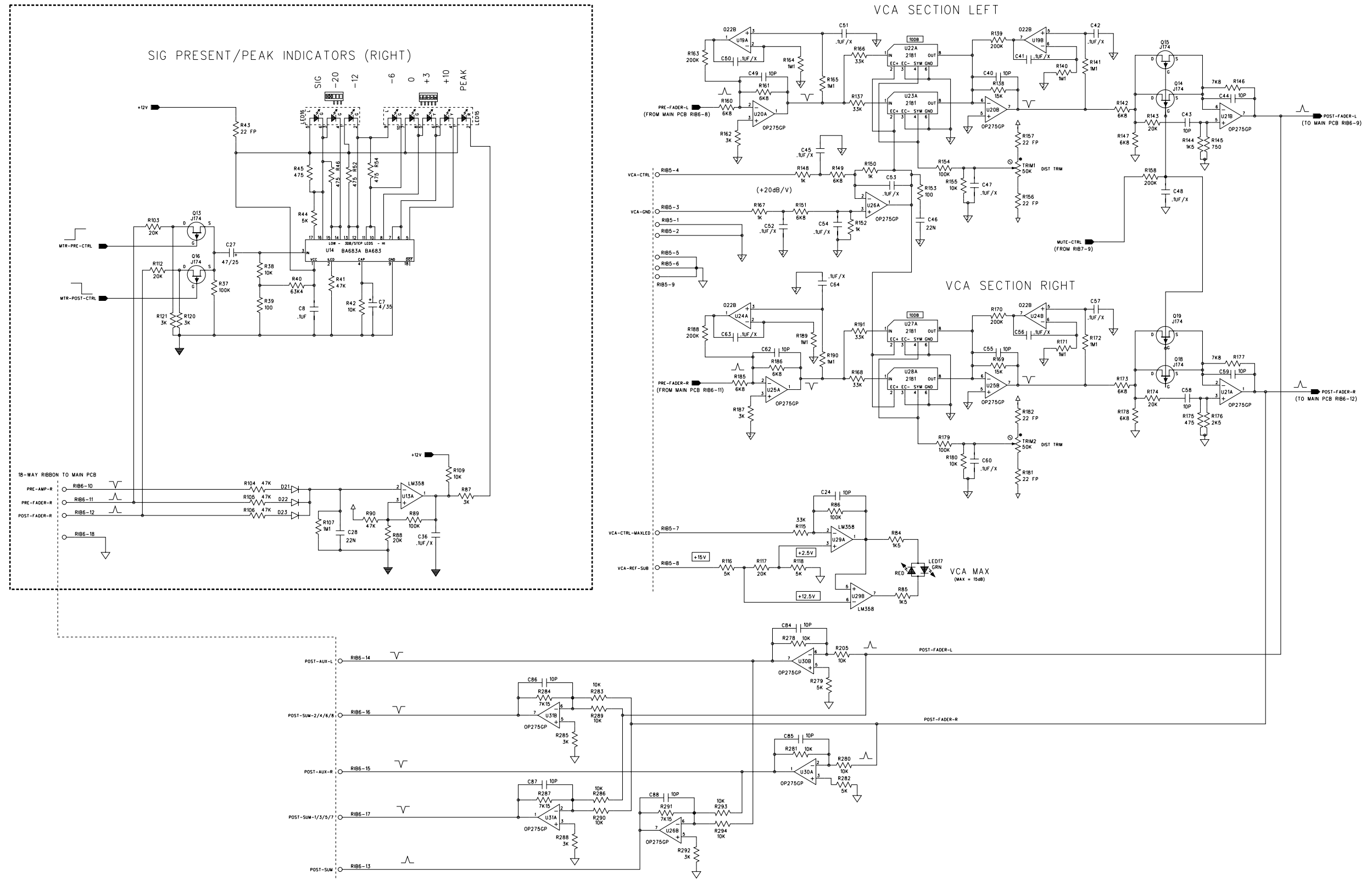

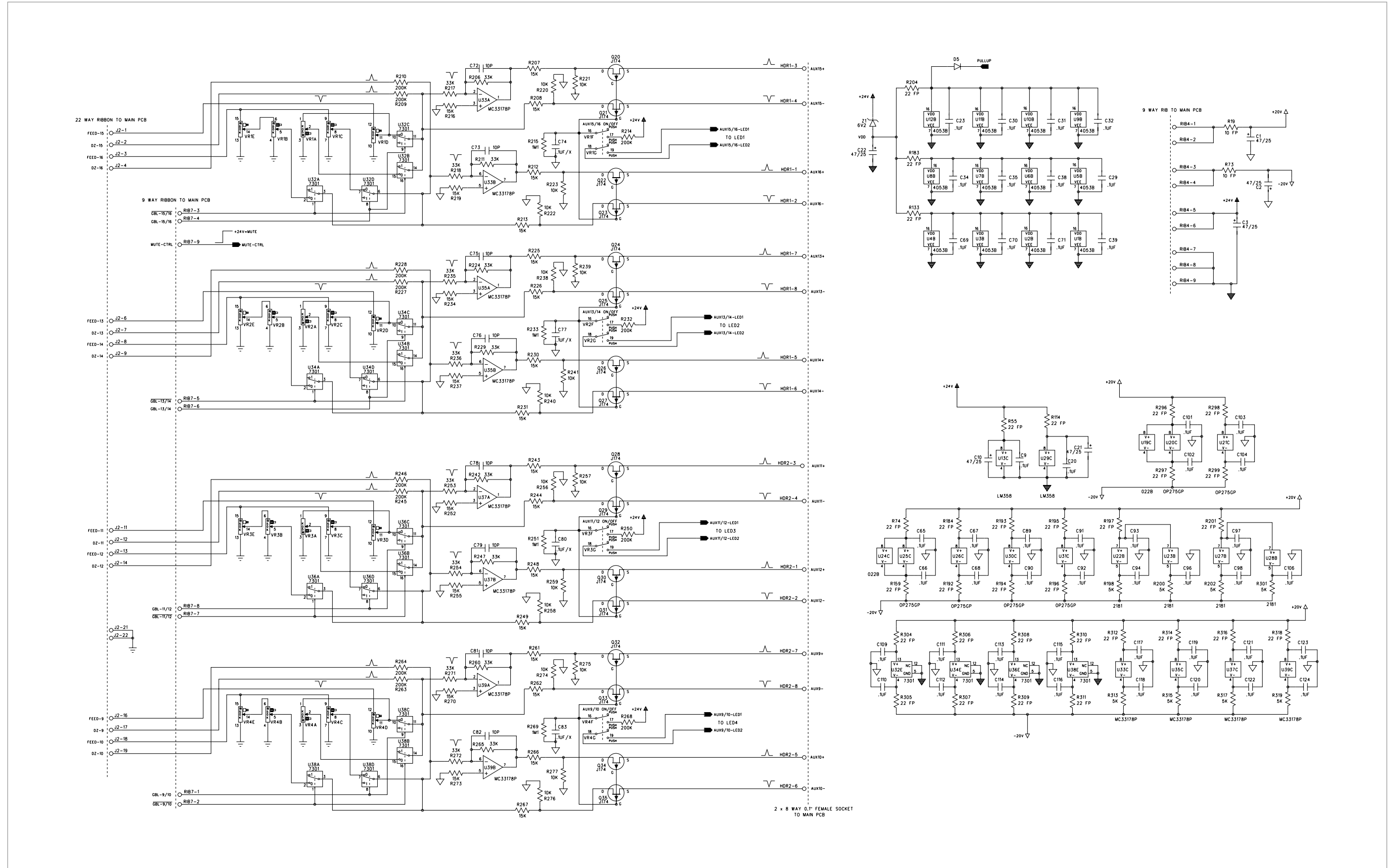

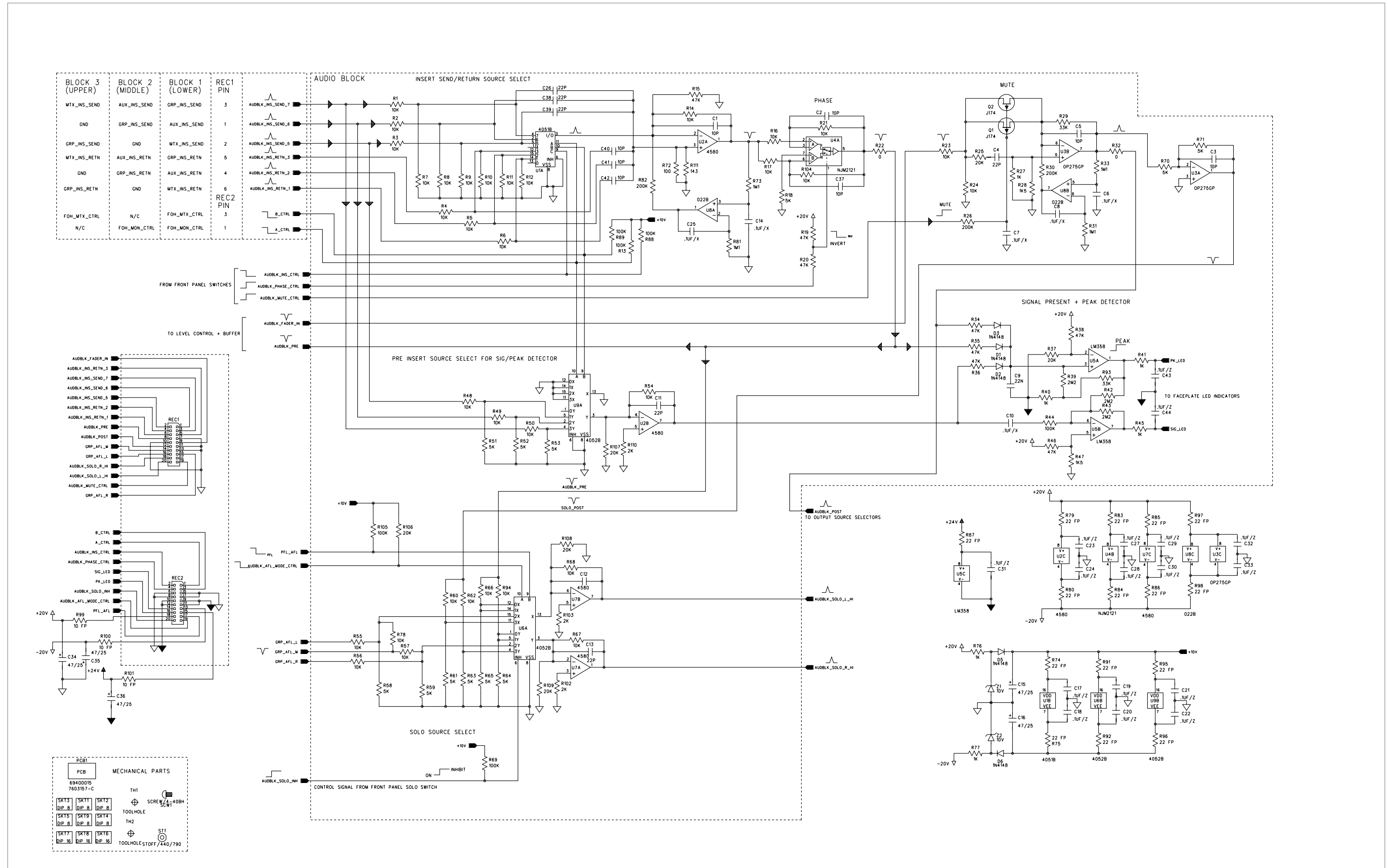

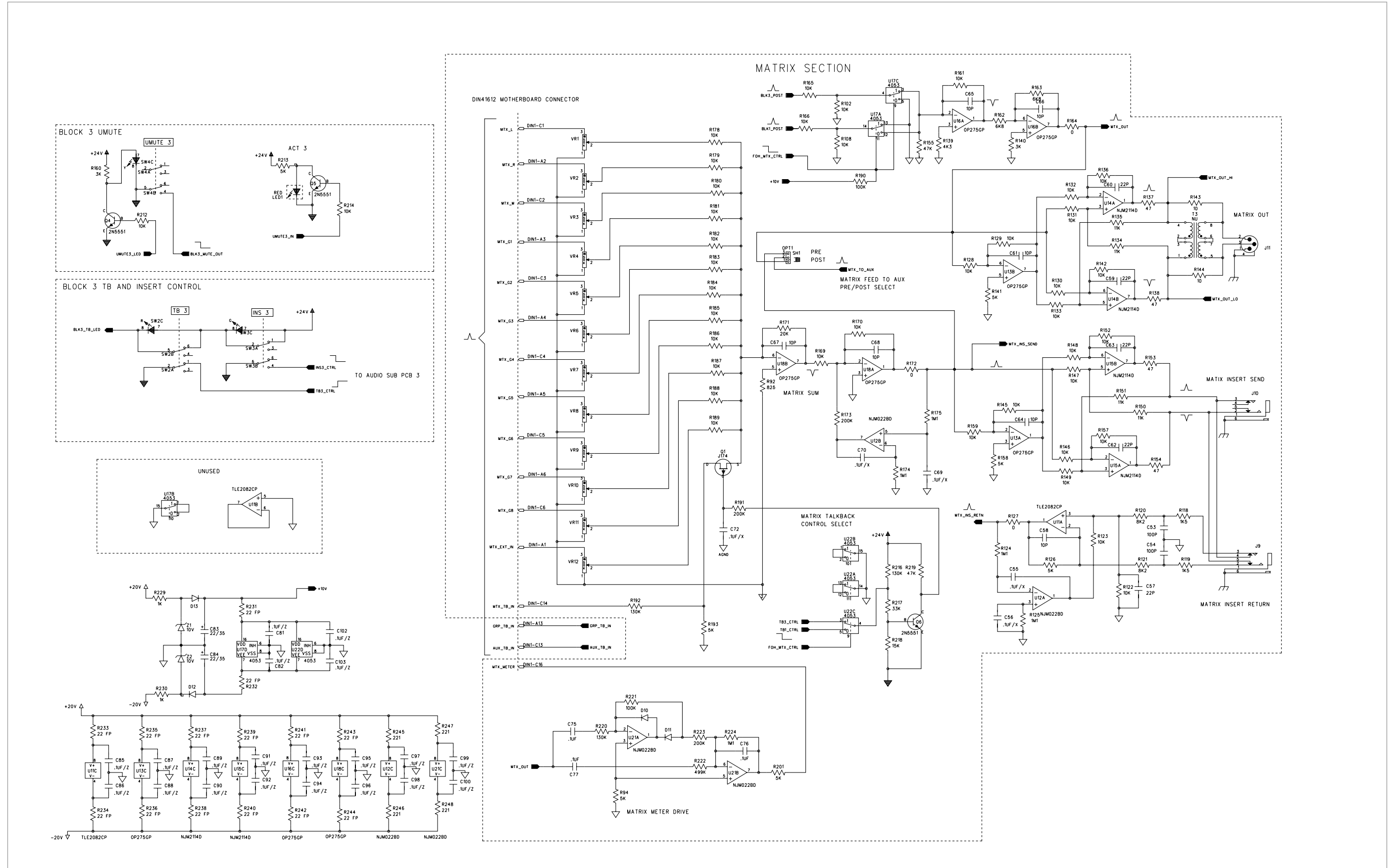

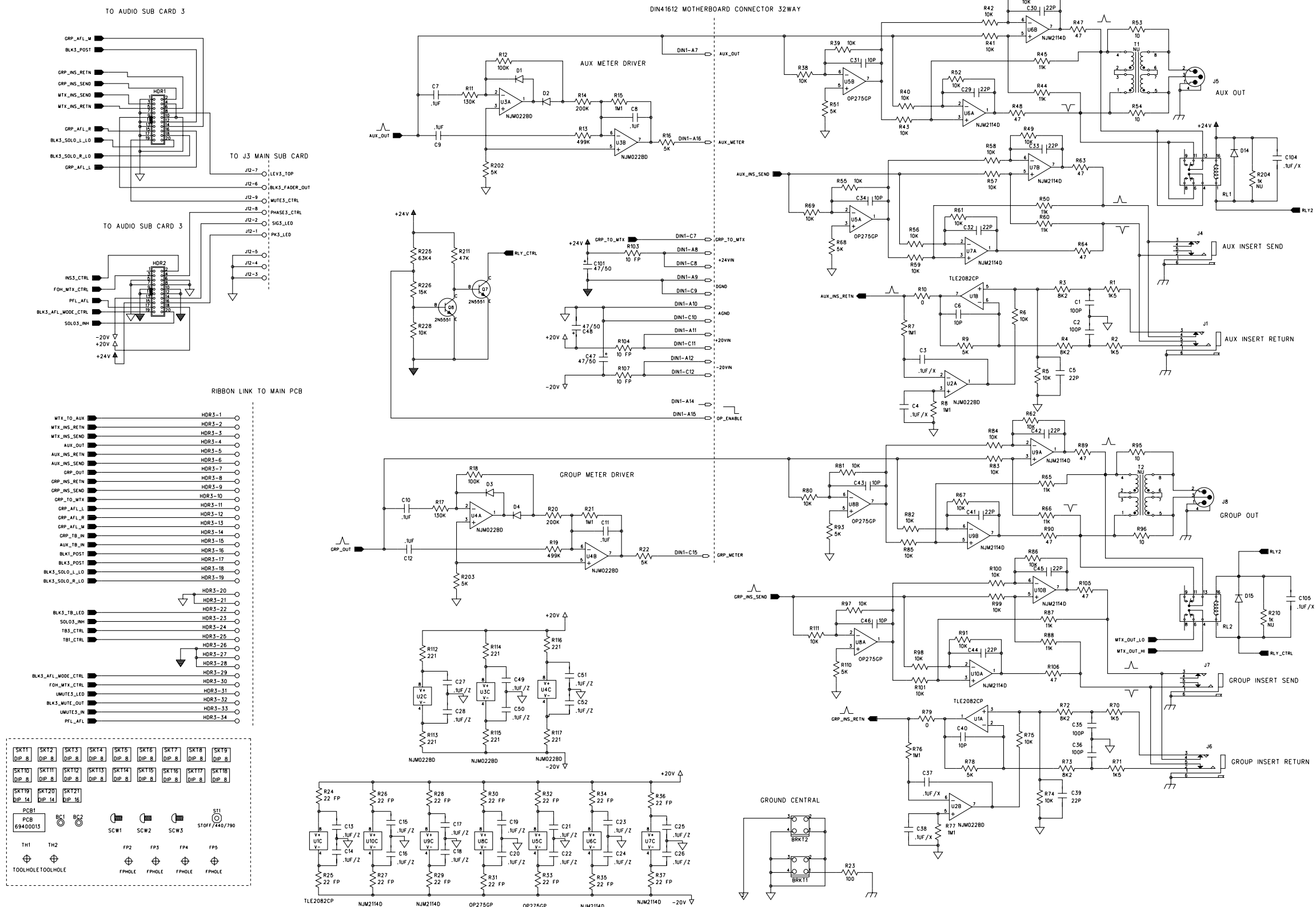

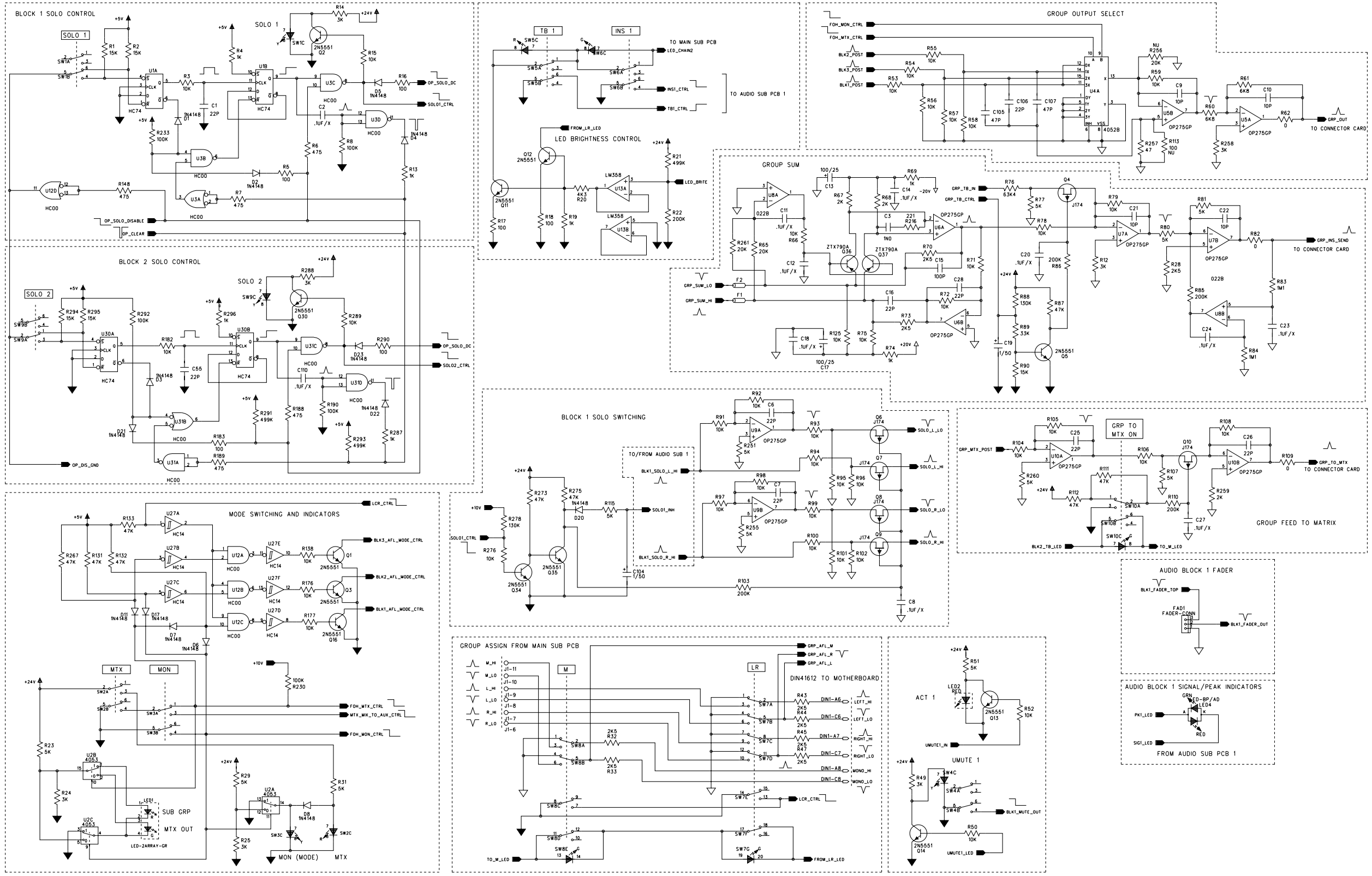

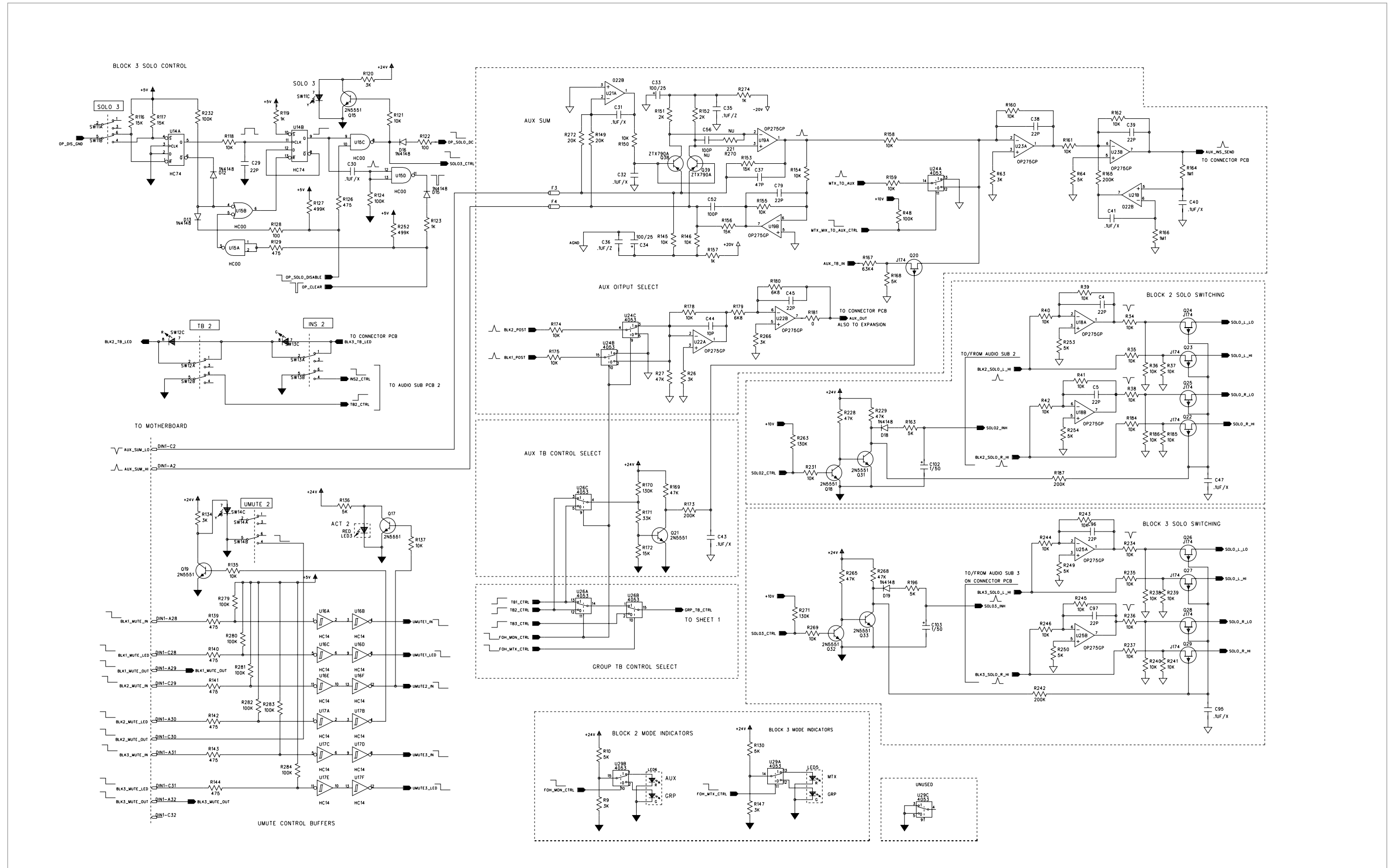

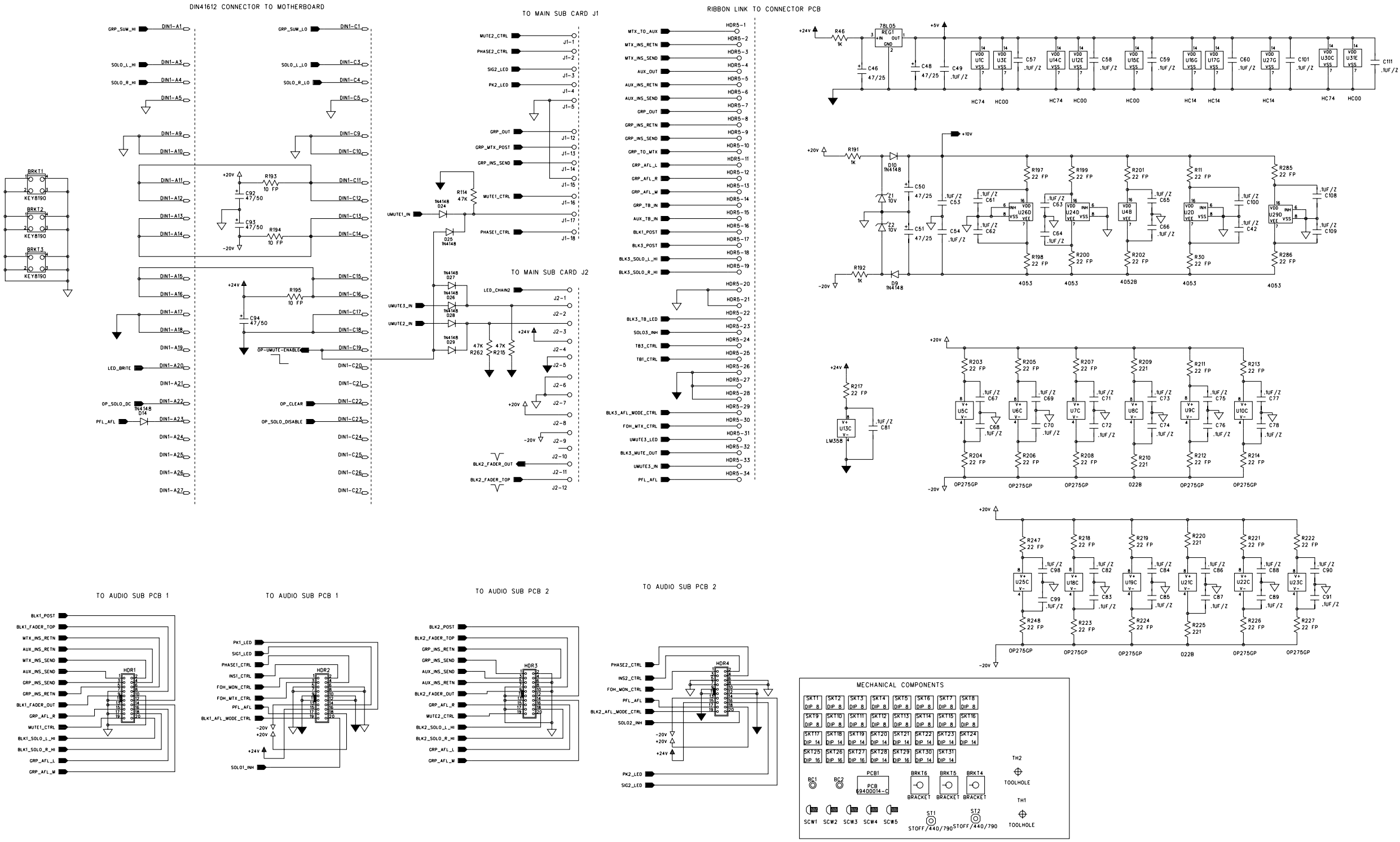

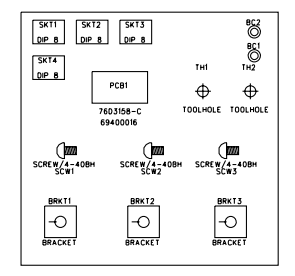
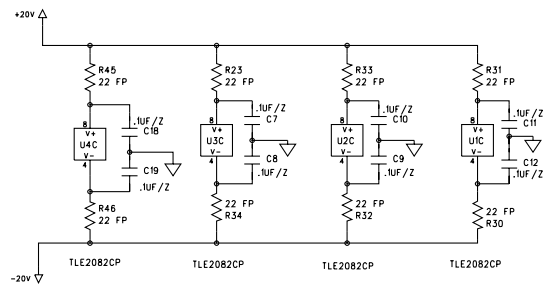
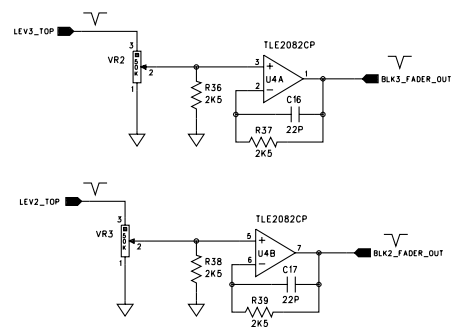
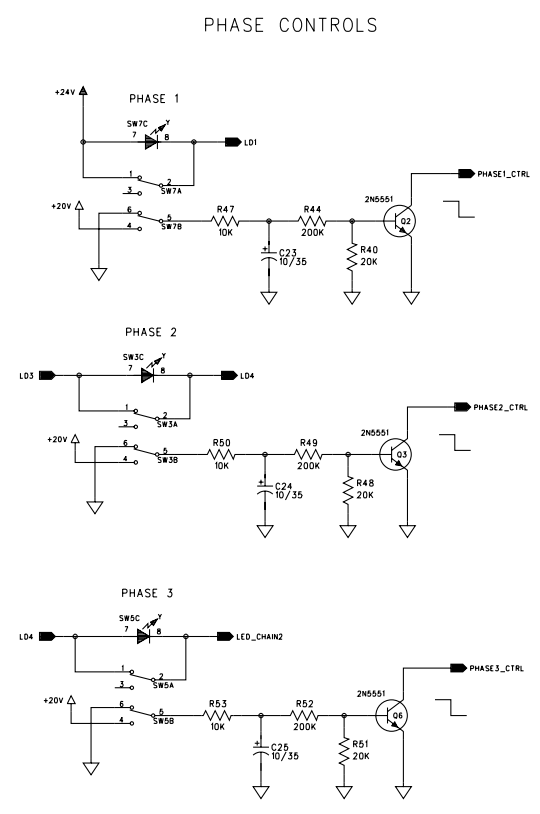
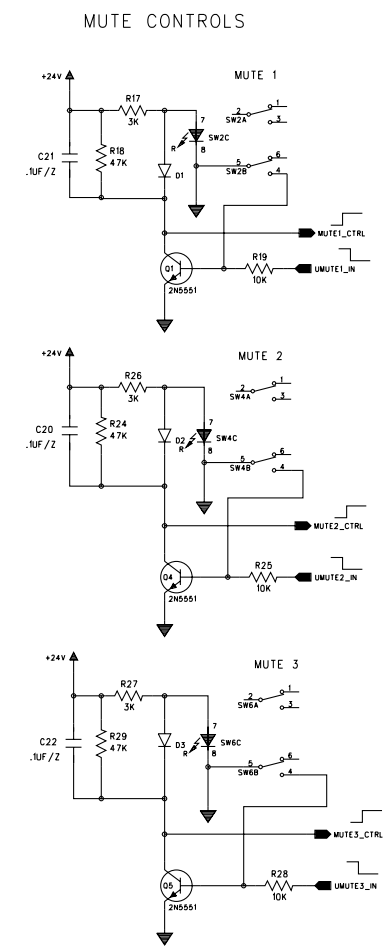
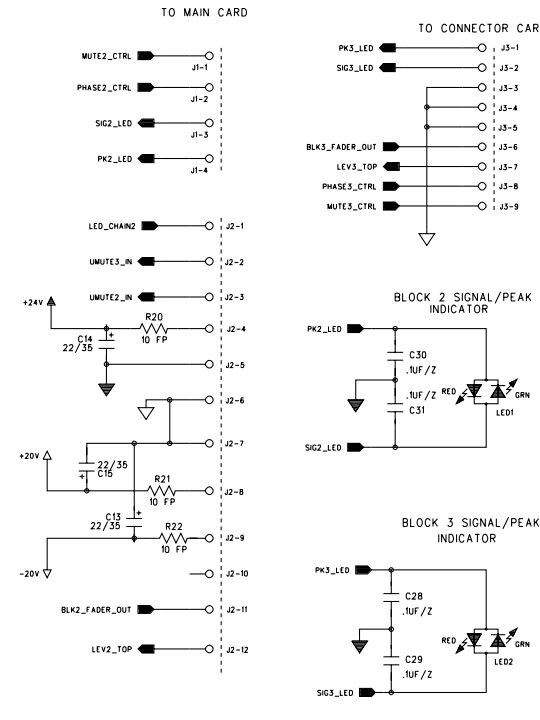
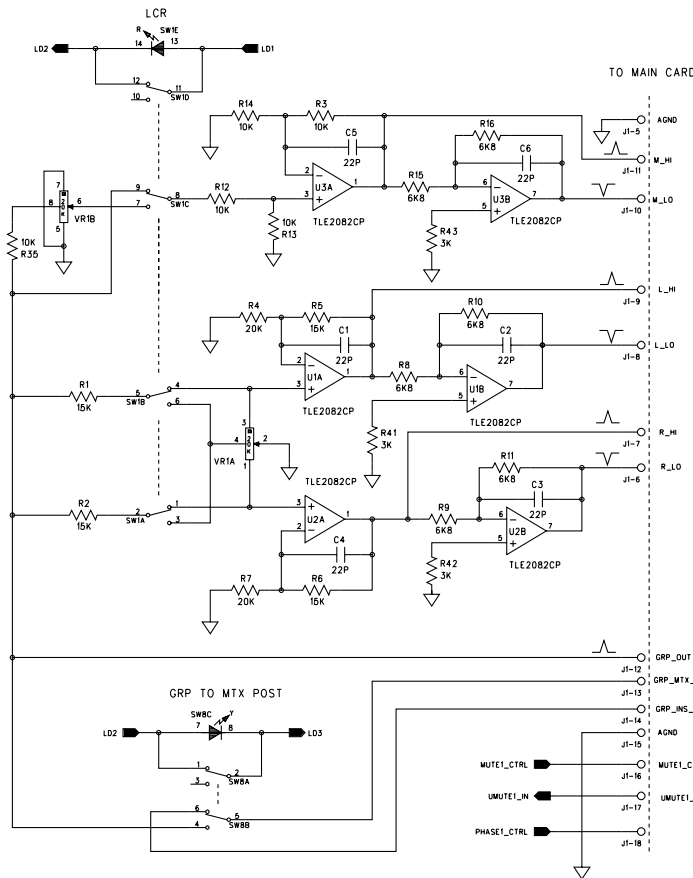

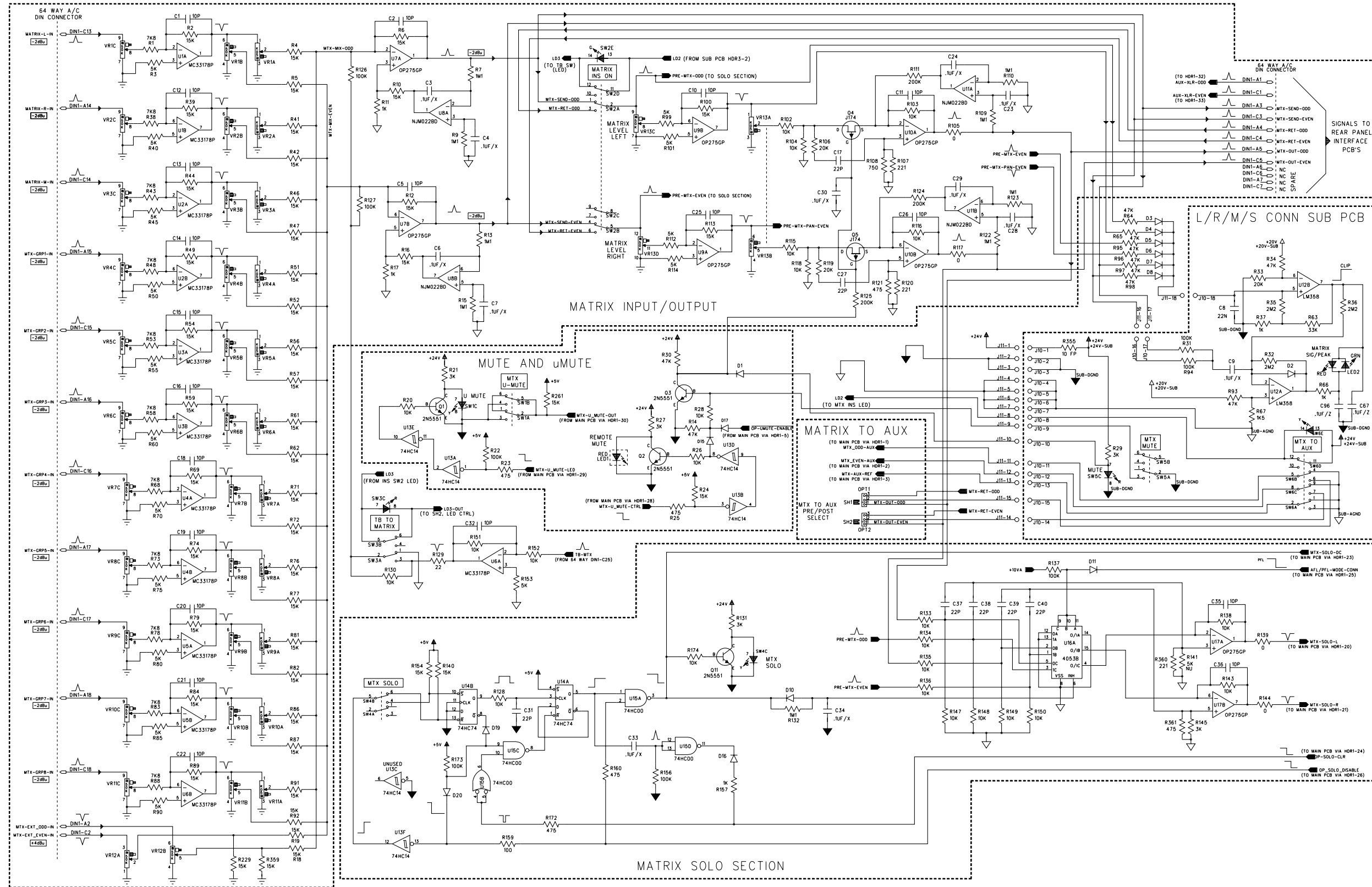

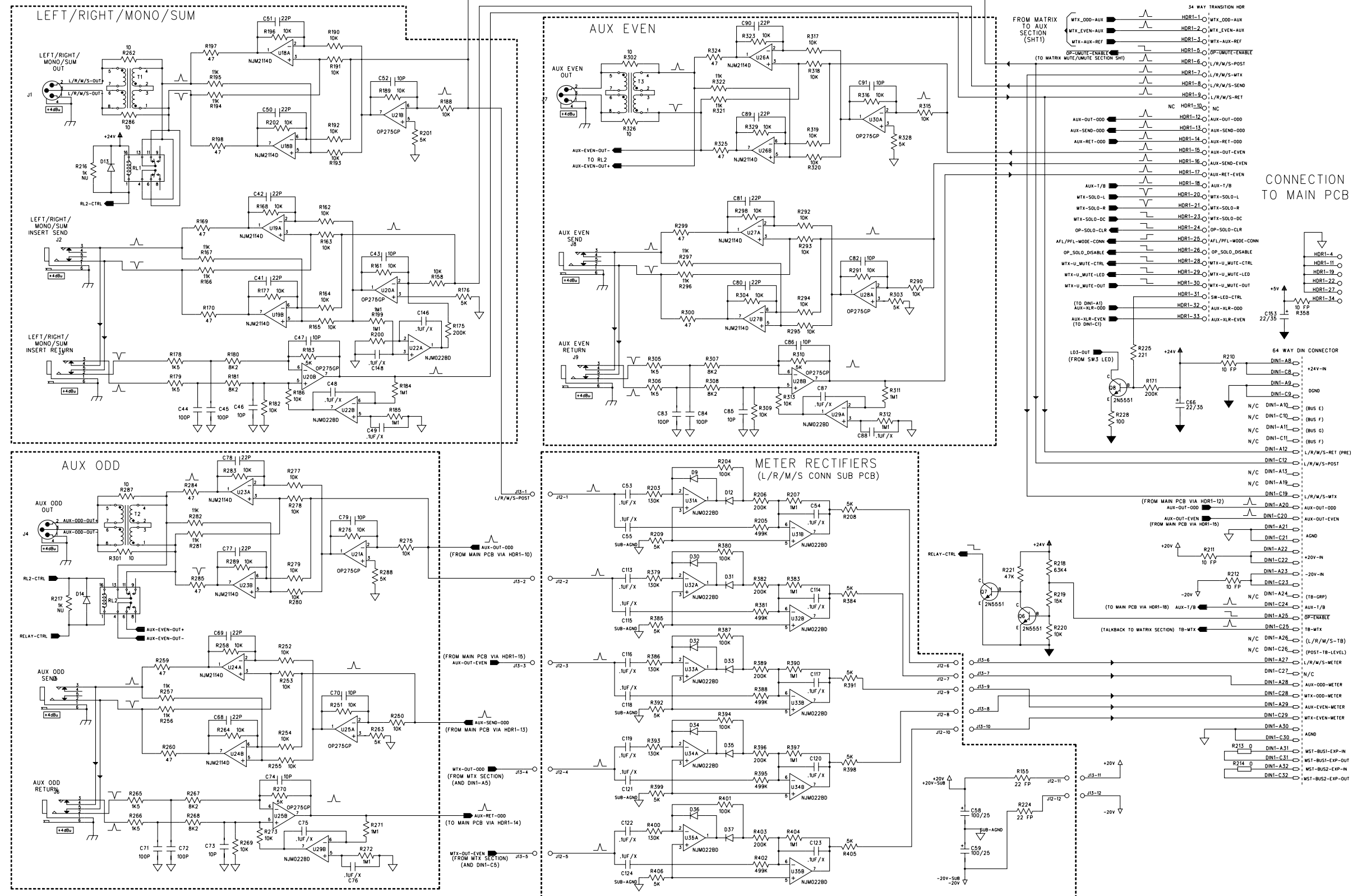

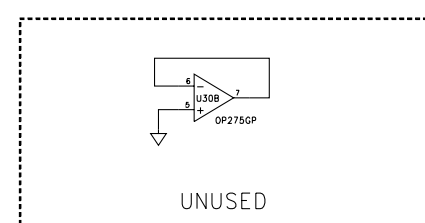
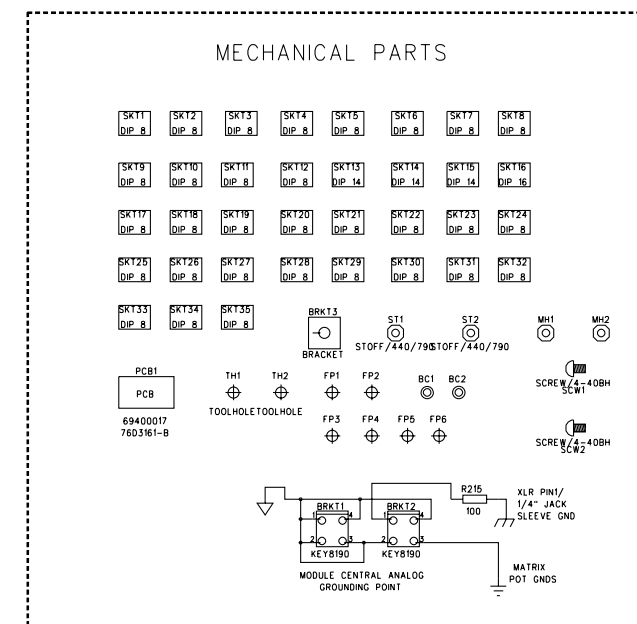
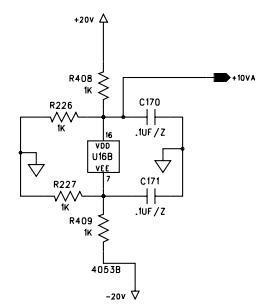
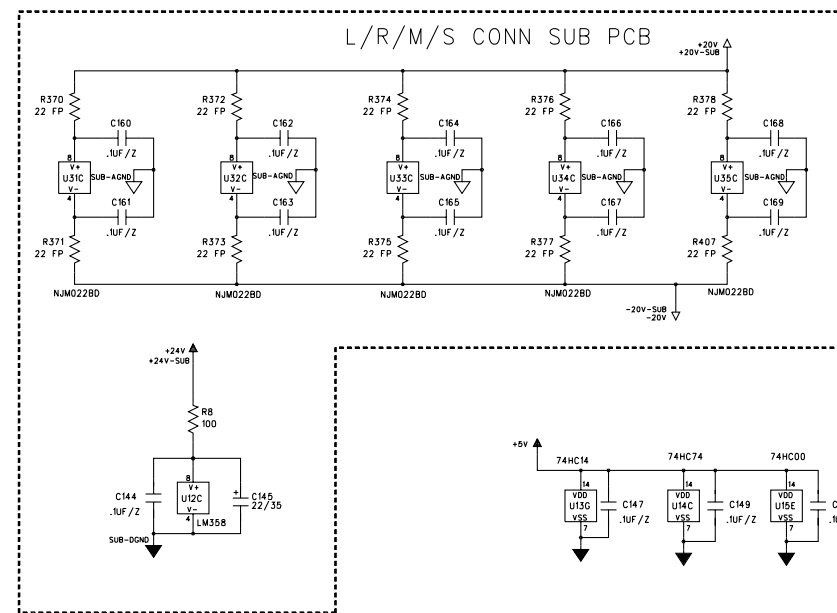
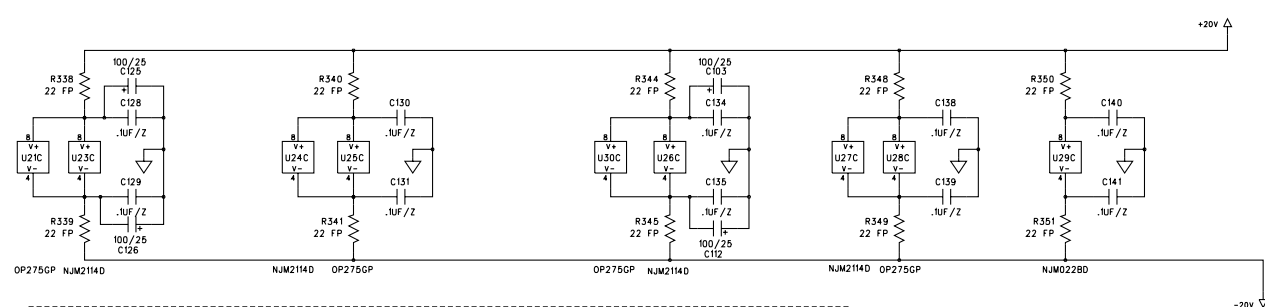
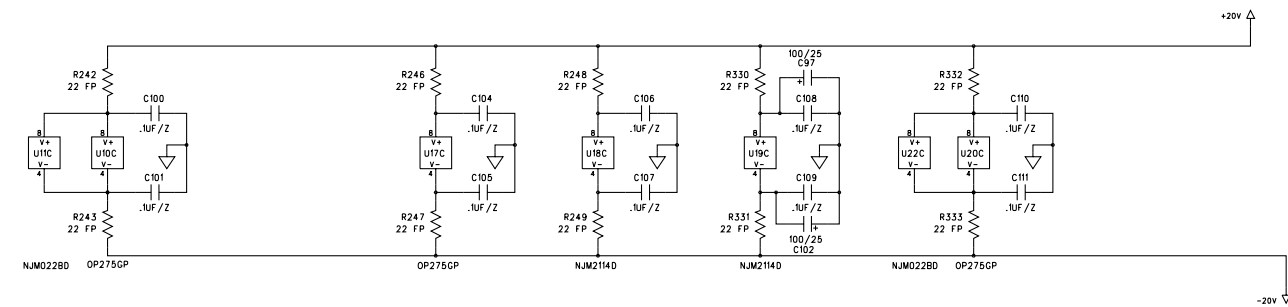
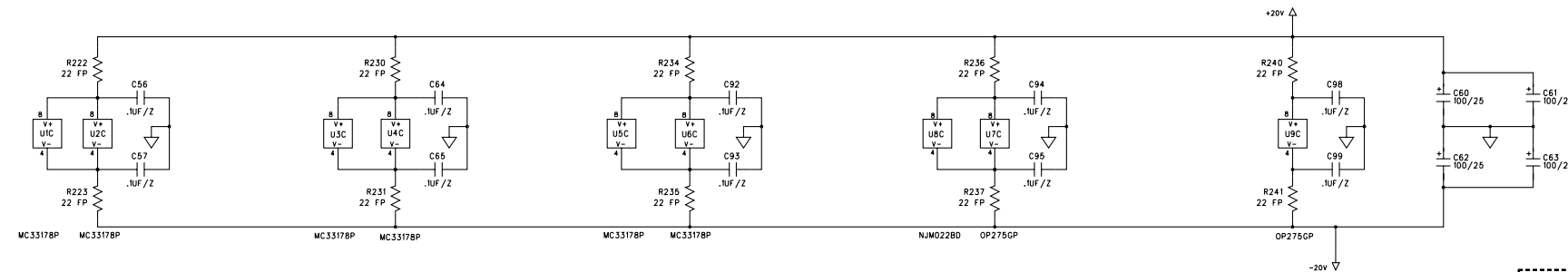

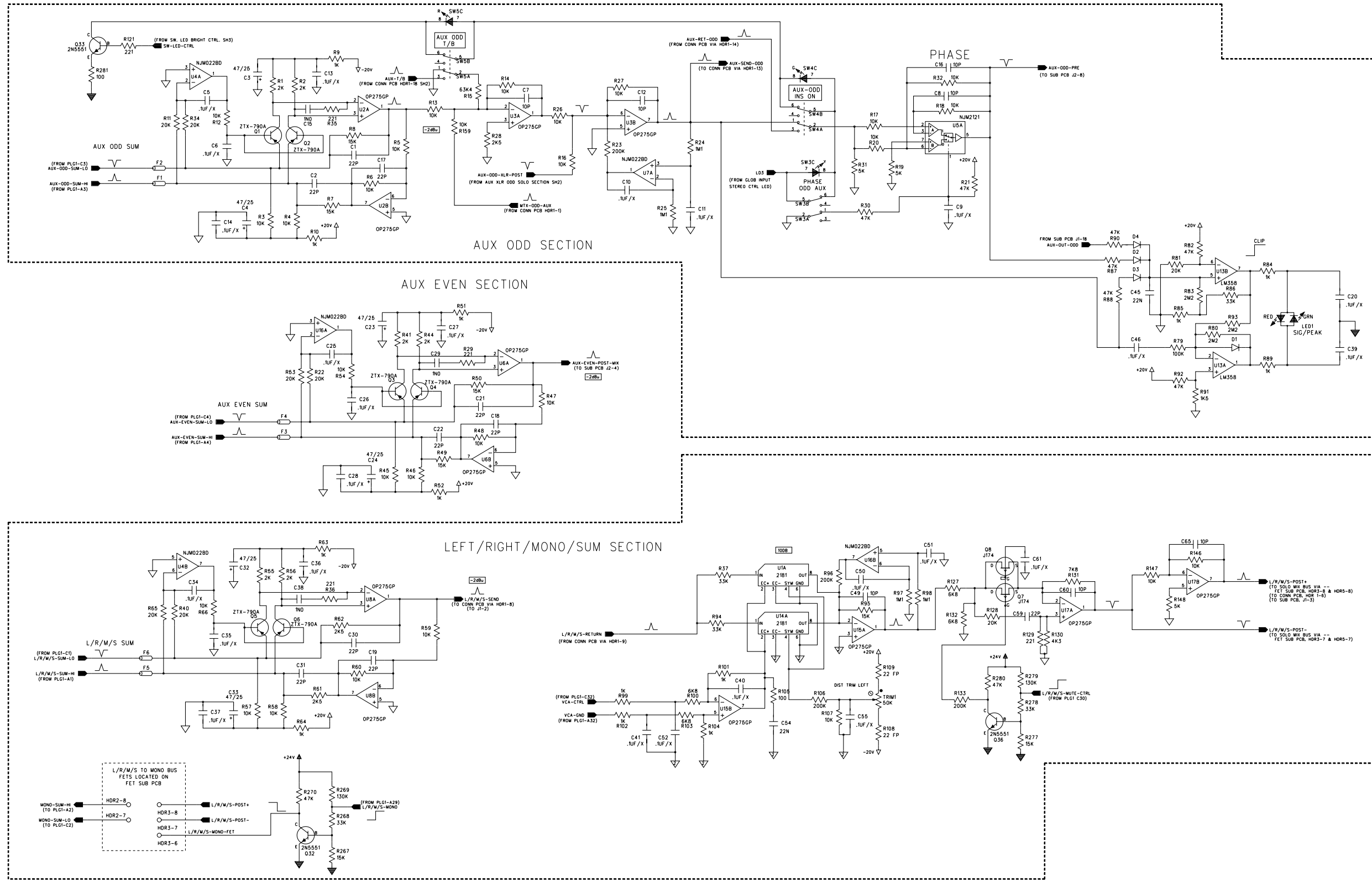

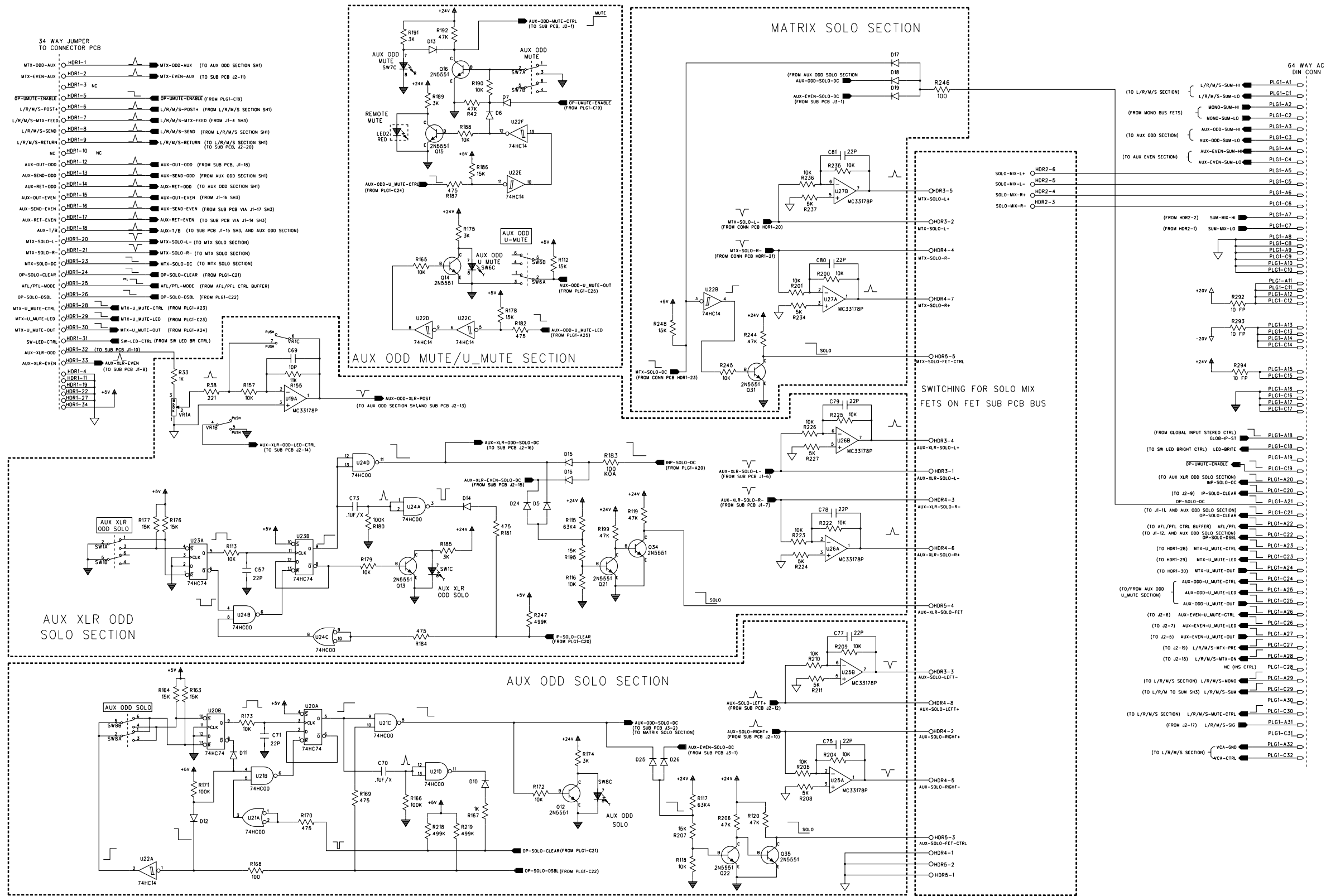

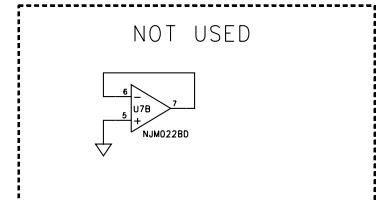
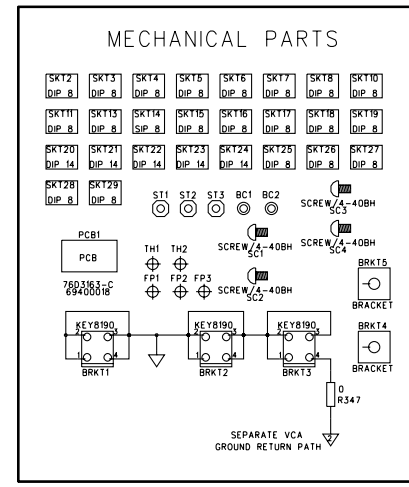
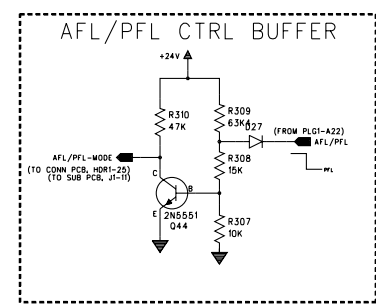
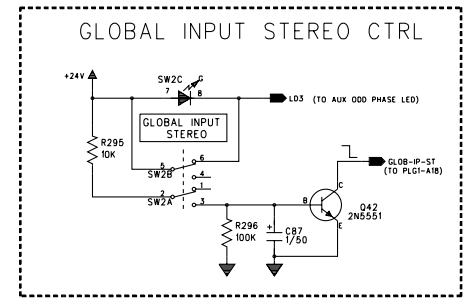
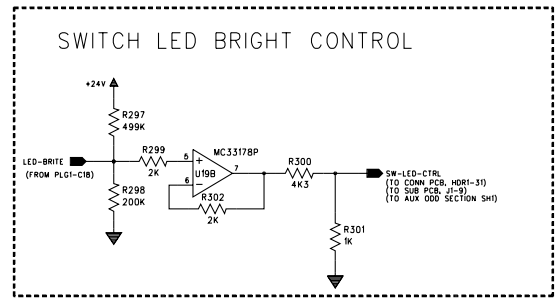
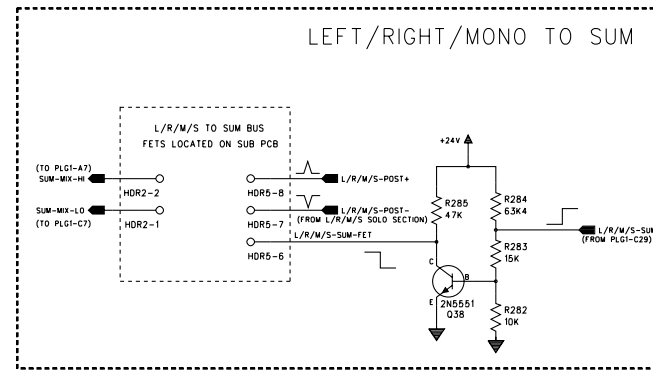
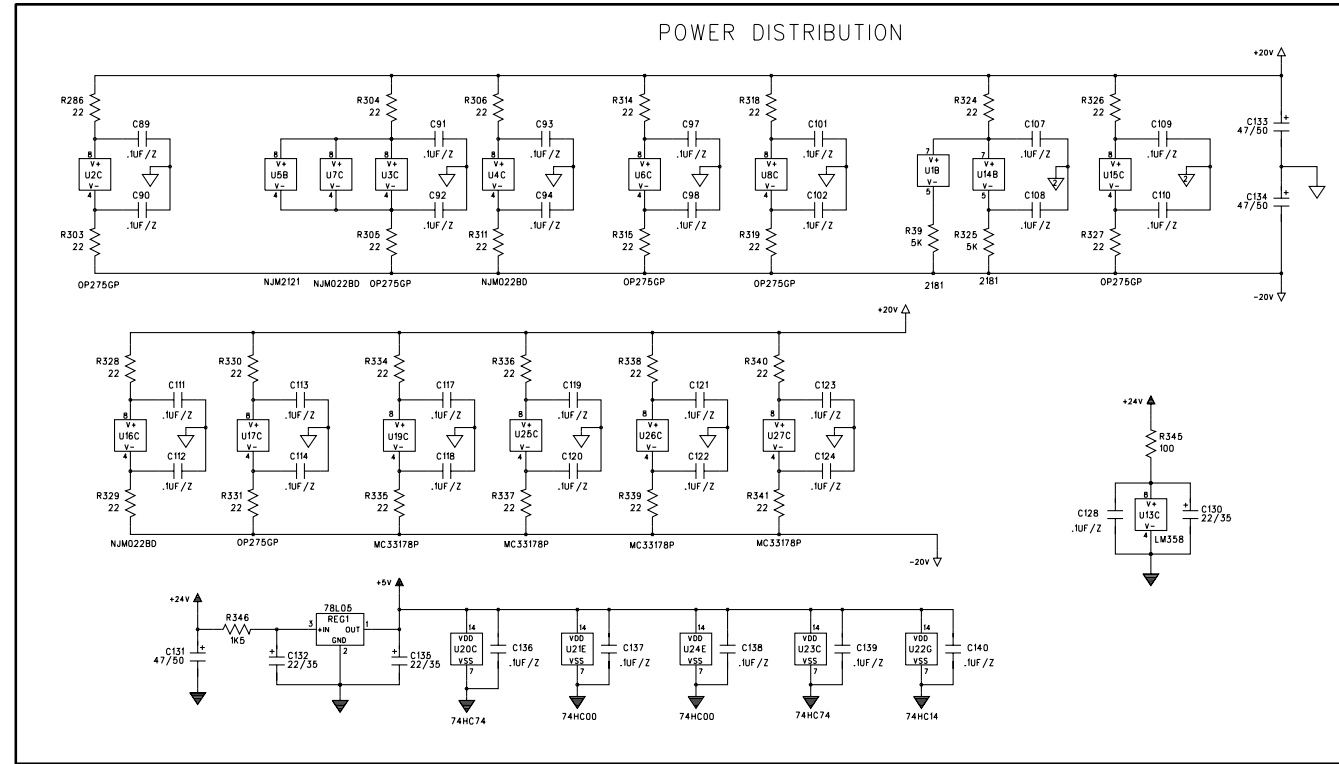
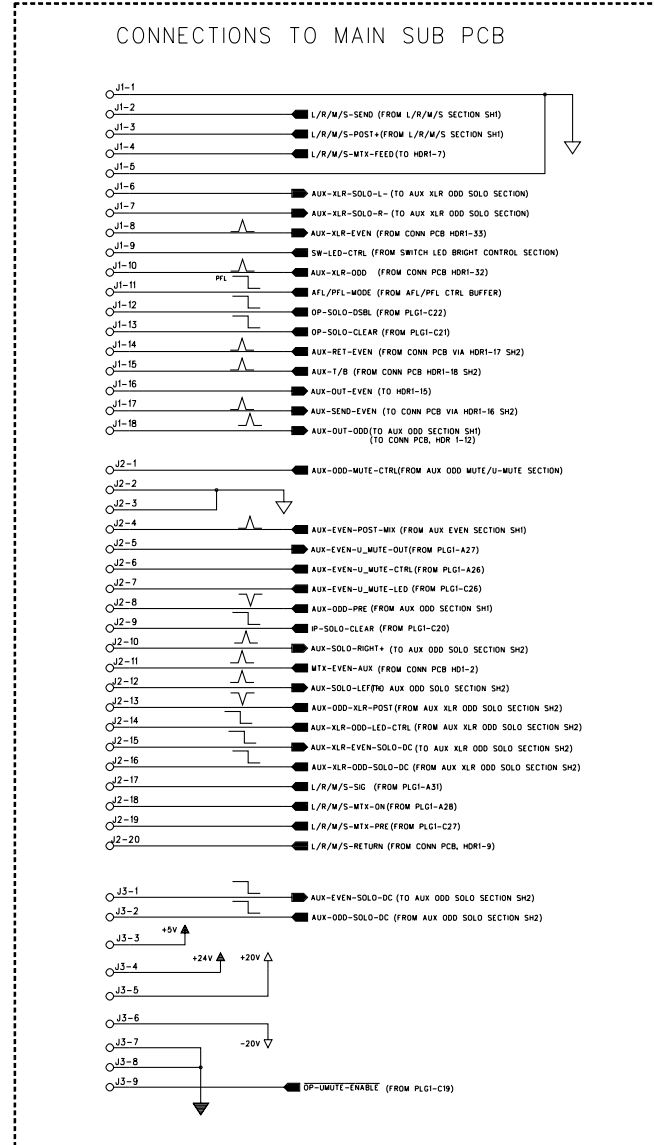

MAIN PCB CONNECTIONS

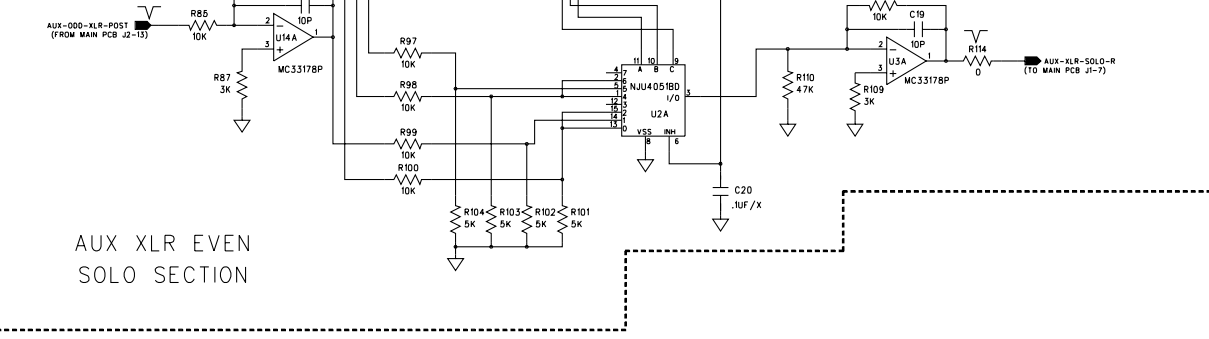
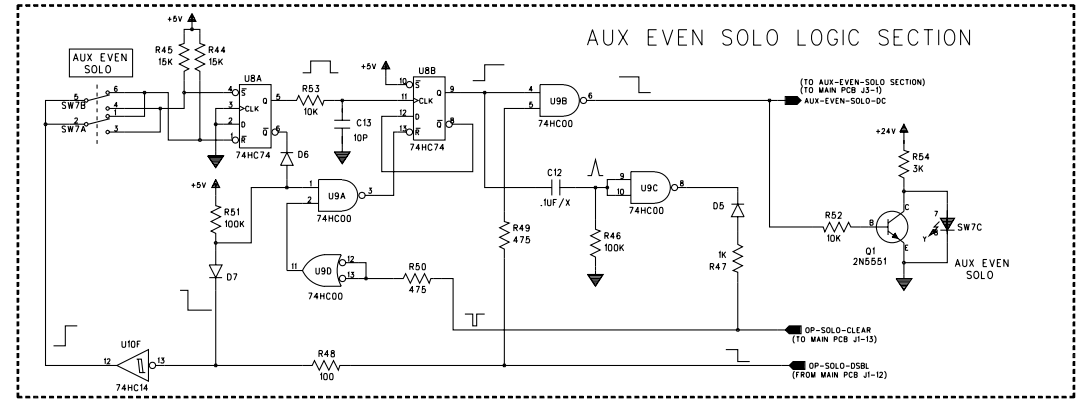
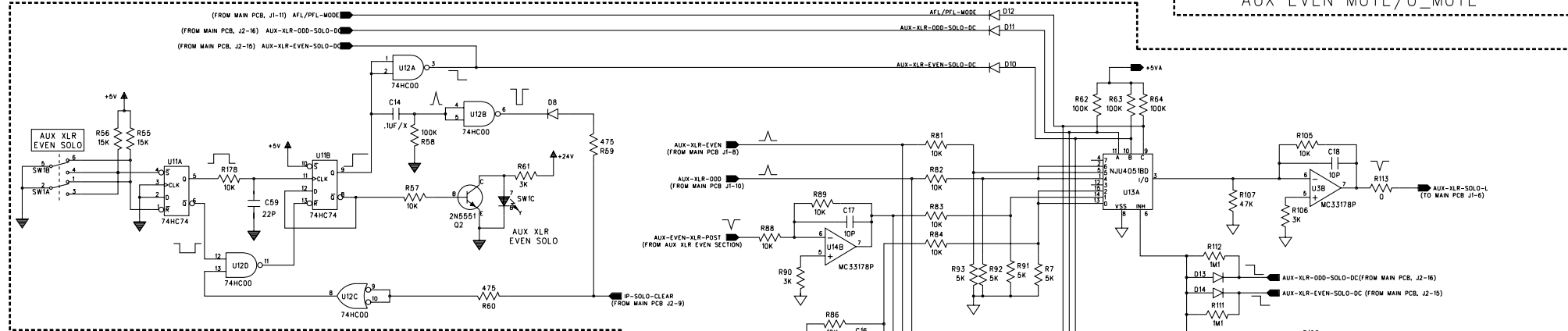
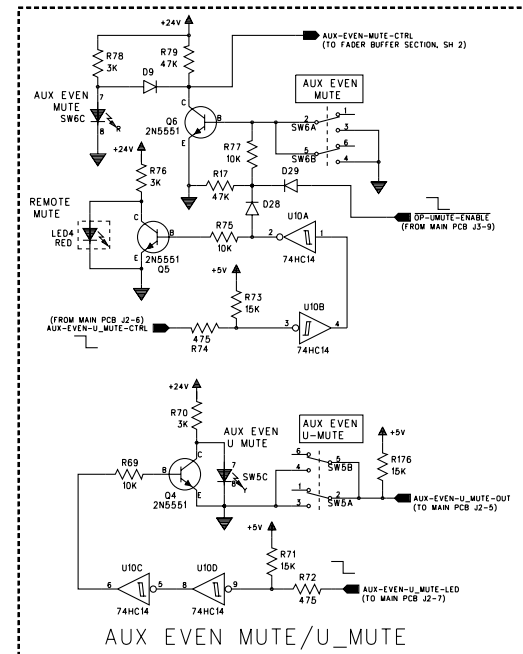
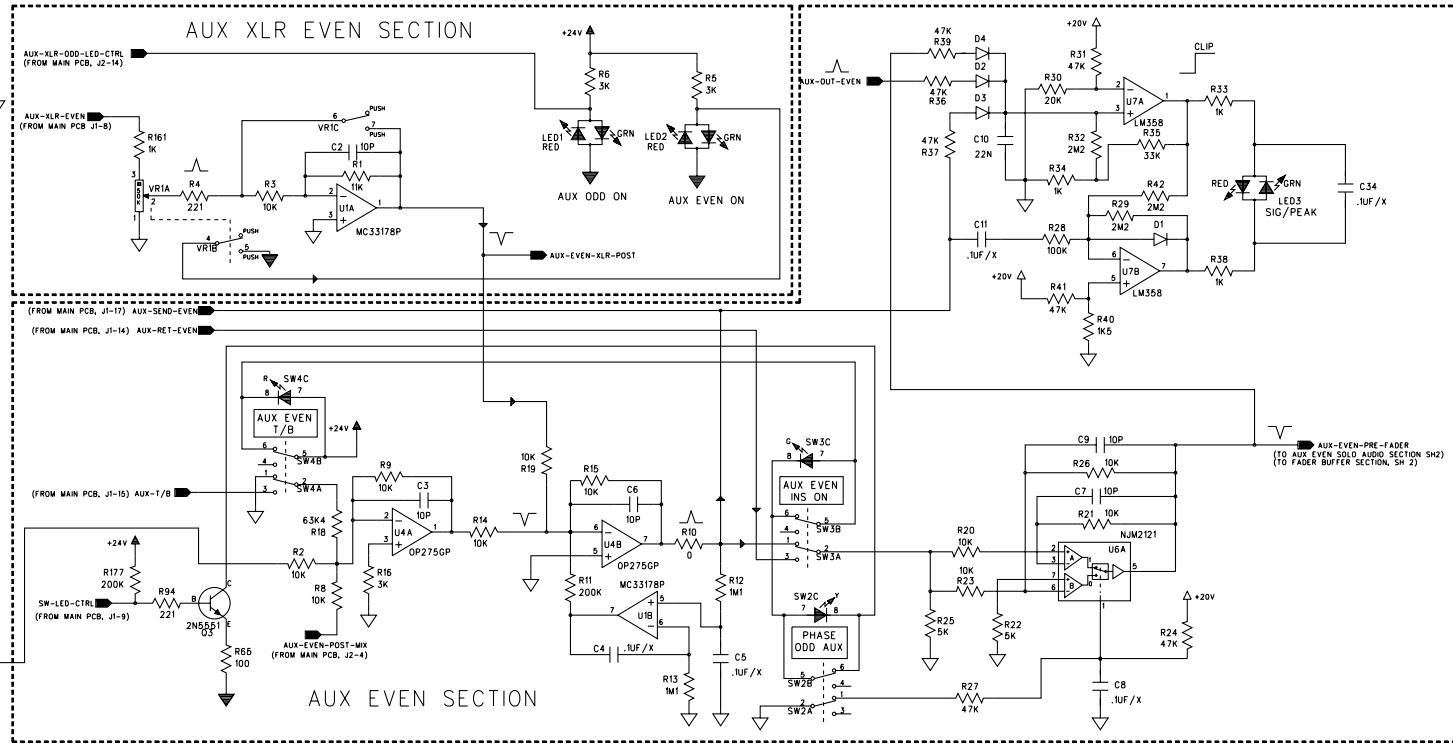
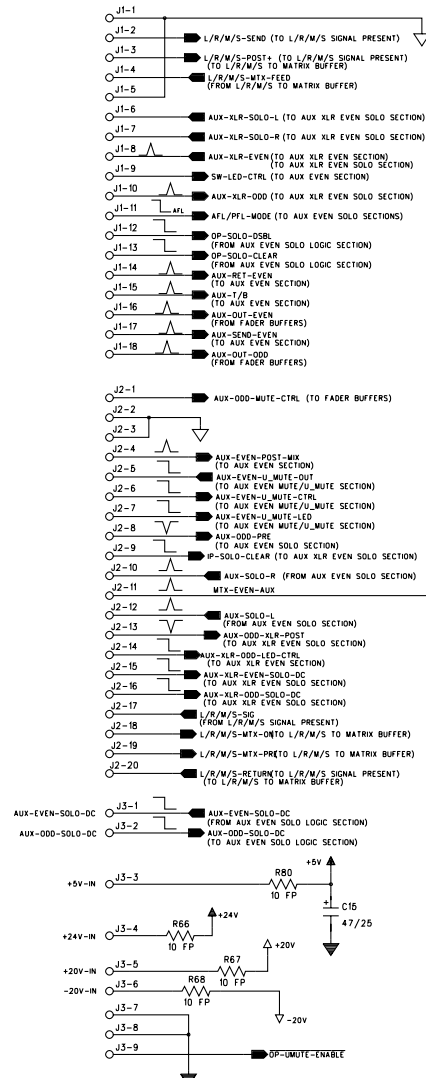

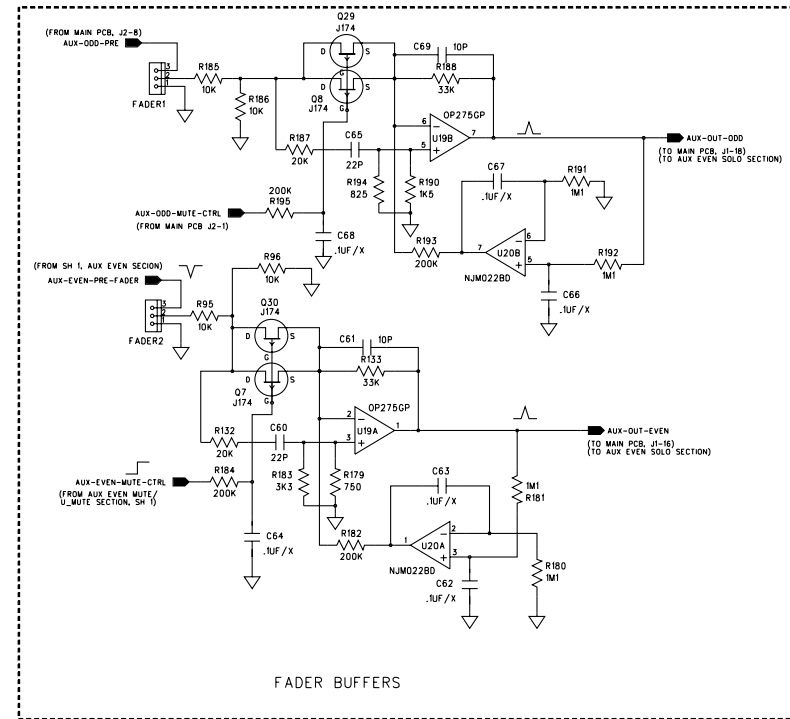
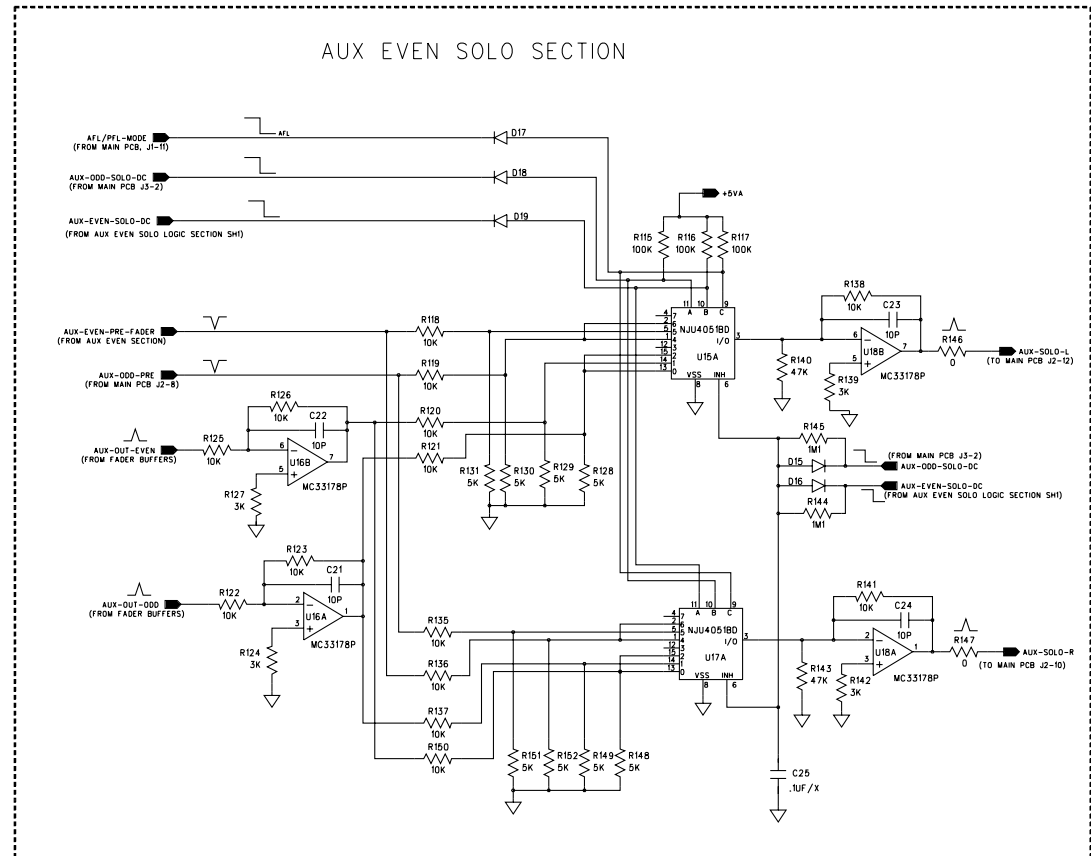

NOTES:

NOTE 1:
NETS L/R/M/S-POST+A AND L/R/M/S-POST+B
L/R/M/S-POST-A ARE THE SAME AS
L/R/M/S-POST+ AND L/R/M/S-POST-
RESPECTIVELY.

THE CHANGE IS FOR LAYOUT
PURPOSES ONLY.

NOTE 2:
ALL HEADERS (HDR 2-5) OF THE
FET SUB PCB ARE CONNECTED
ON THE MAIN PCB. THIS SUB BOARD
IS PHYSICALLY SEPARATED FROM THE
"MAIN" SUB PCB.

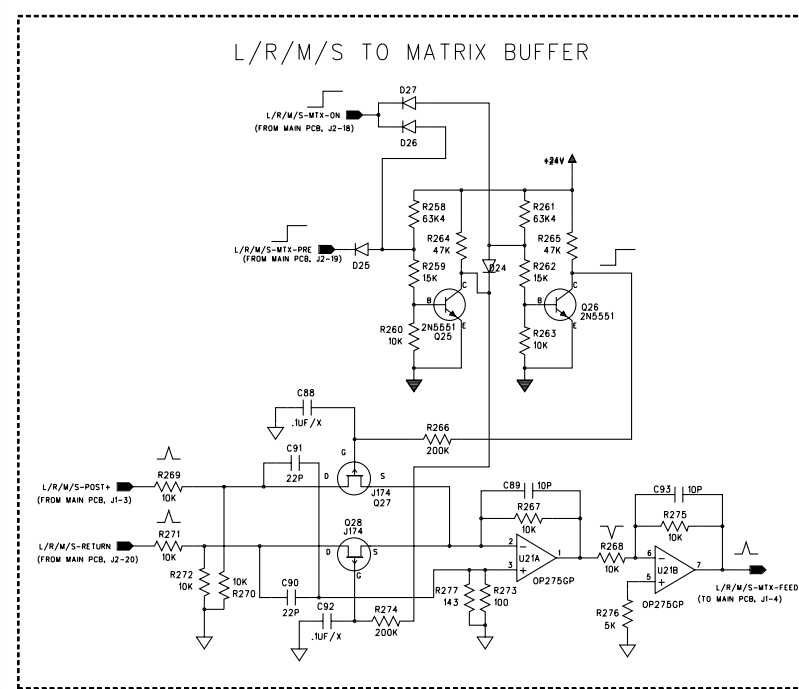
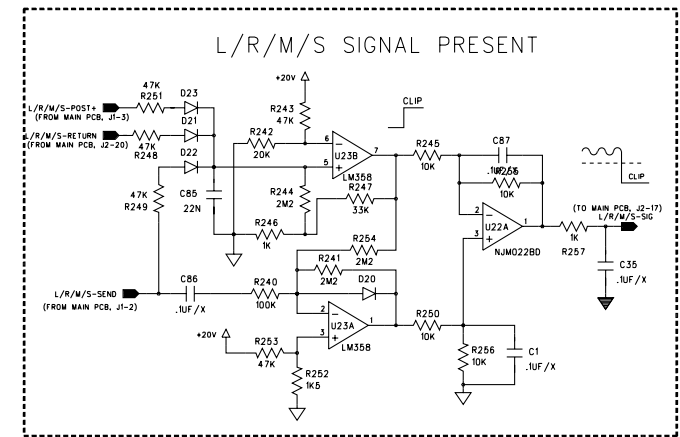
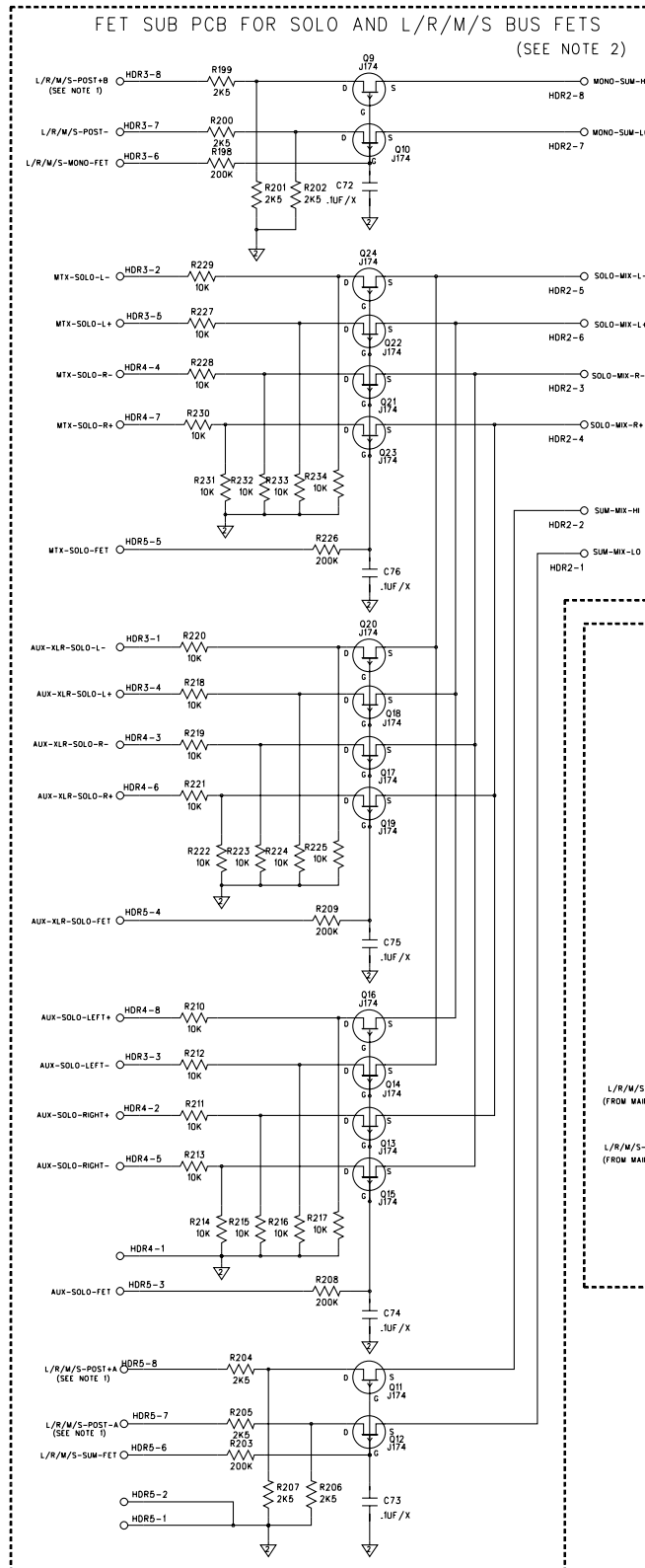

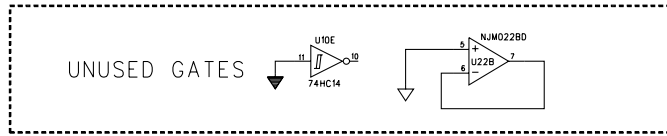
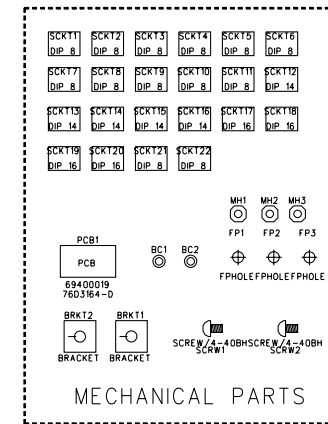
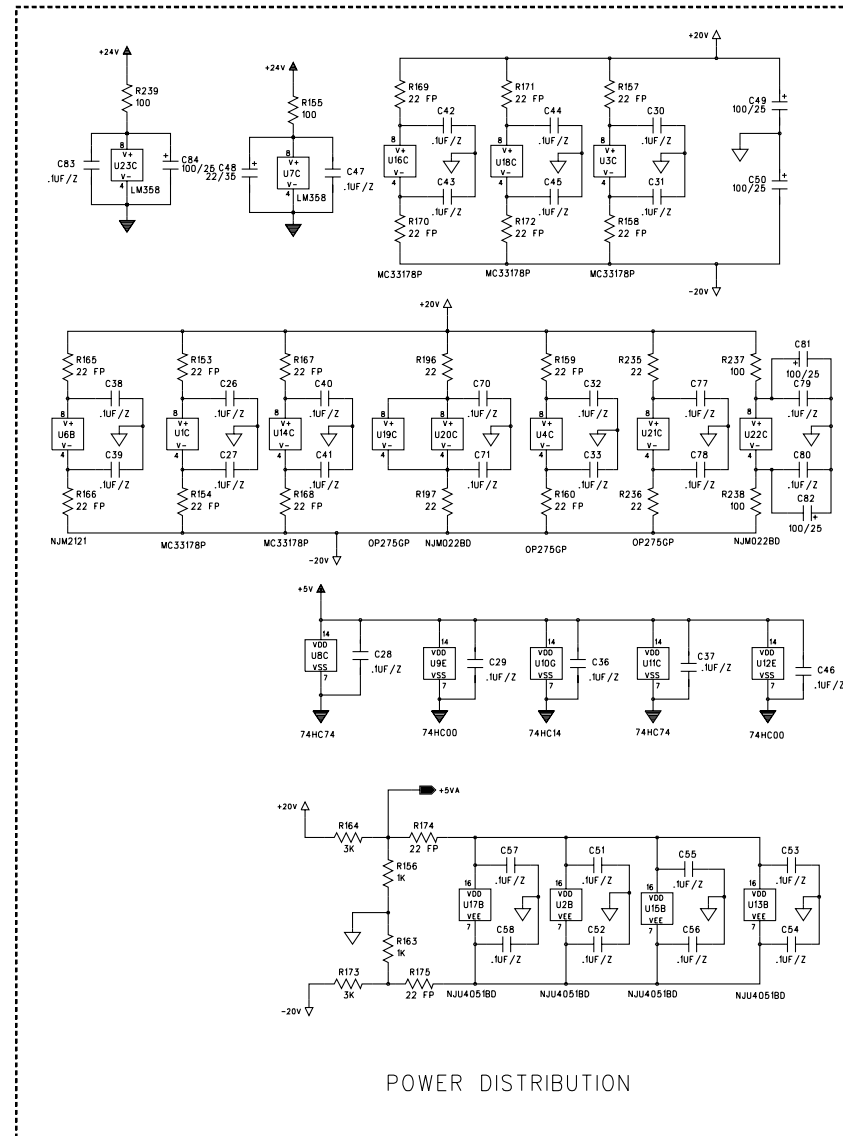

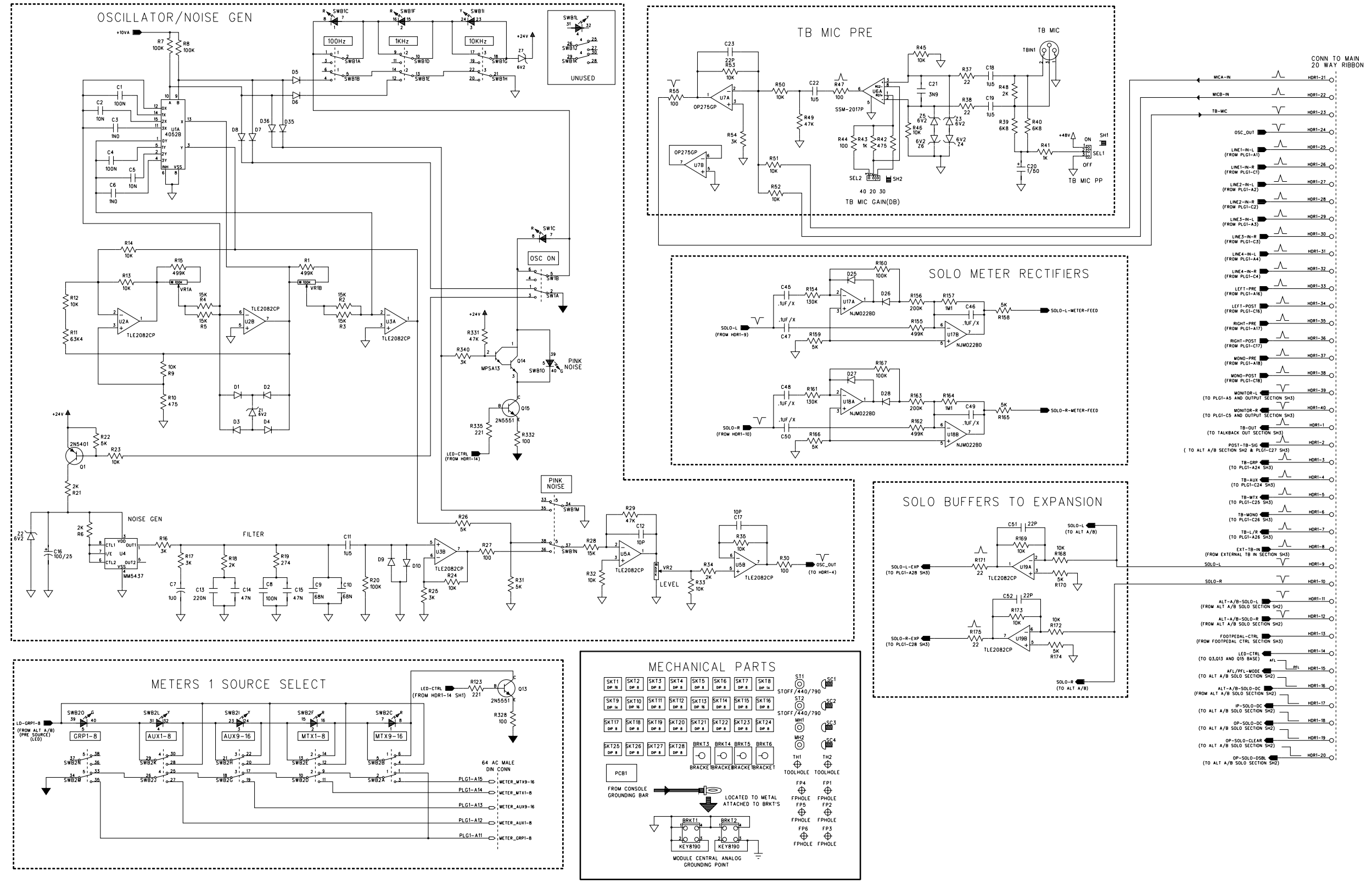

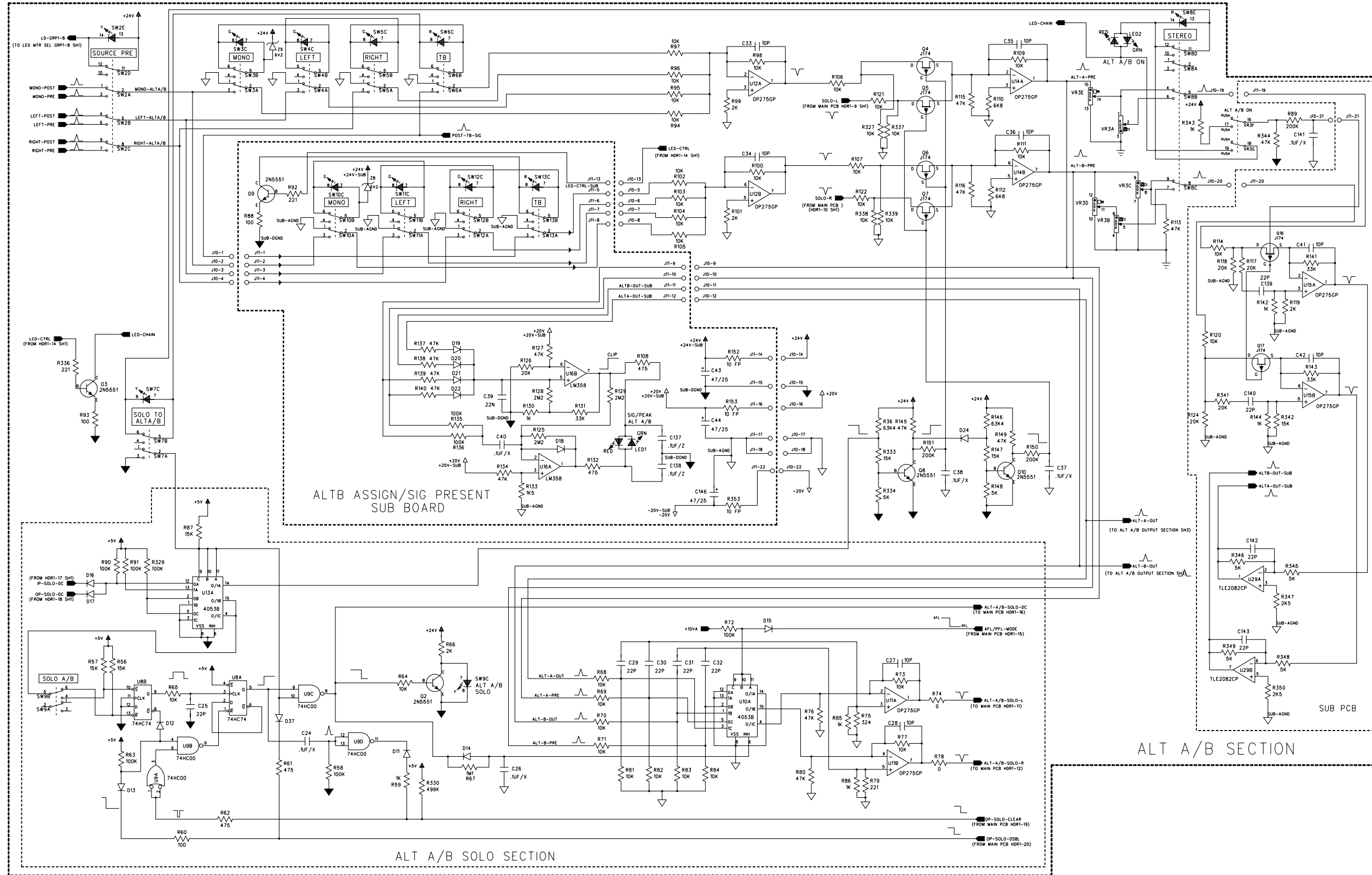

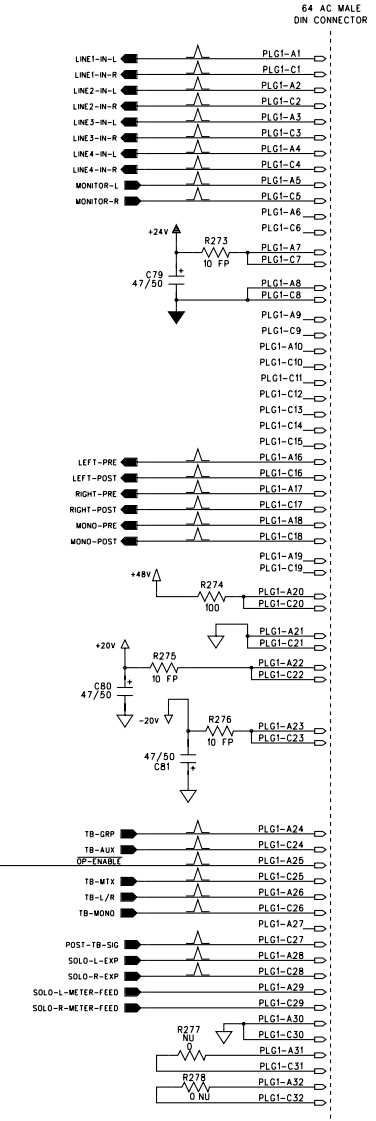
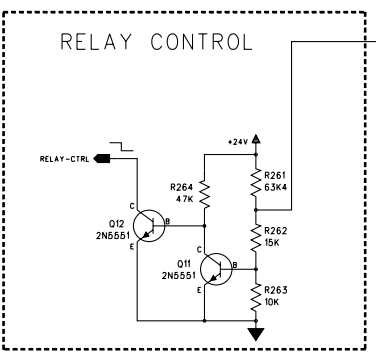
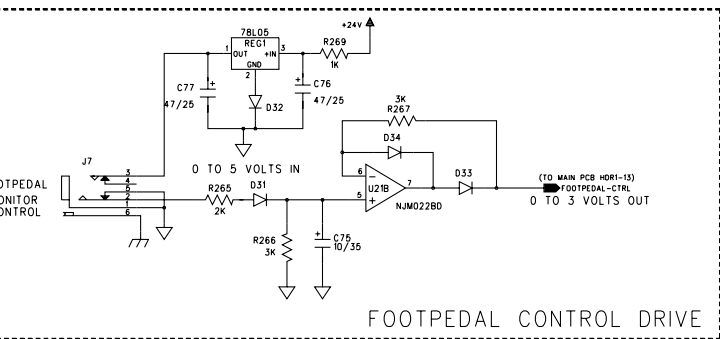
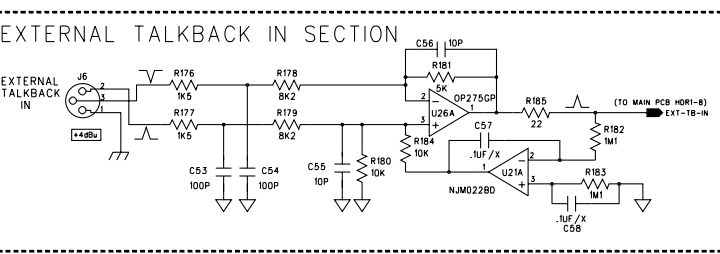
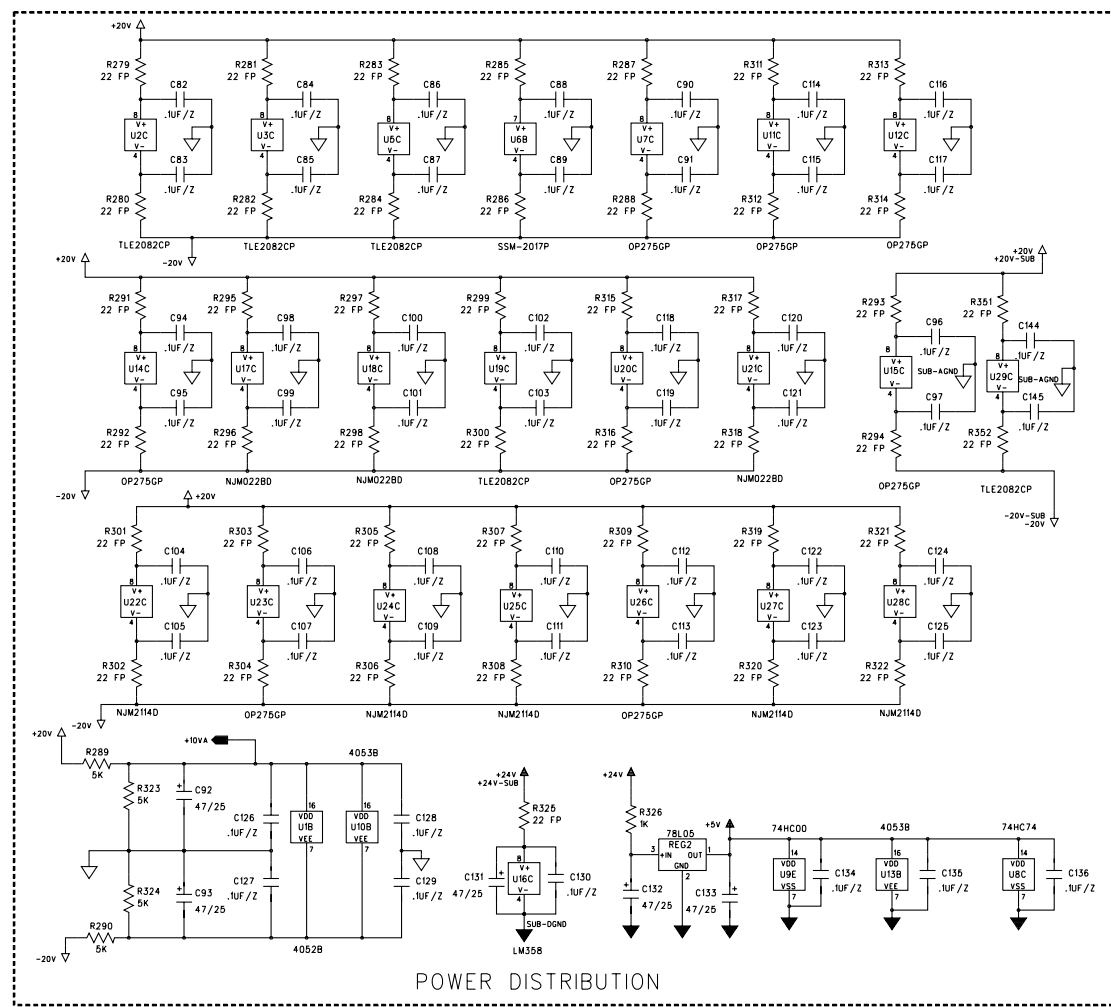
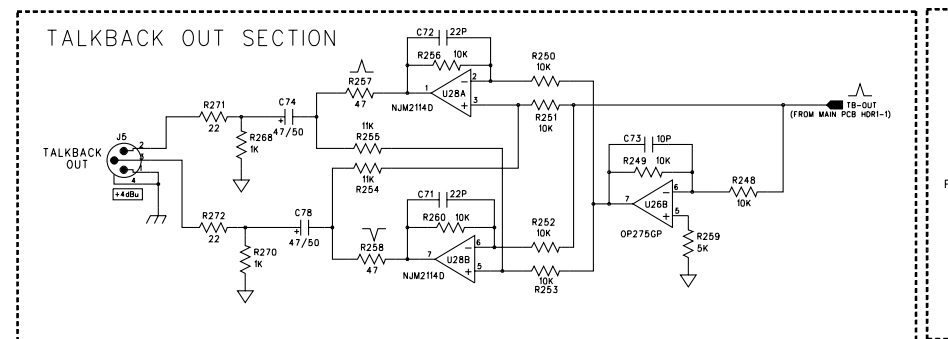
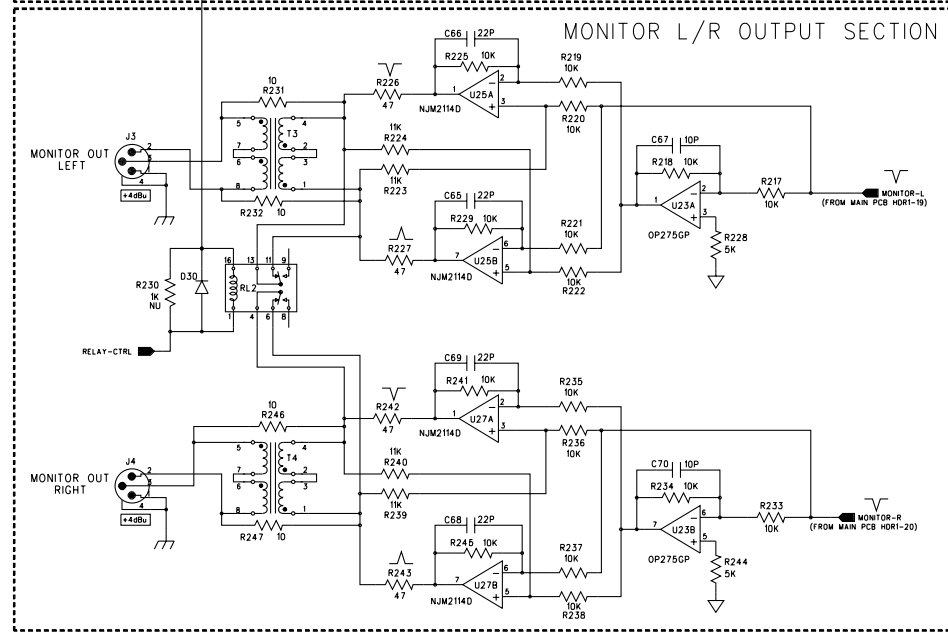
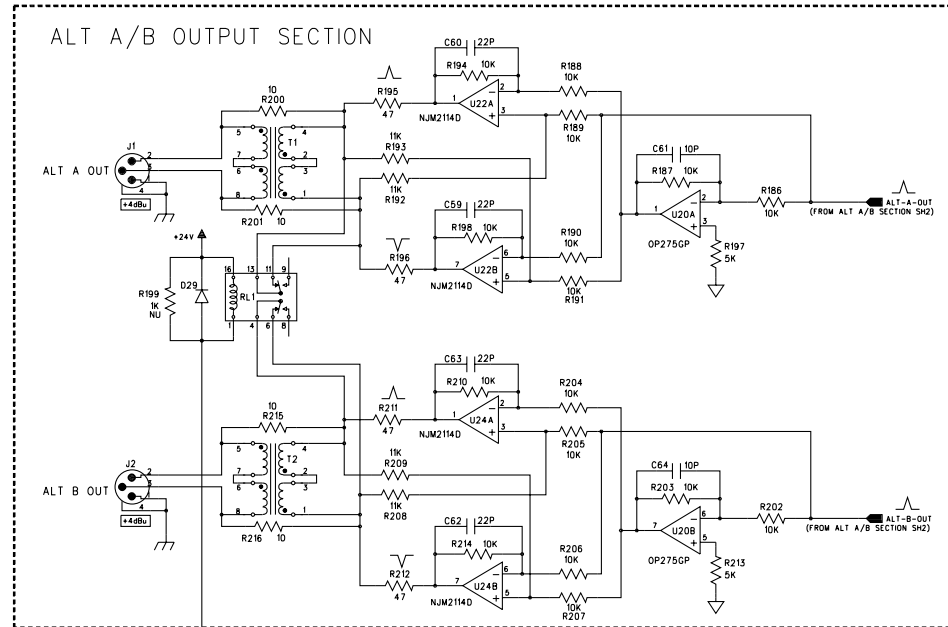

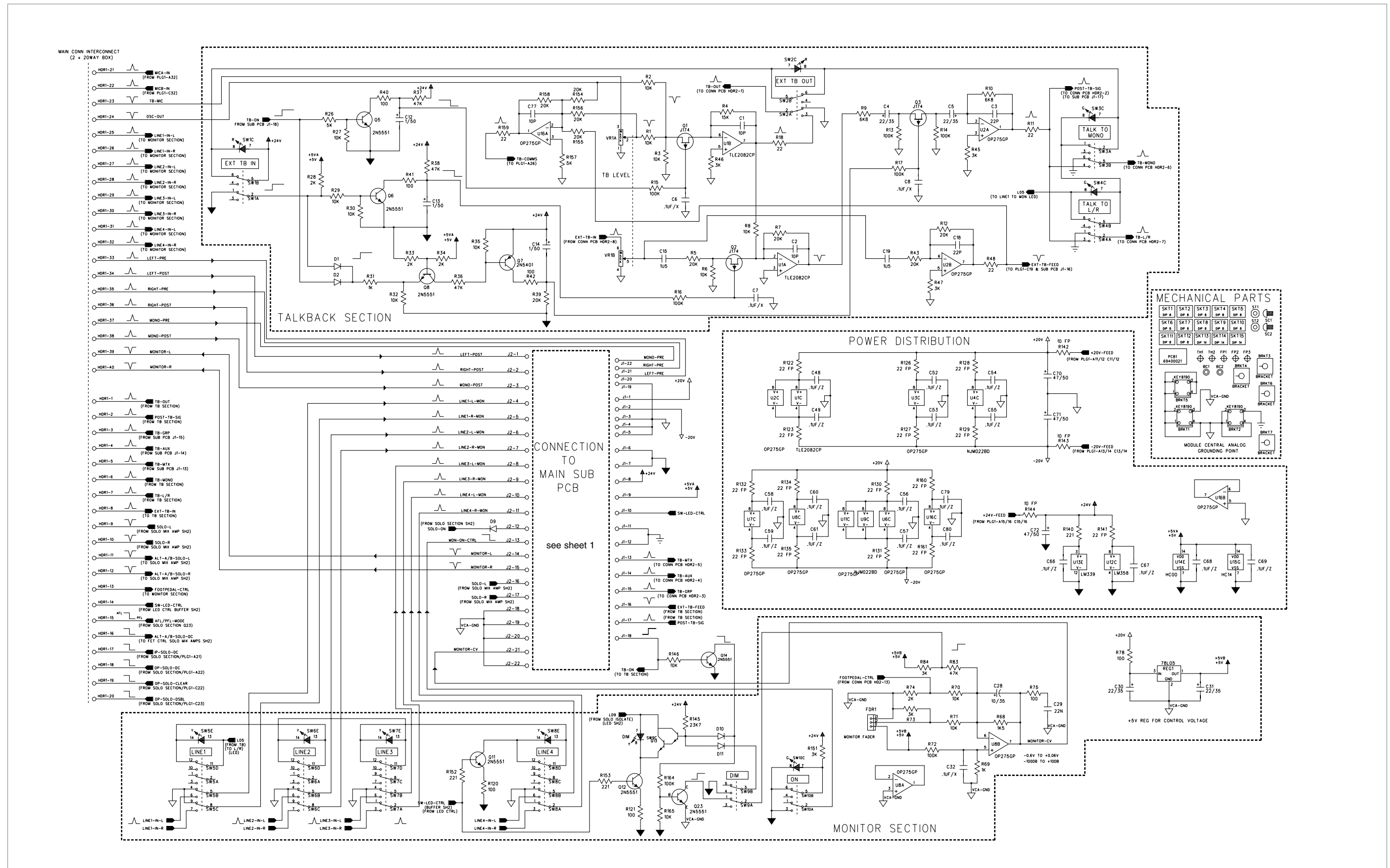

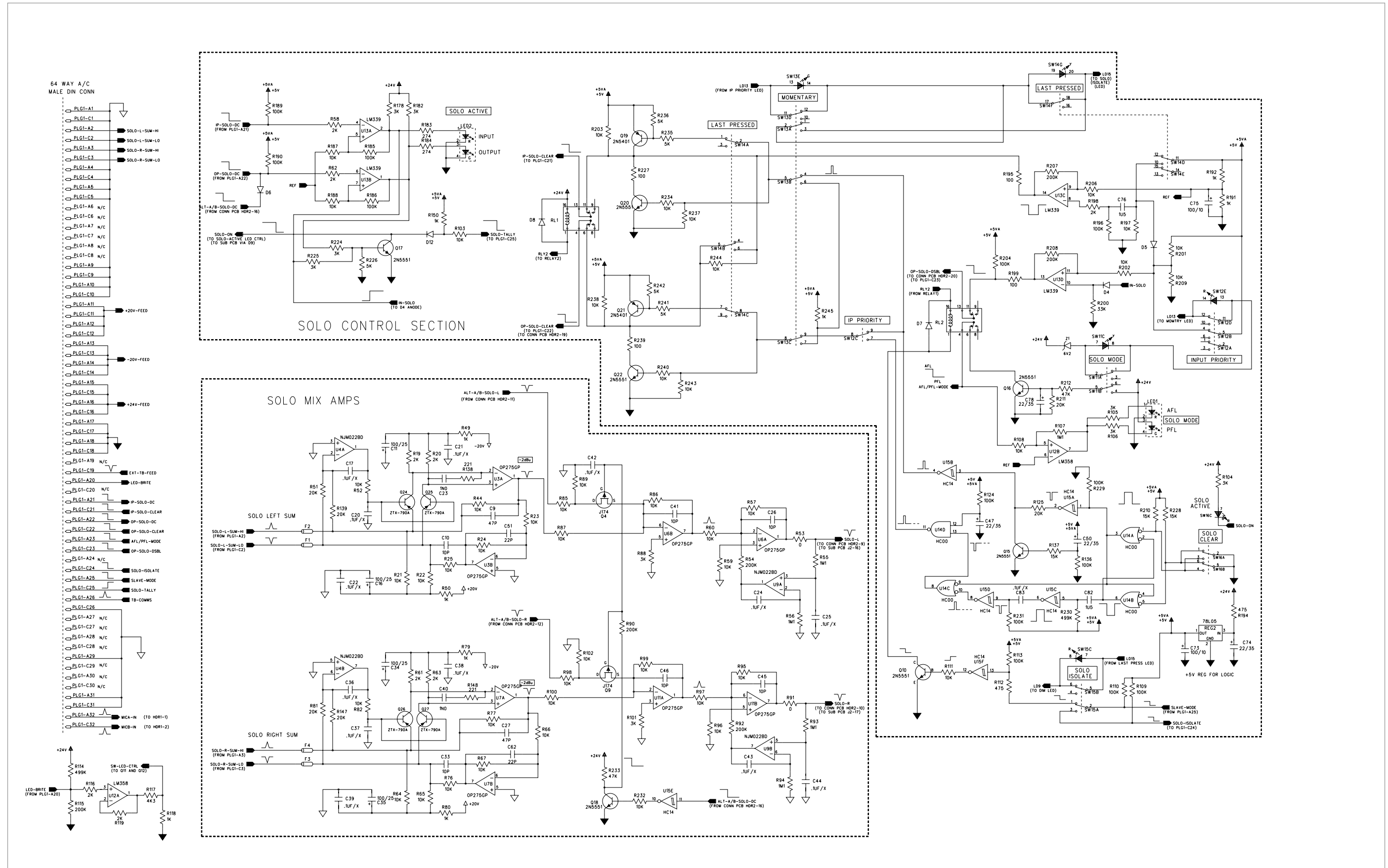

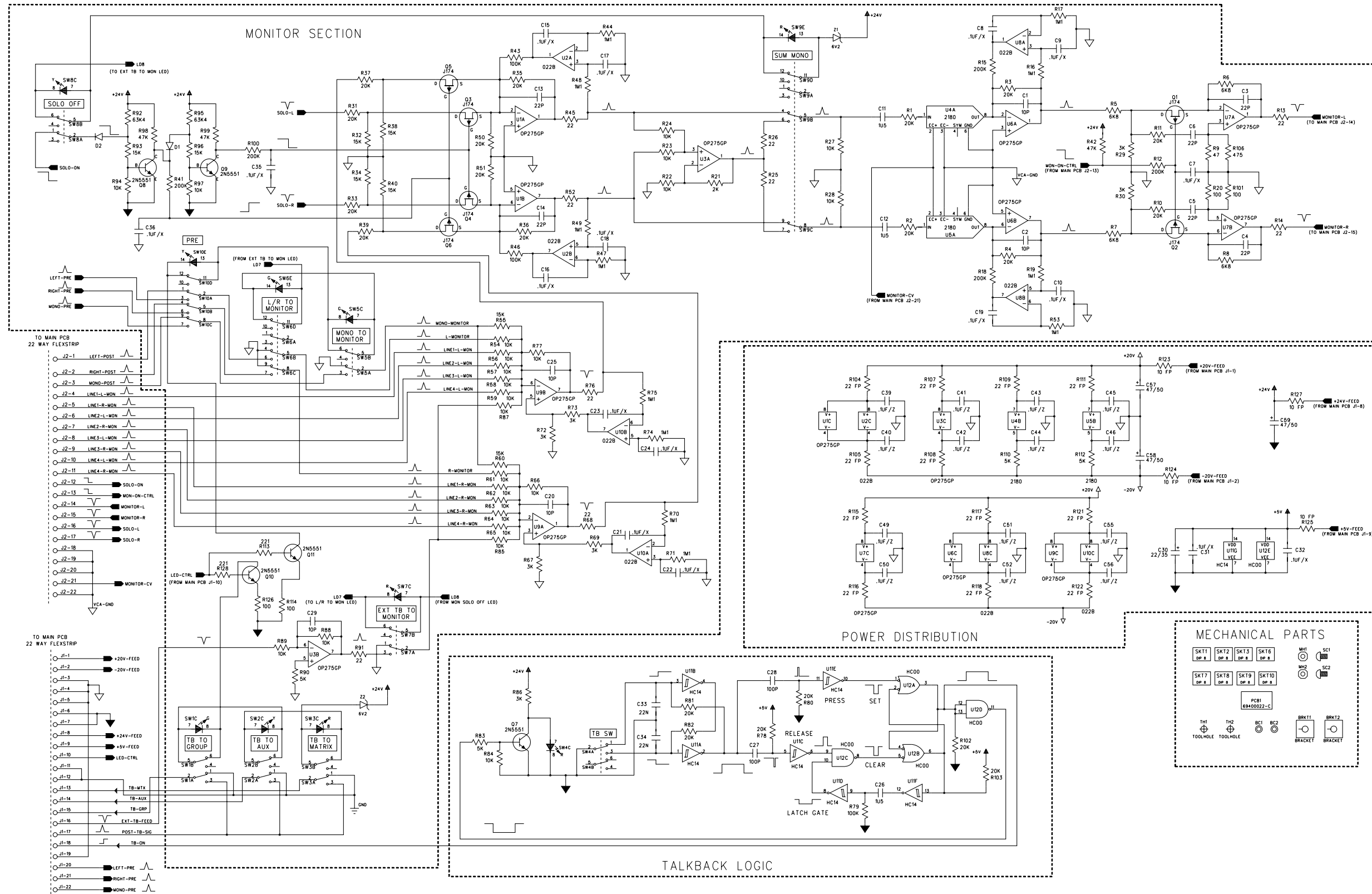

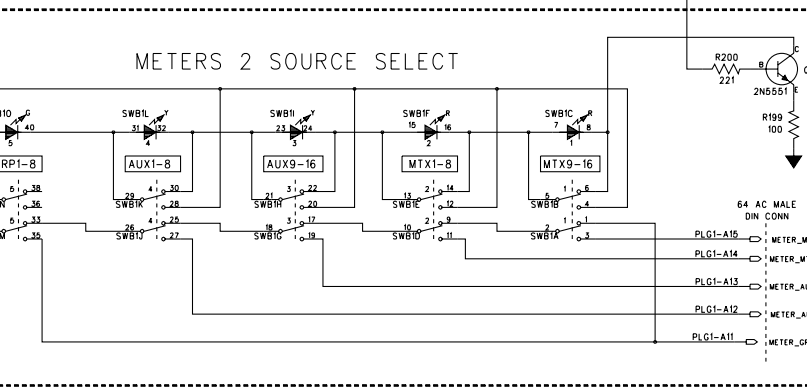
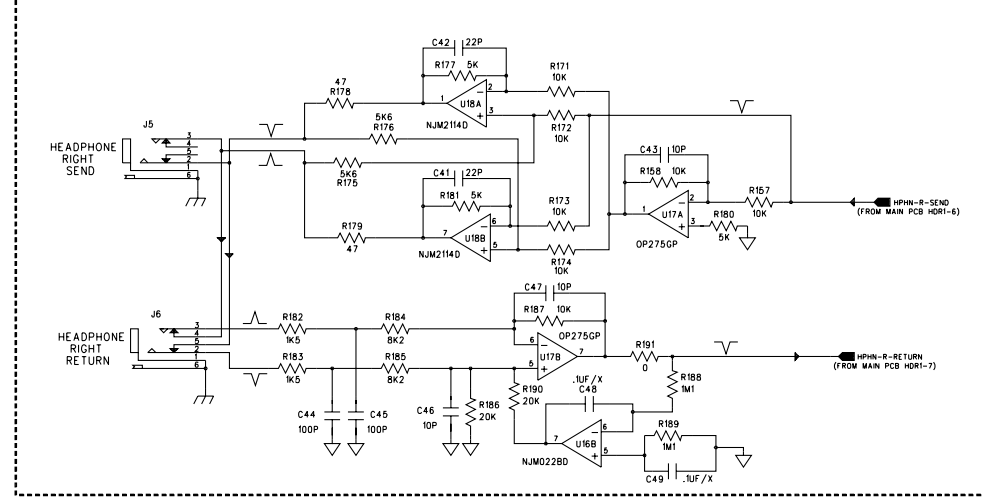
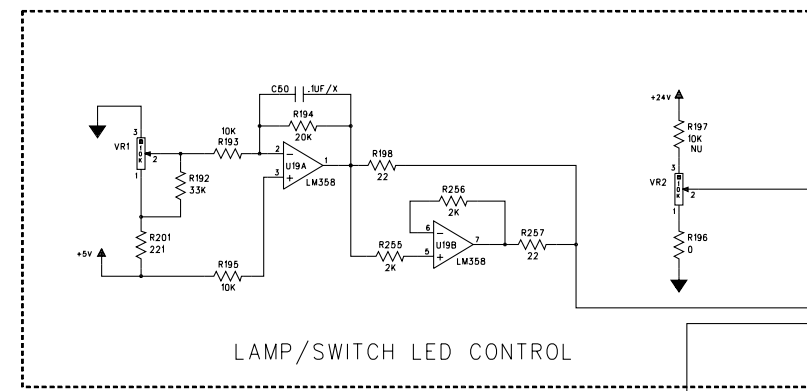
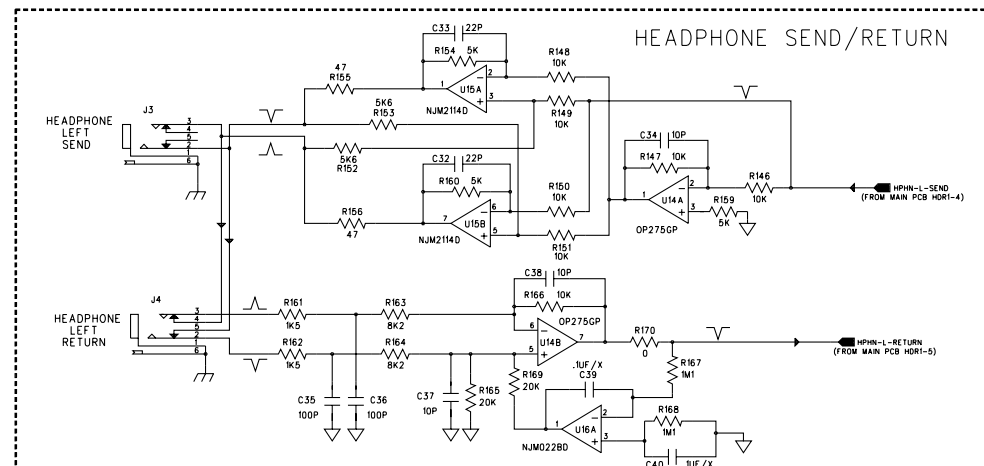
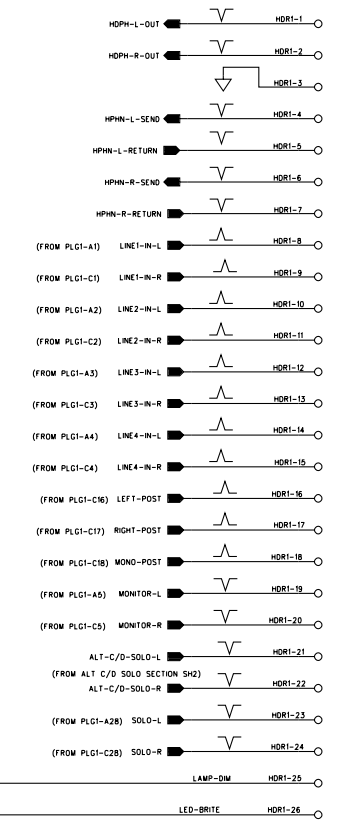
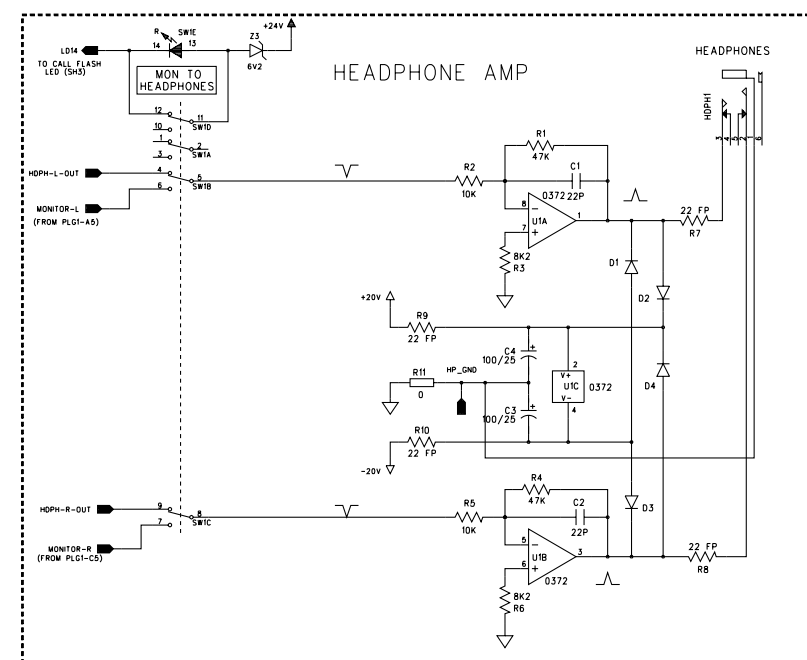
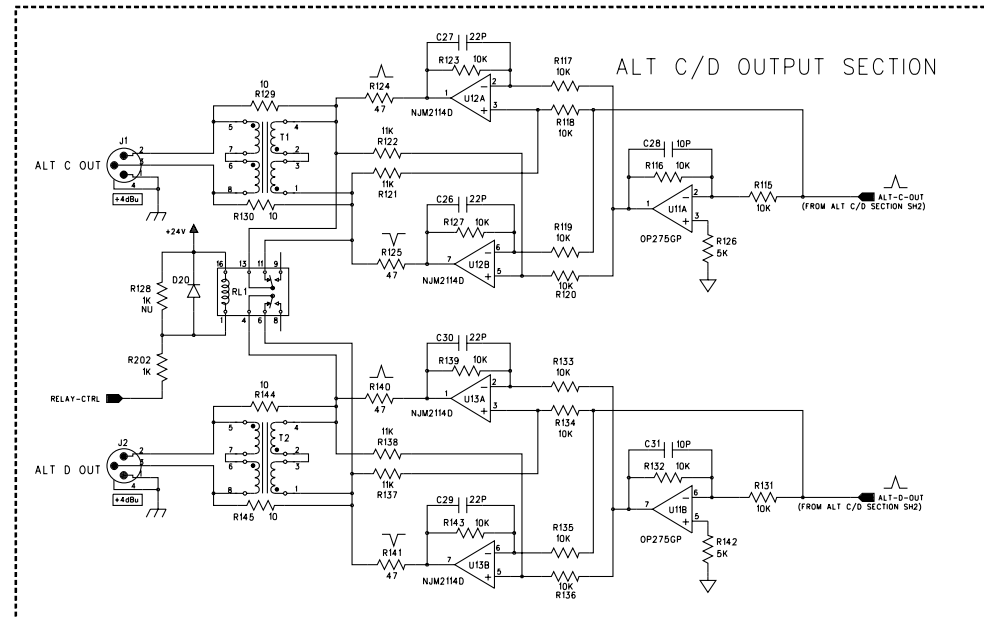

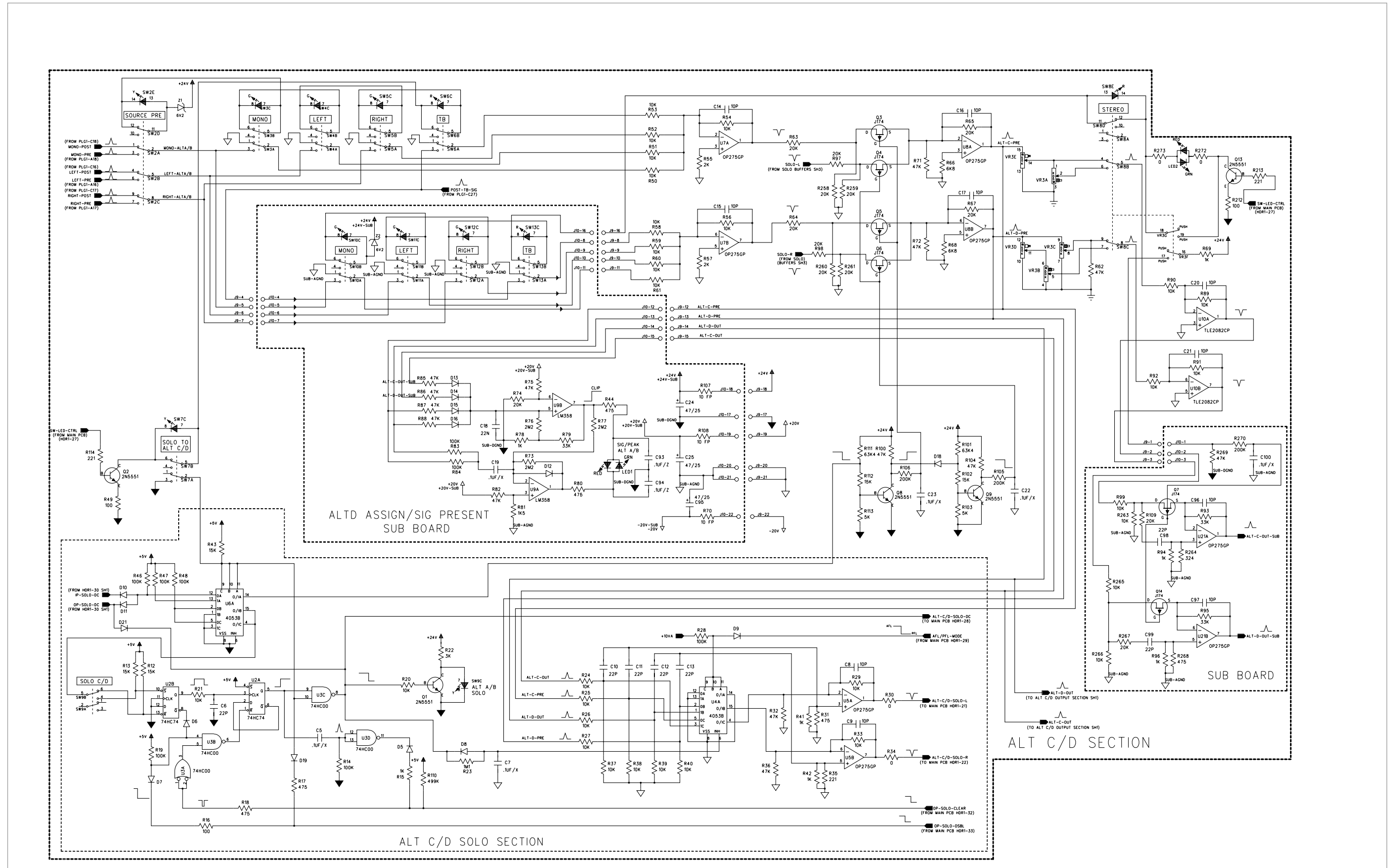

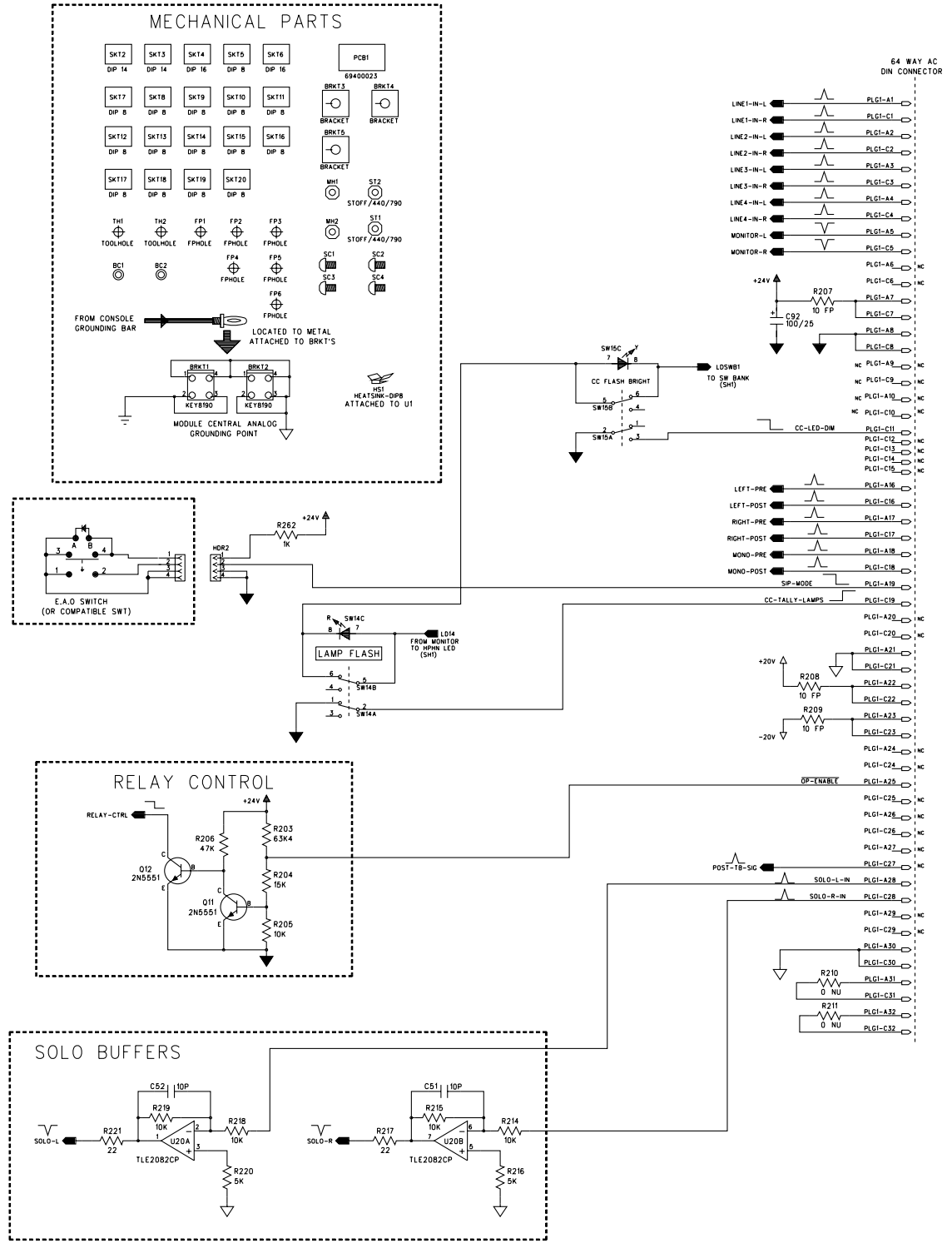
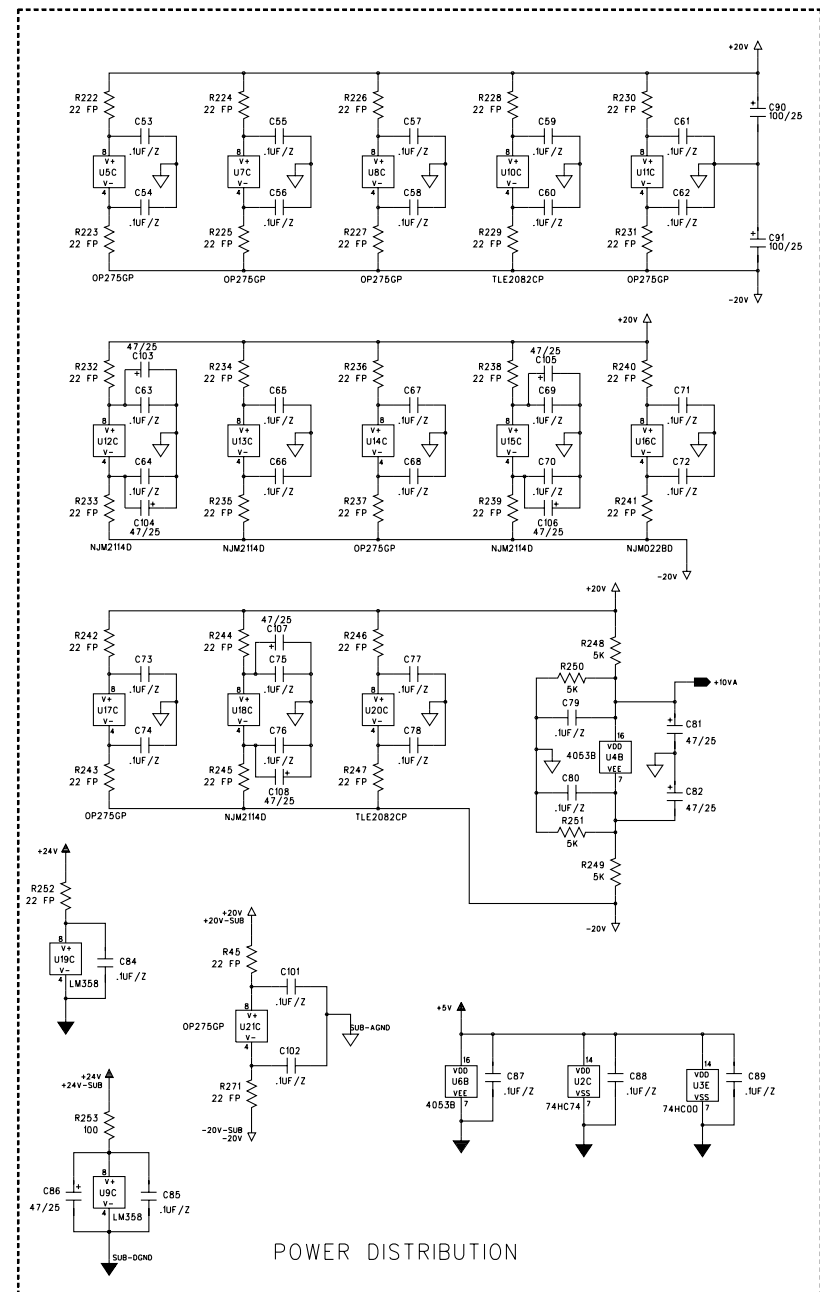

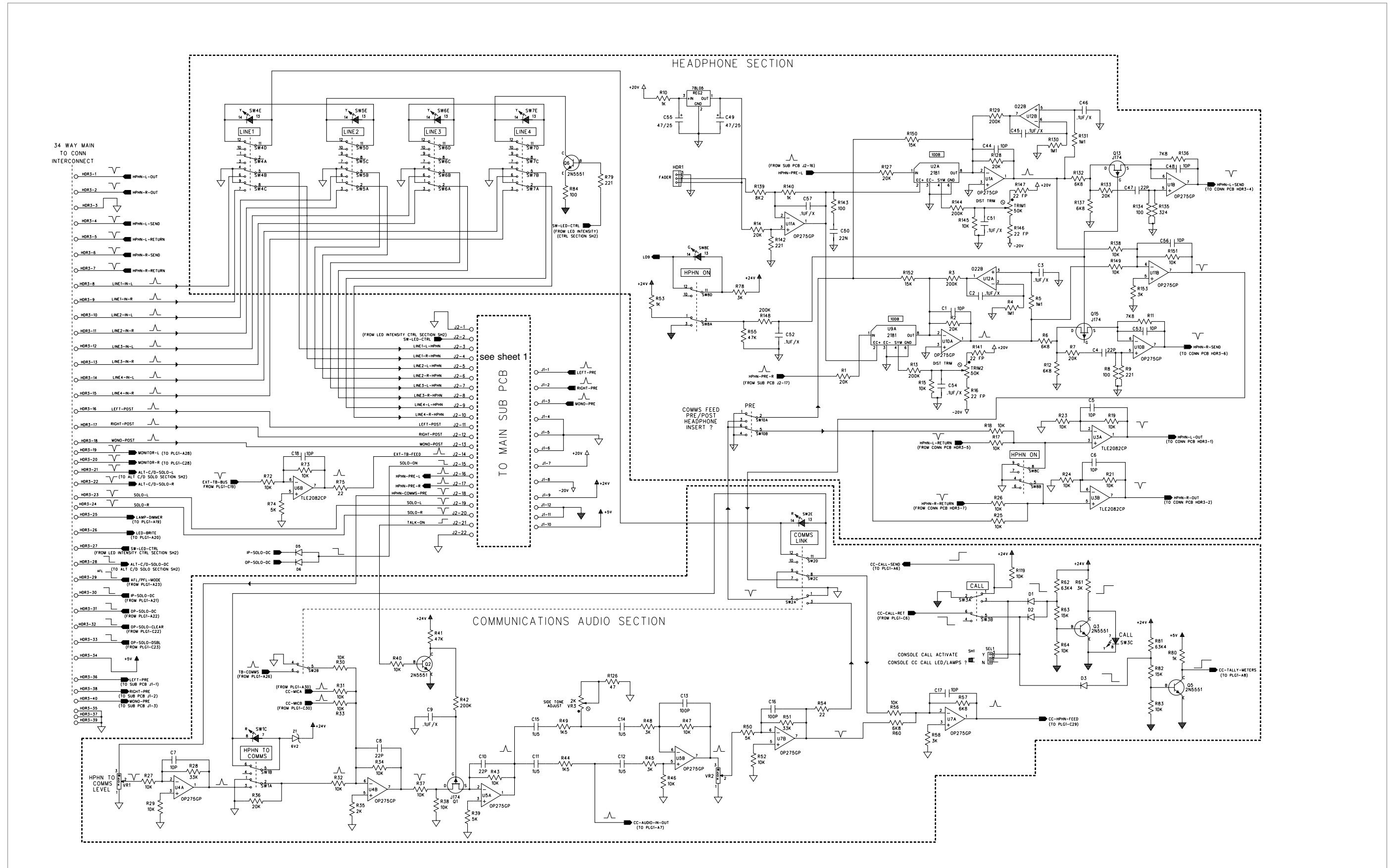

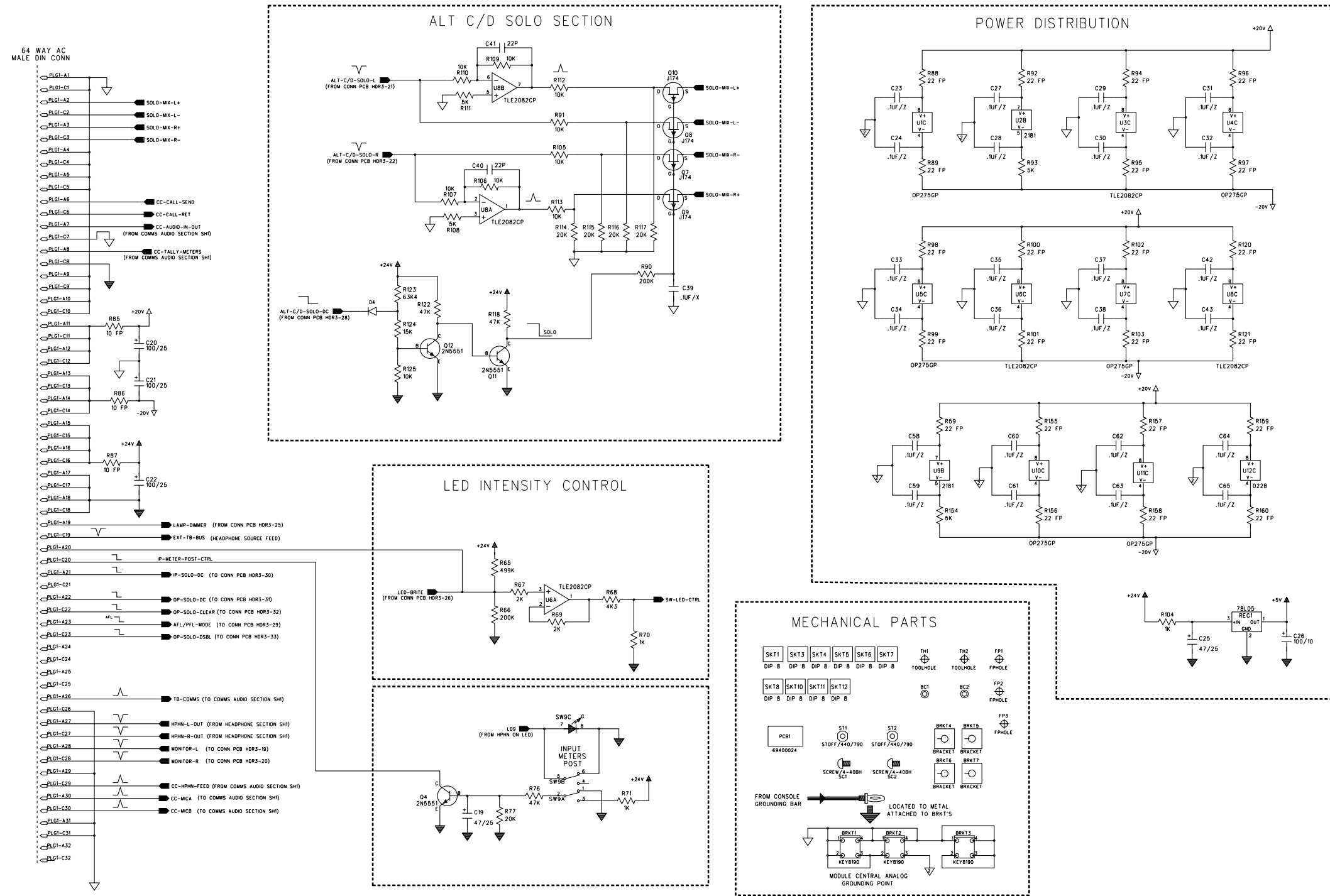

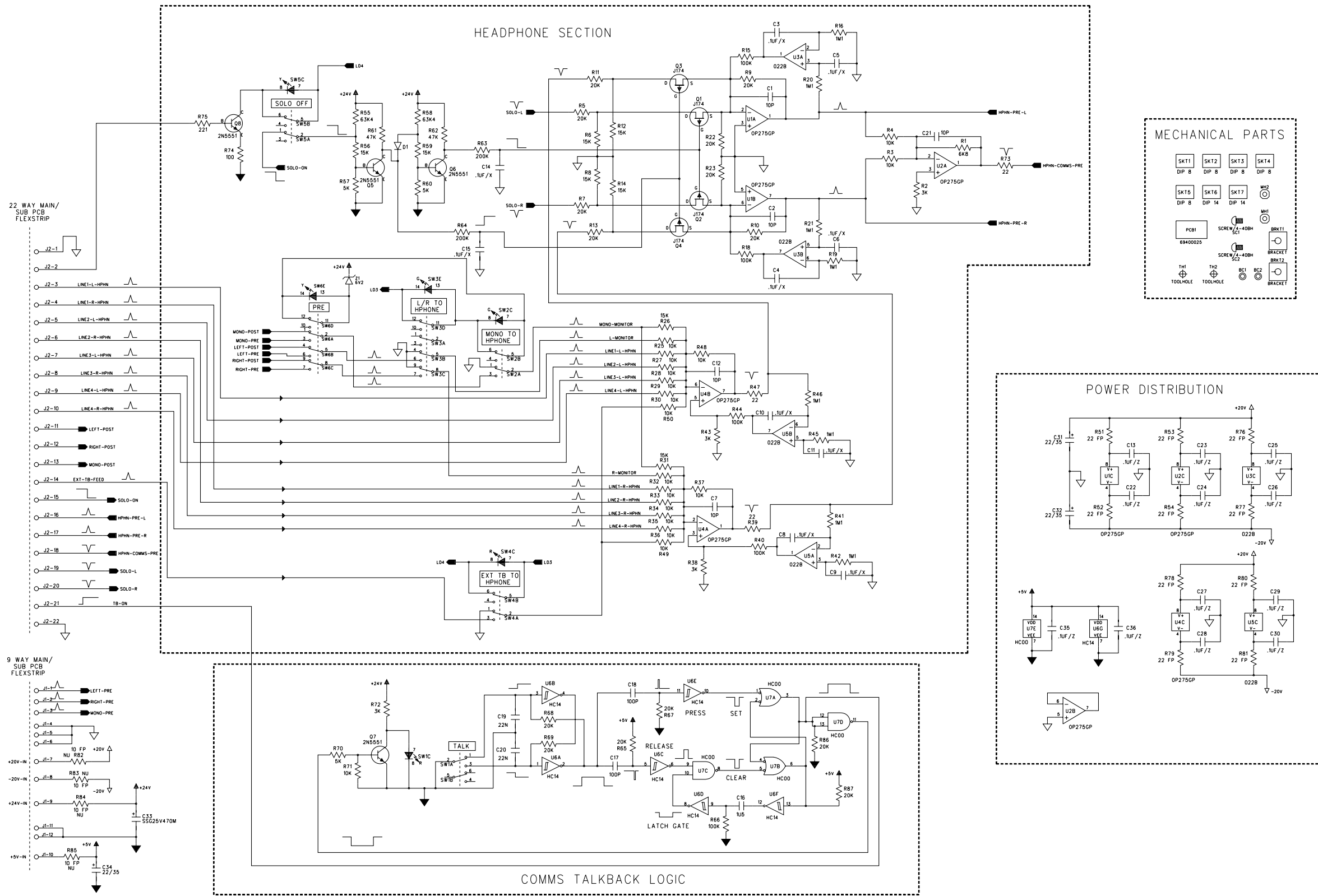

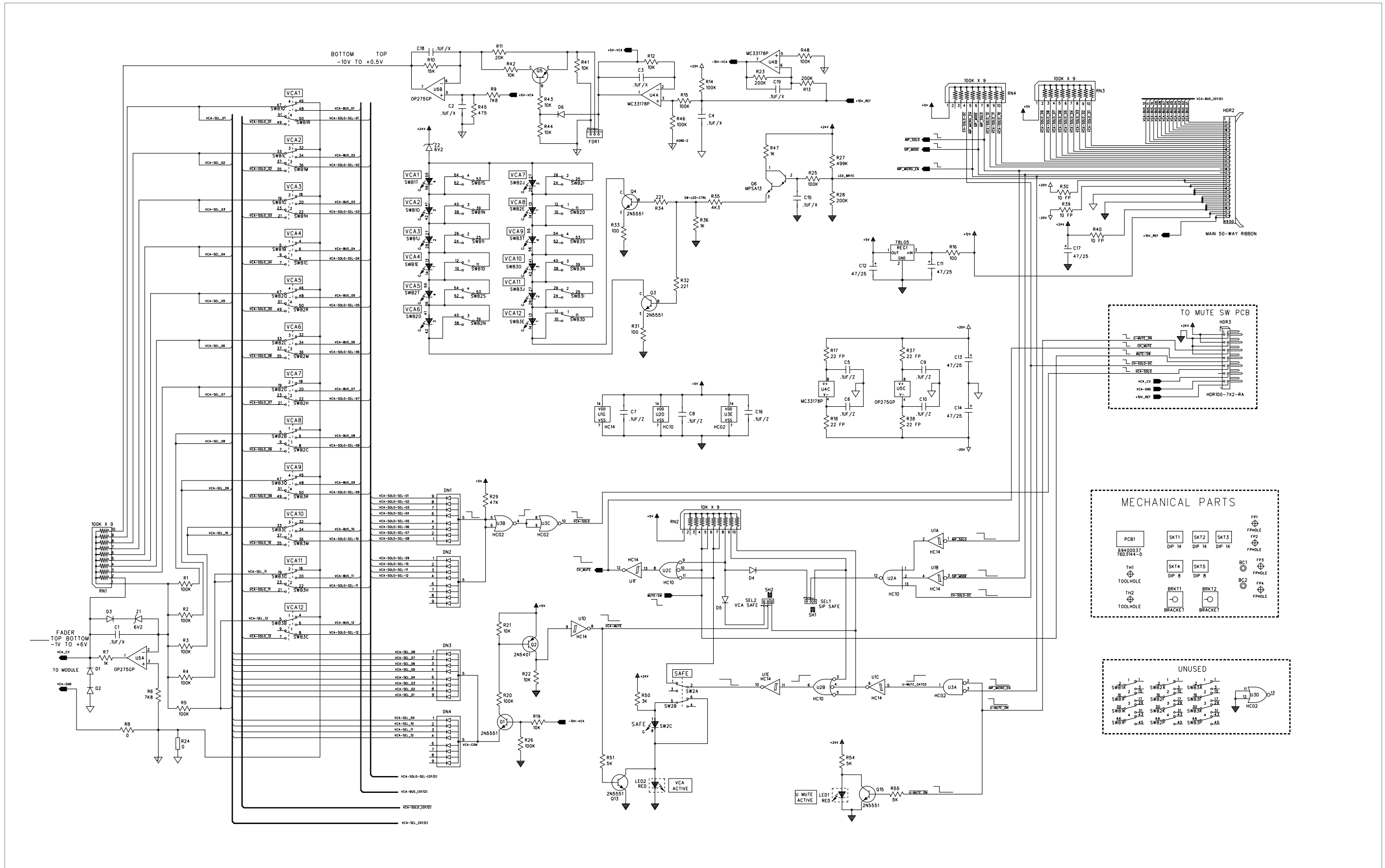

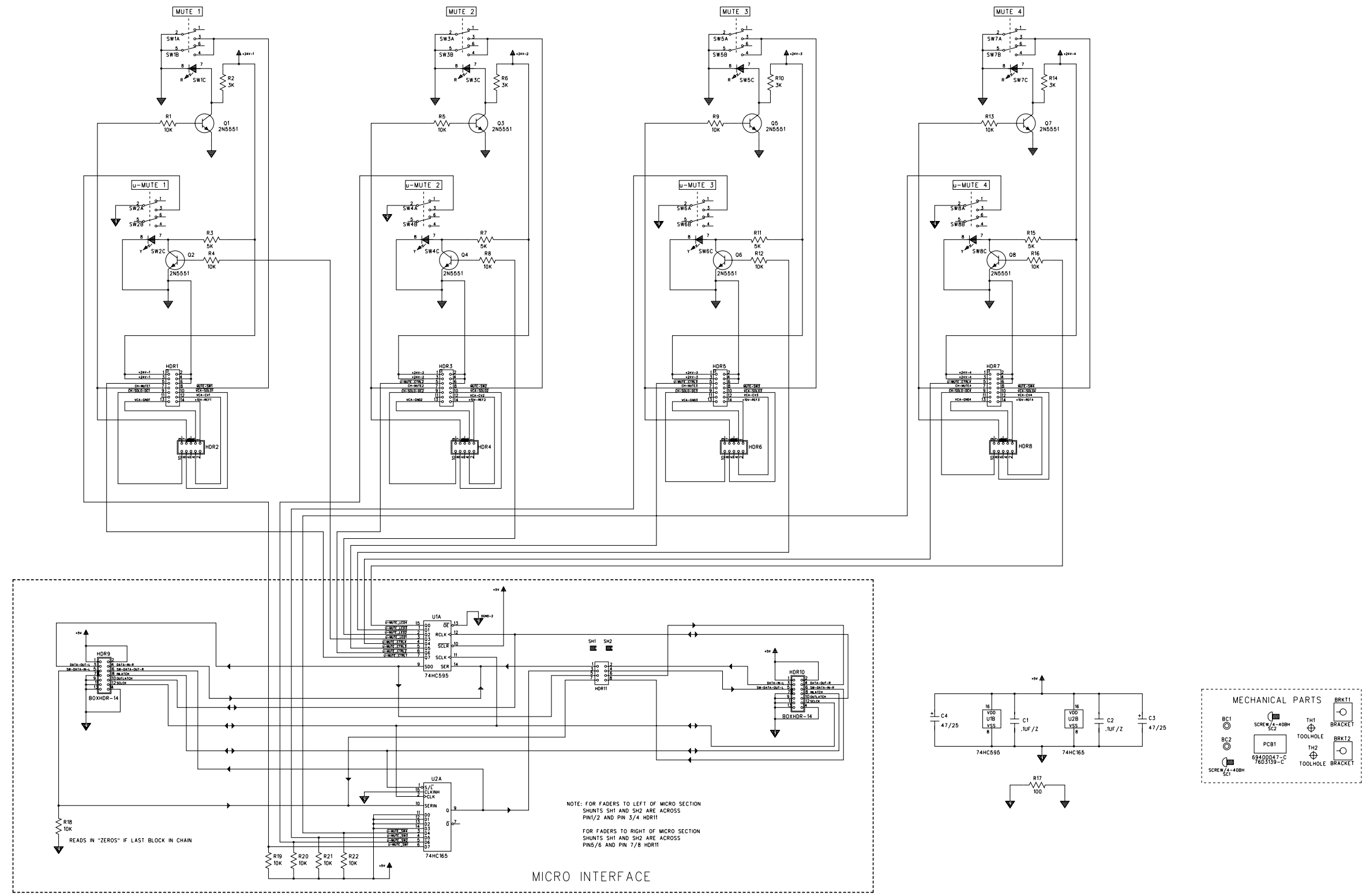

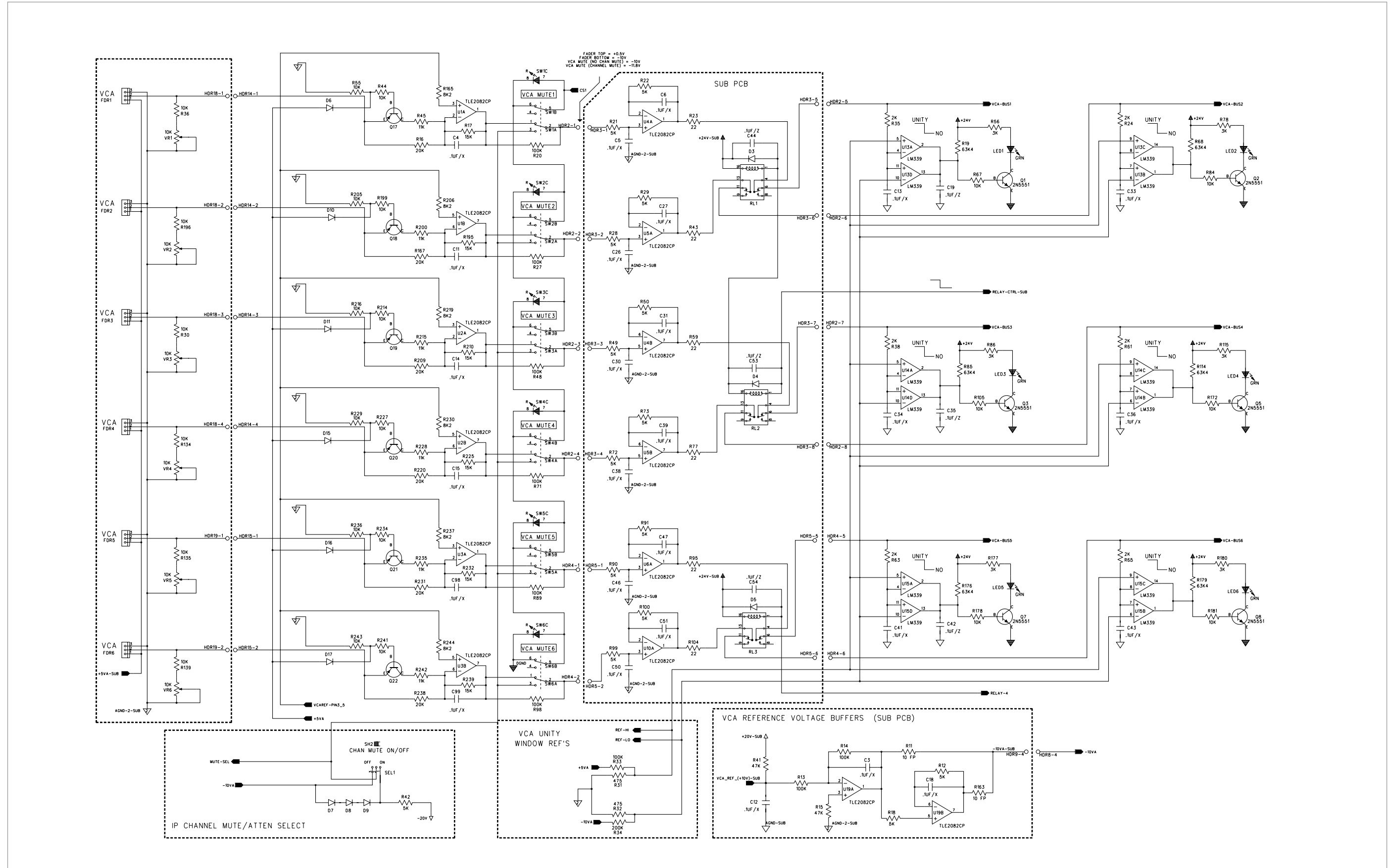

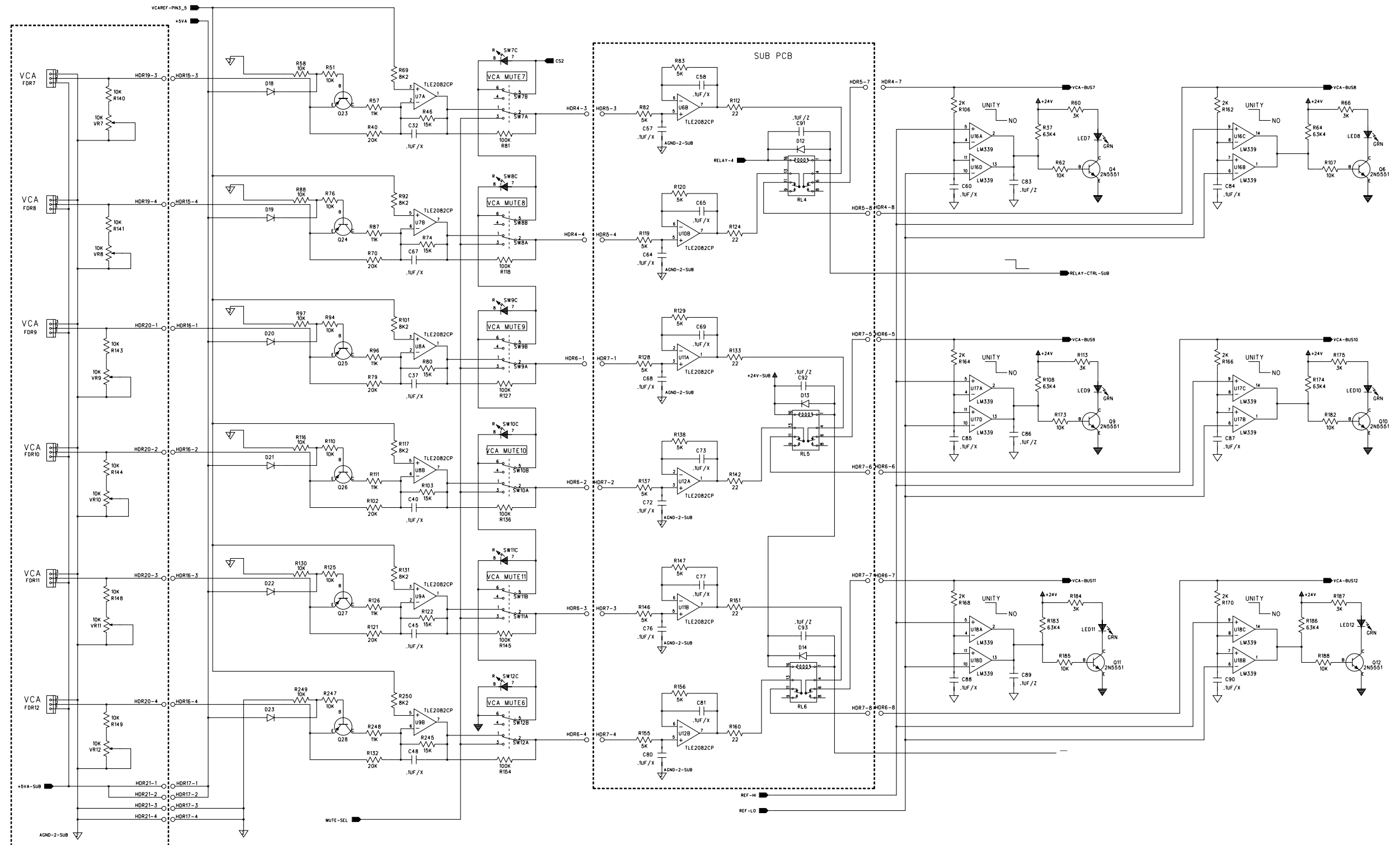

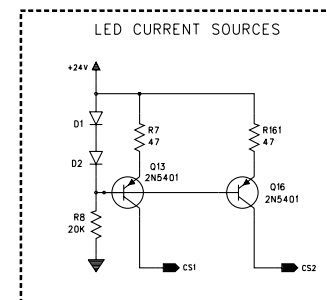
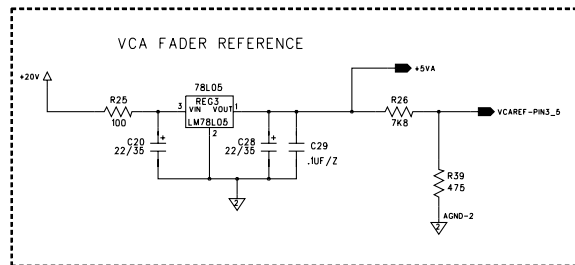
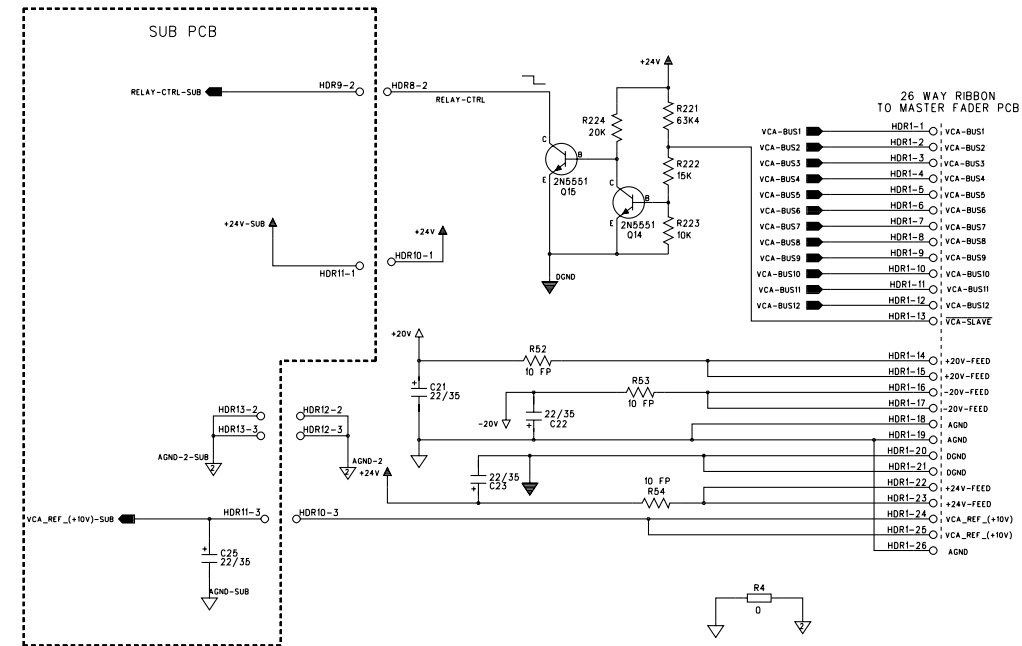
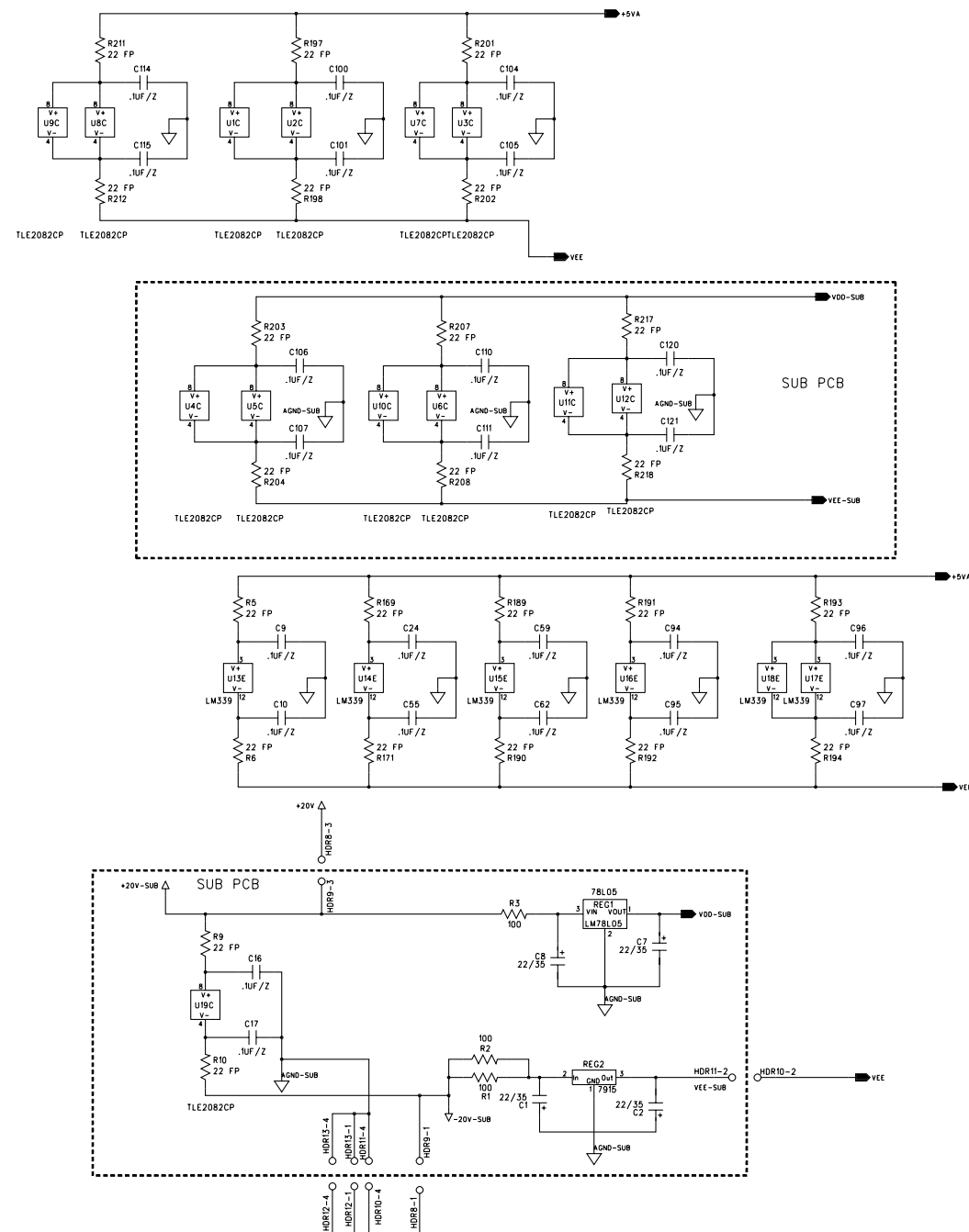

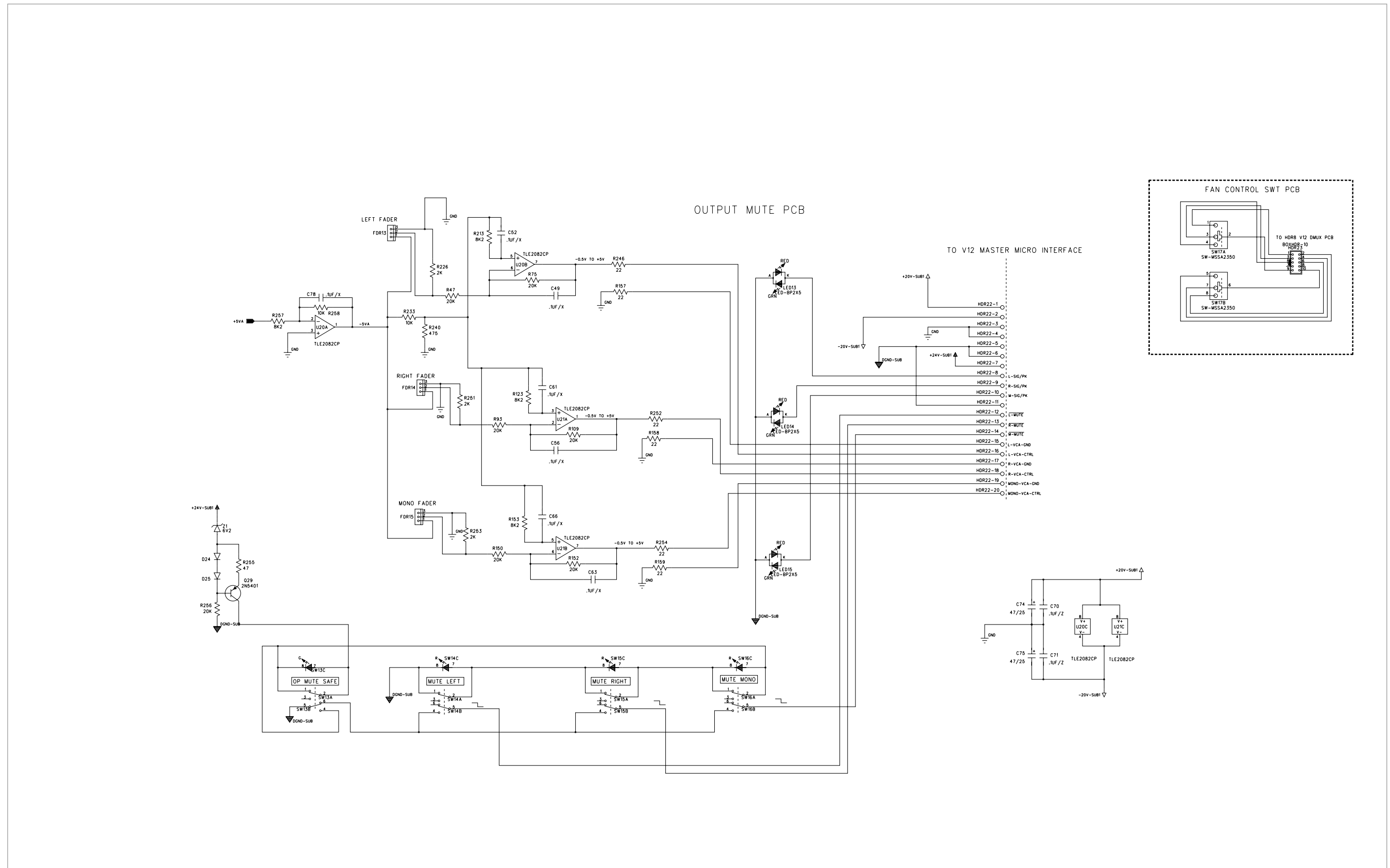

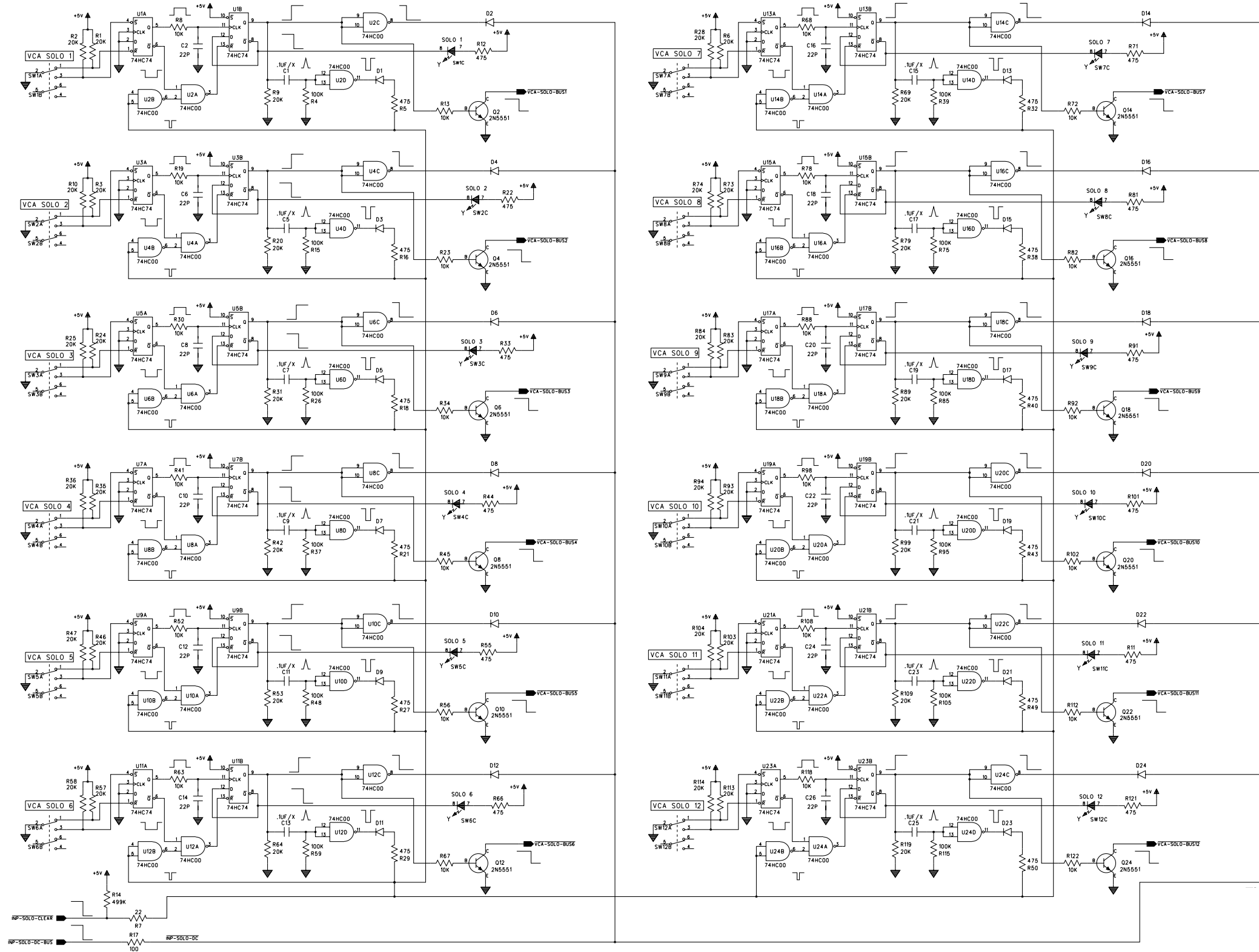

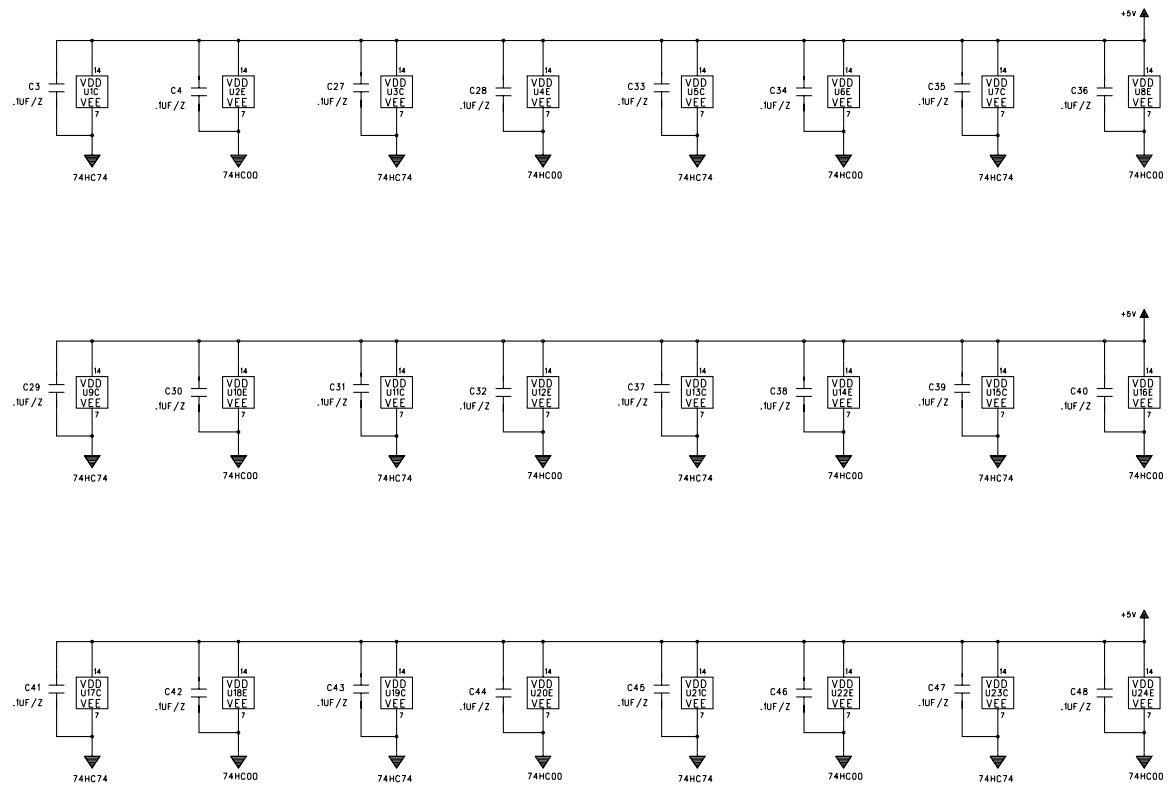

20 WAY RIBBON TO MASTER FADER PCB

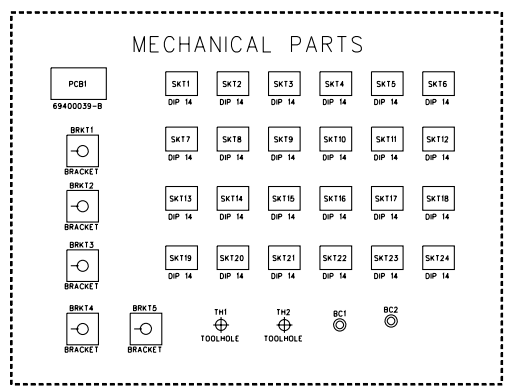
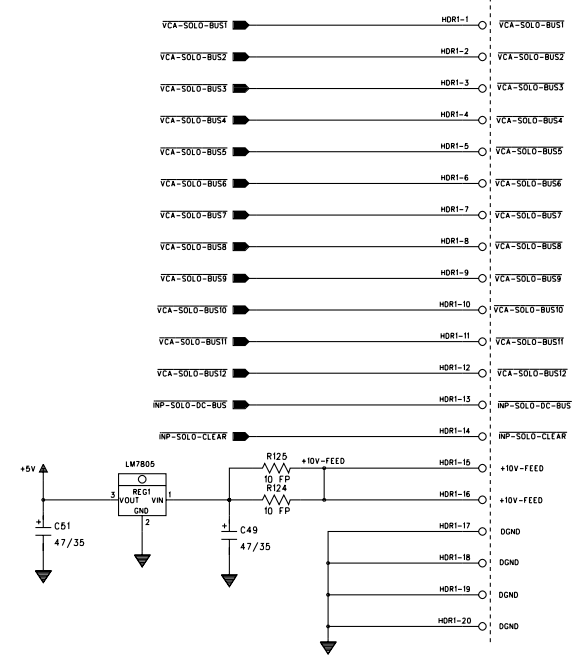

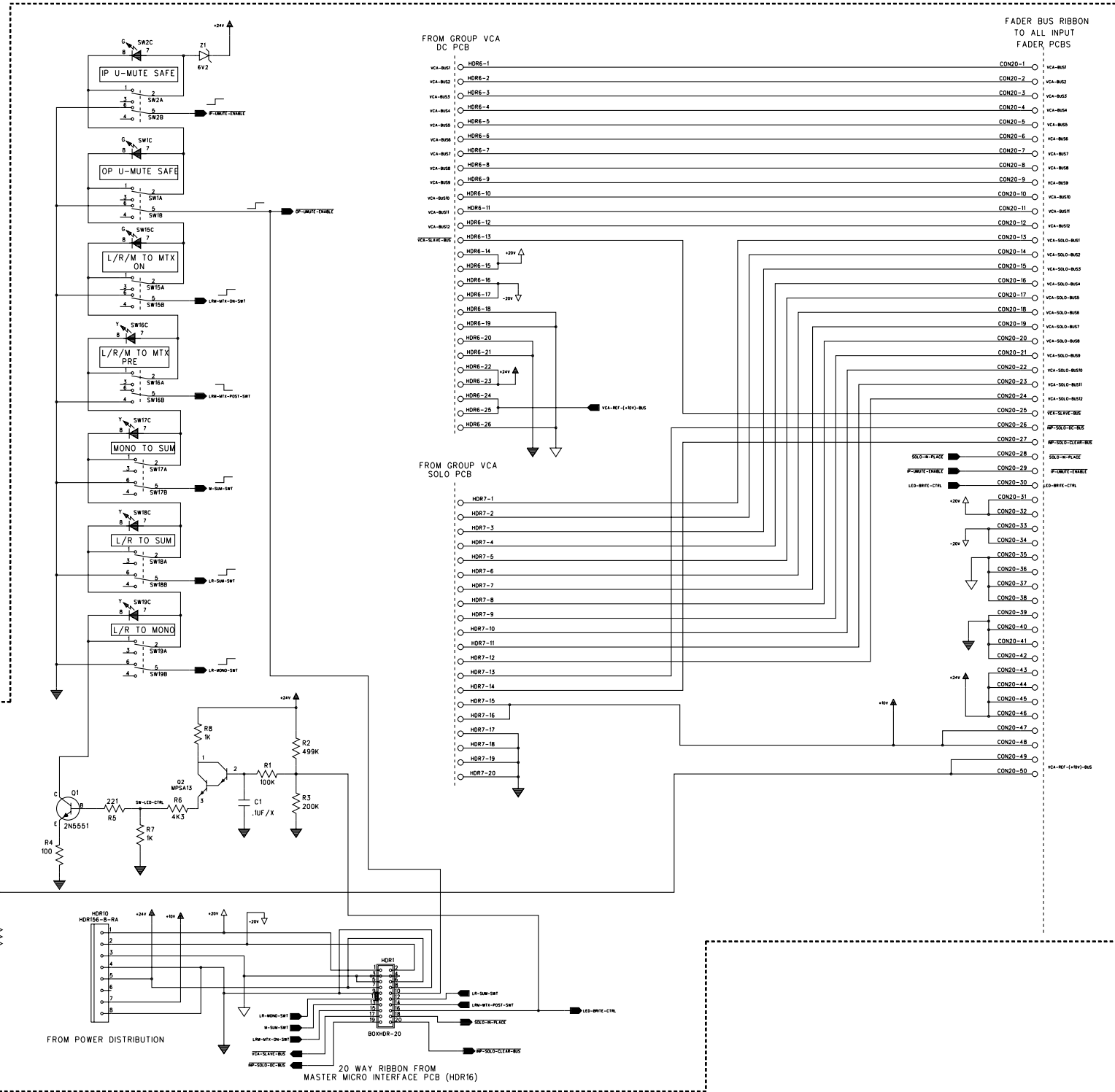
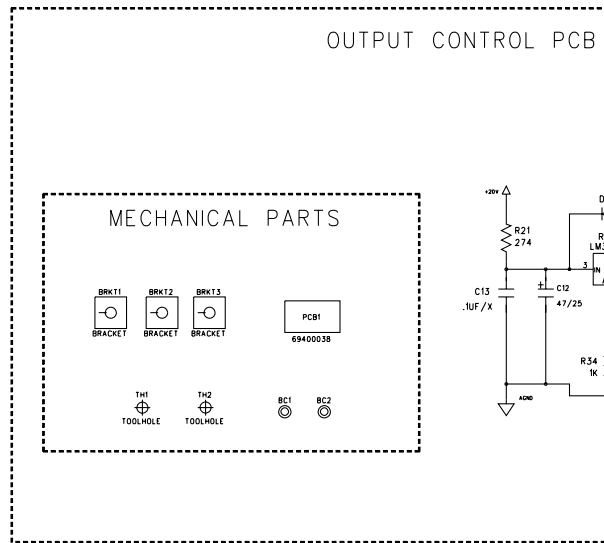
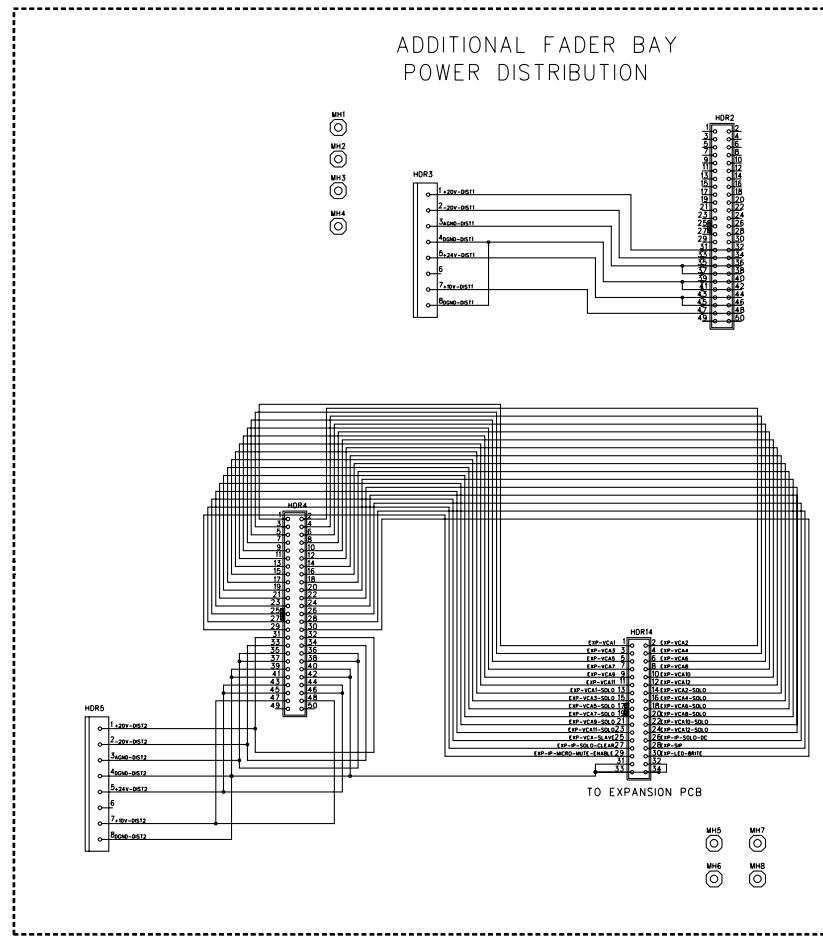

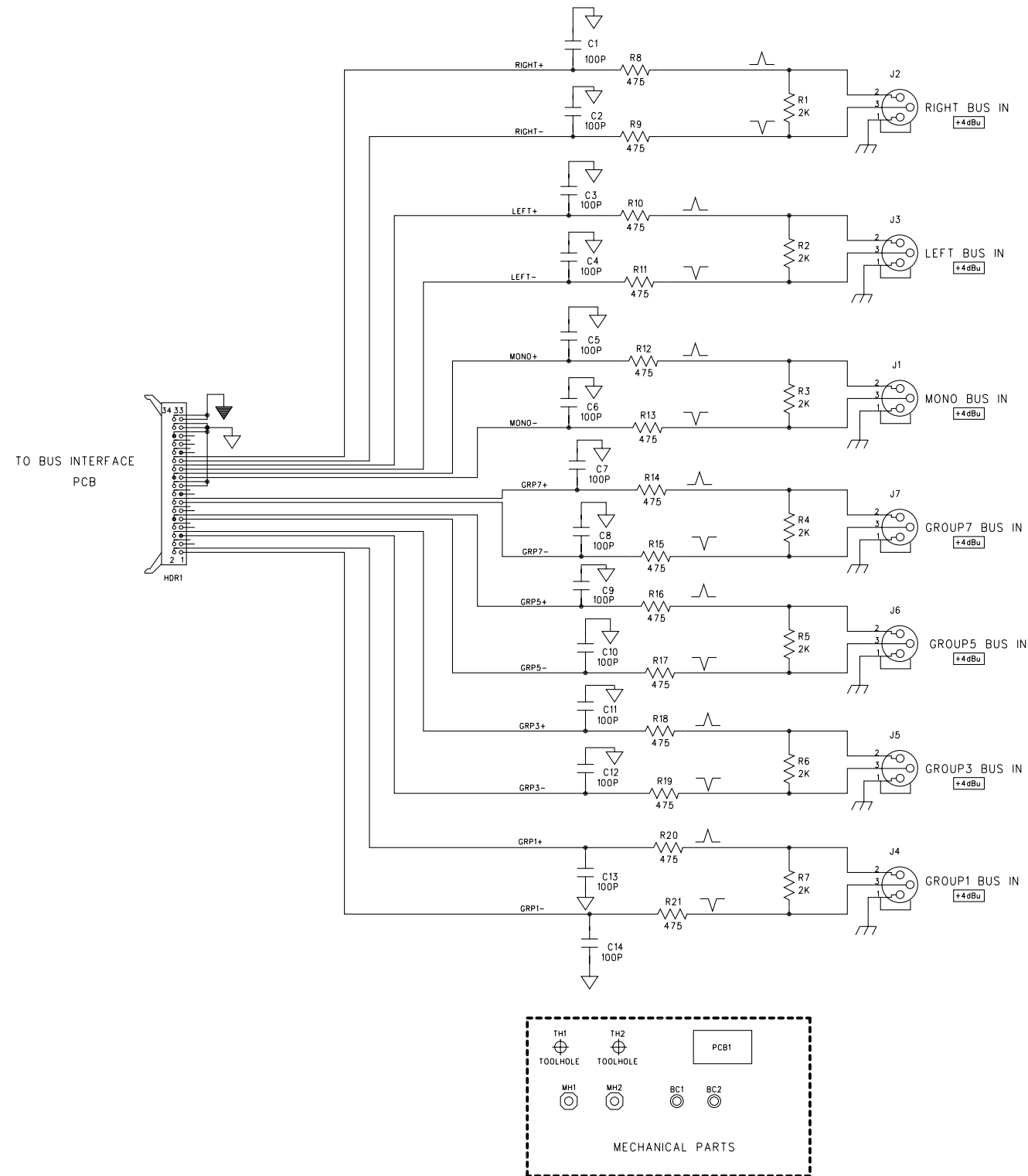

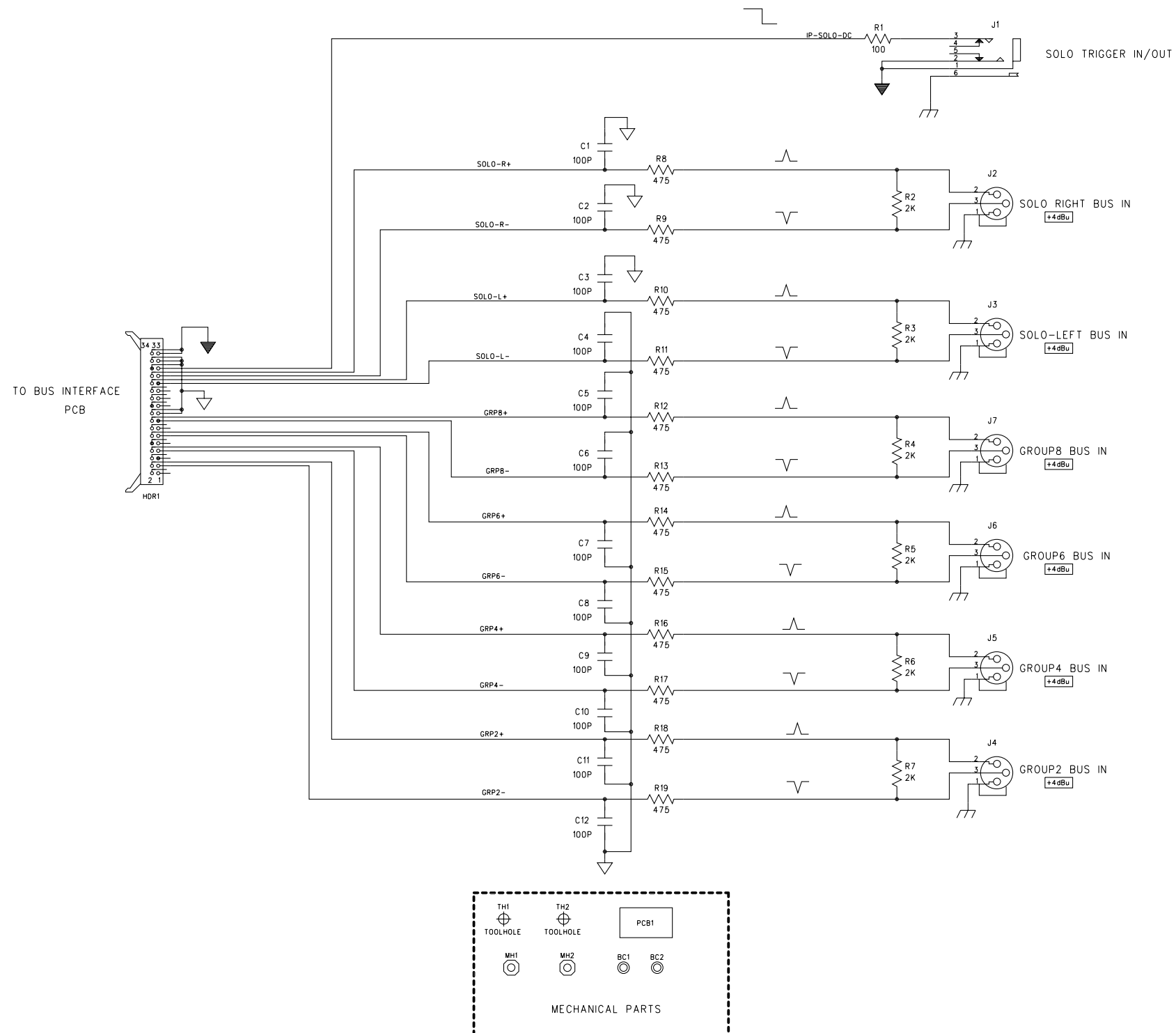

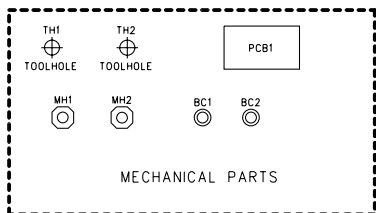
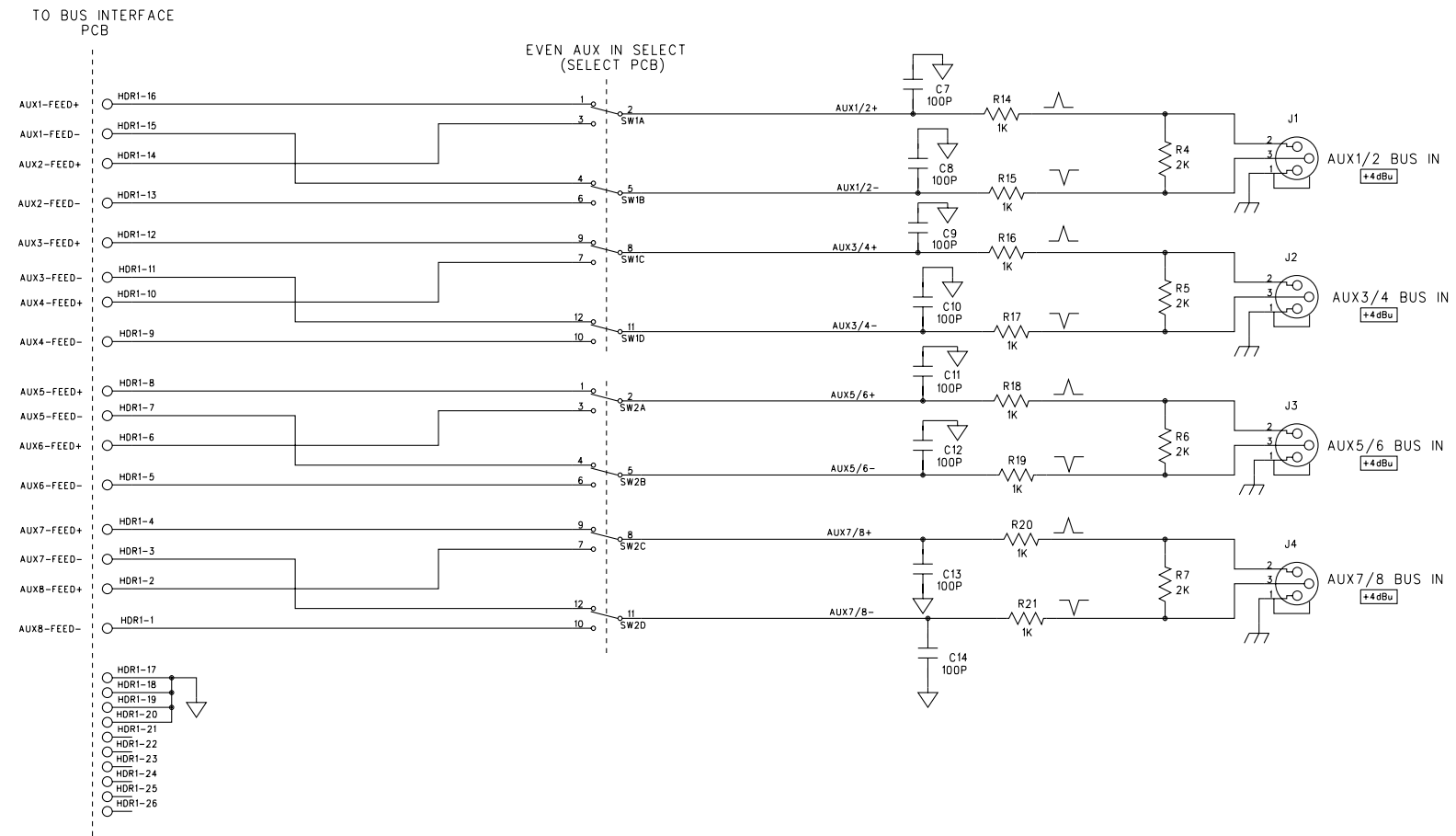

16 WAY EXTERNAL MATRIX RIBBON TO MASTER MOTHERBOARD HDR1

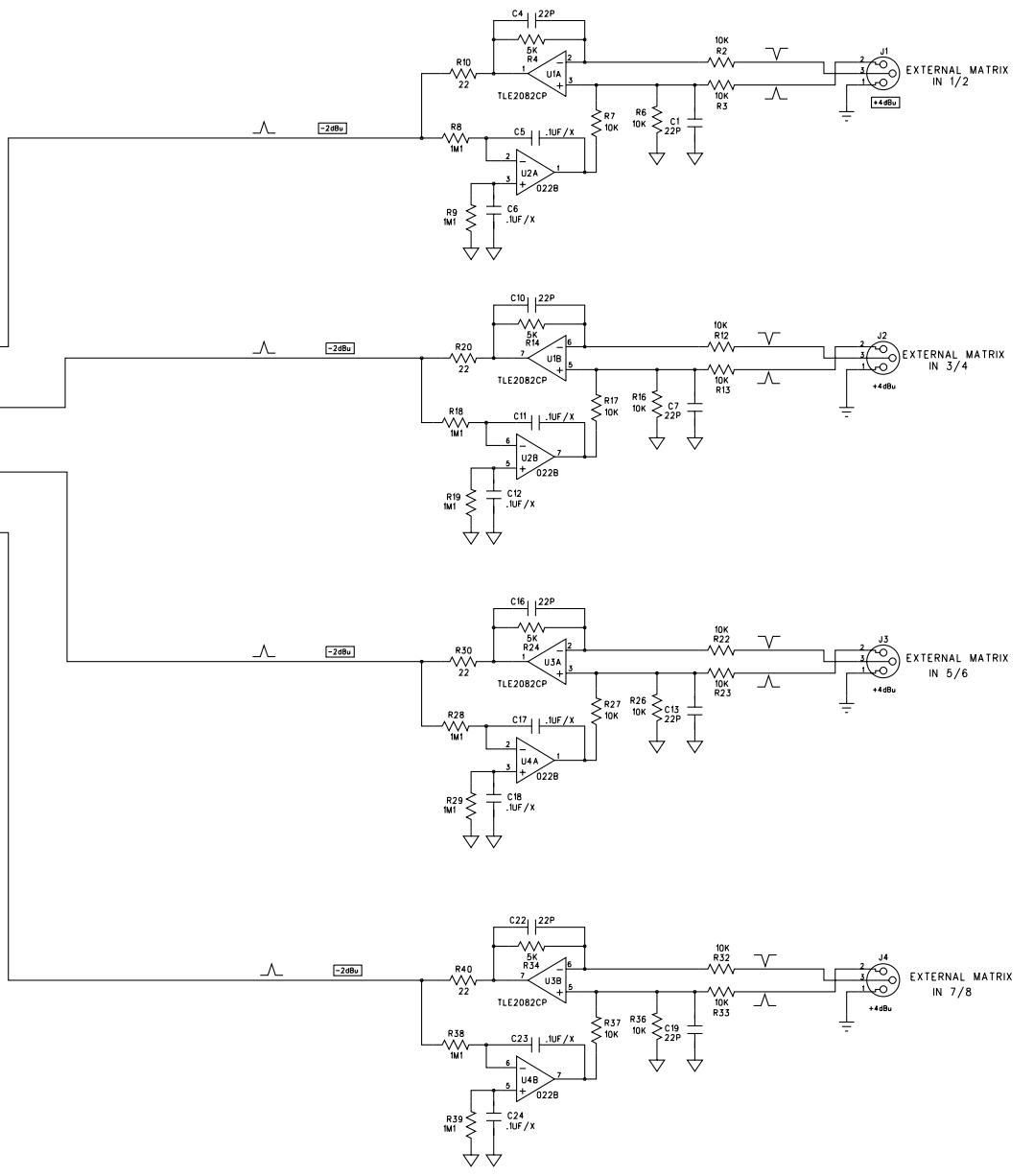
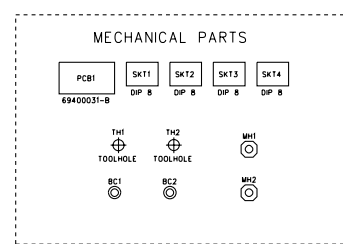
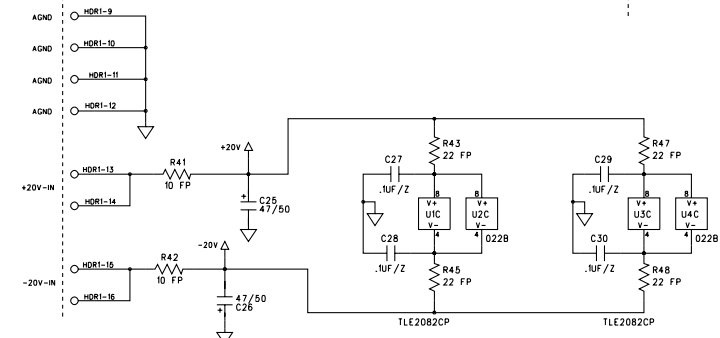
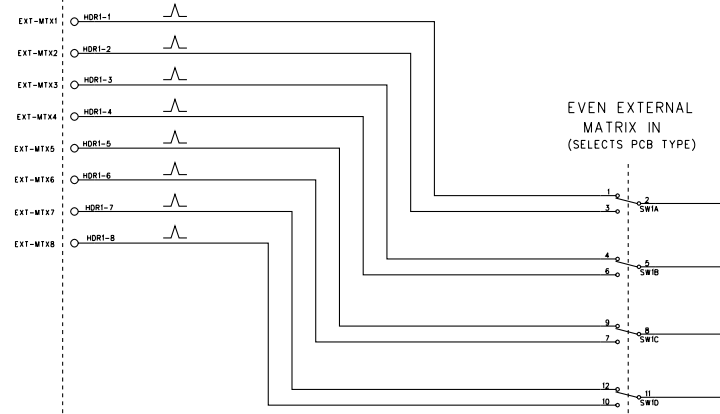

26 WAY OUTPUT MODULE
INTERFACE PCB TO MASTER
MOTHERBOARD HDR2/HDR3/HDR4/HDR5

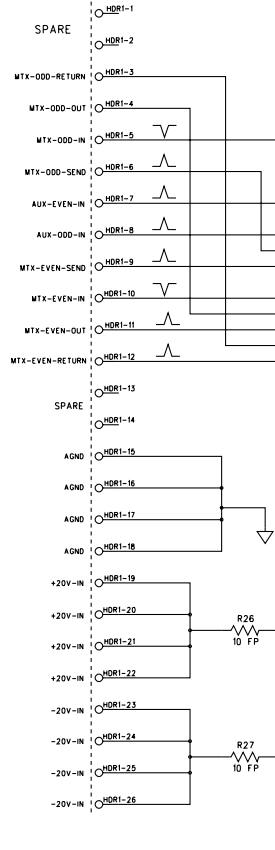

EVEN IN/OUT
(SELECT PCB TYPE)

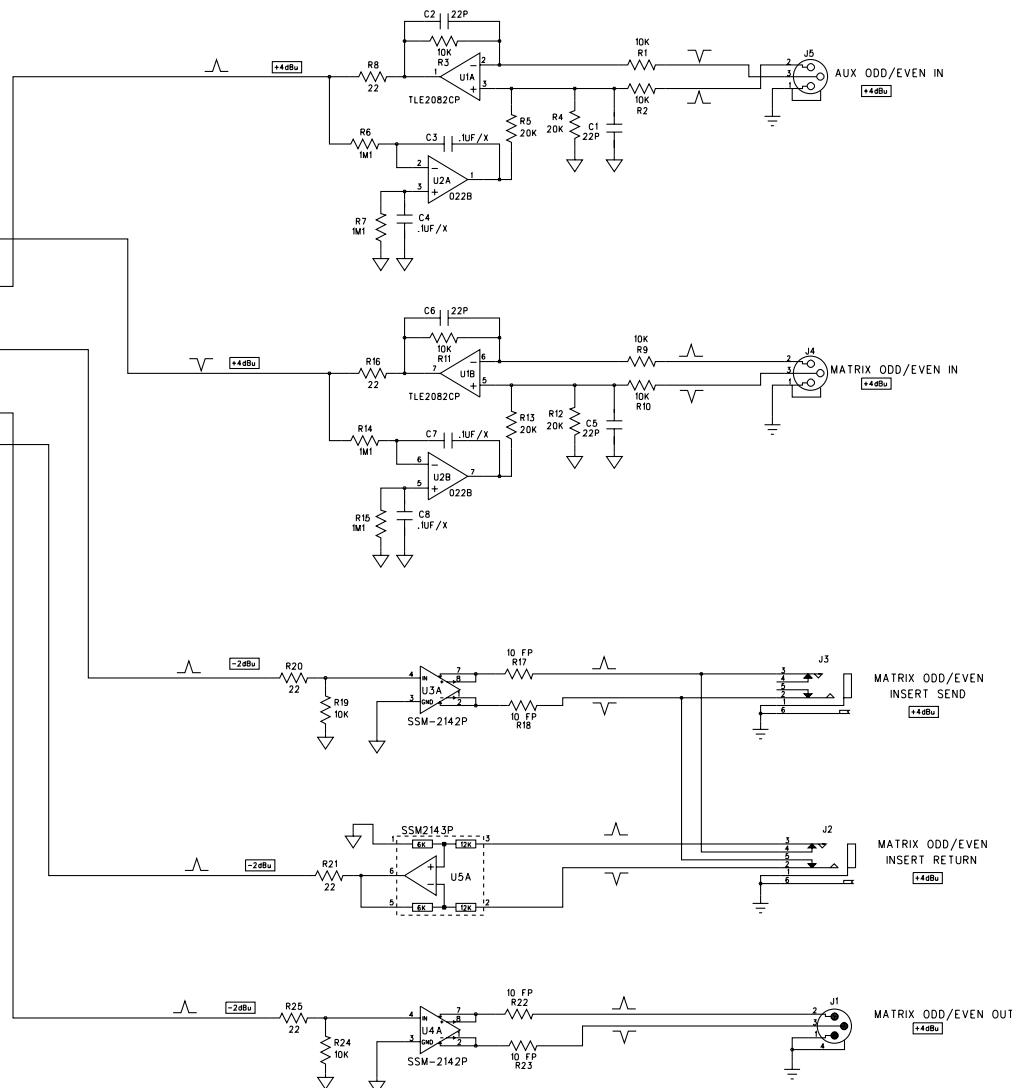
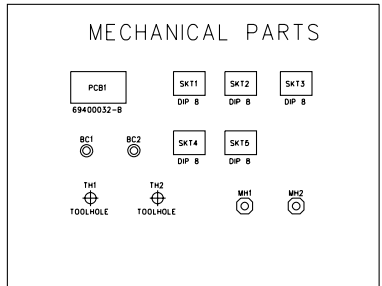
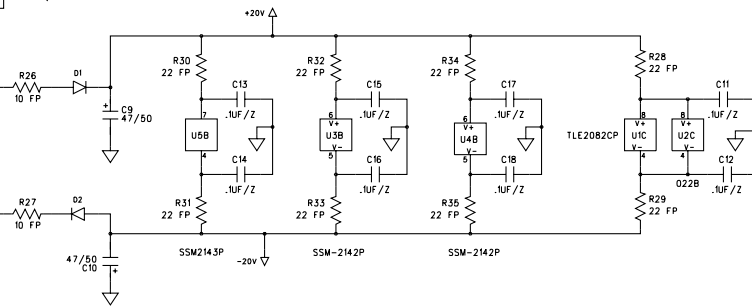
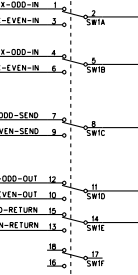

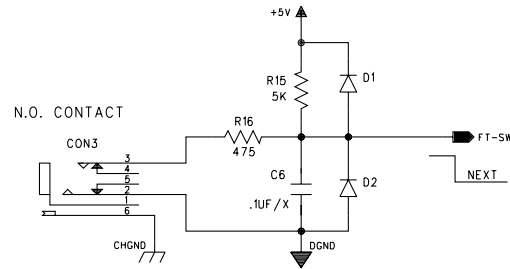
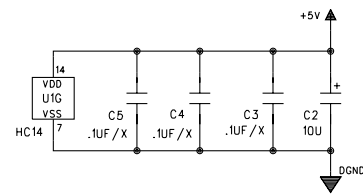

TO FOOTSW- EXT GO/NEXT

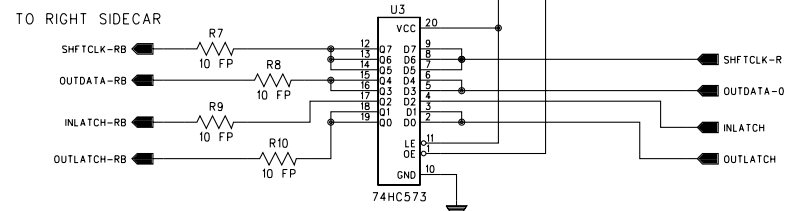
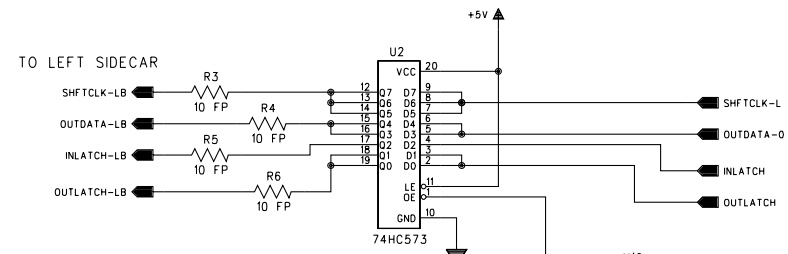

CABLE DRIVERS TO LEFT & RIGHT SIDECARS

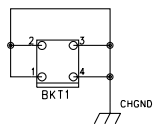
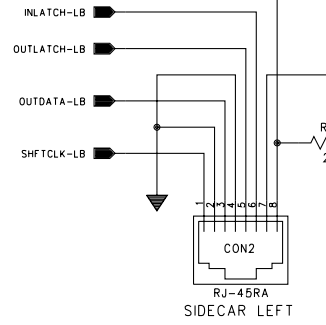
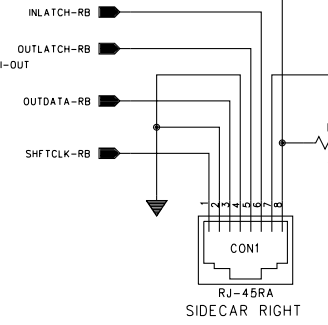
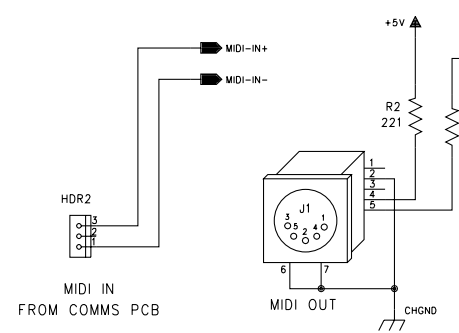
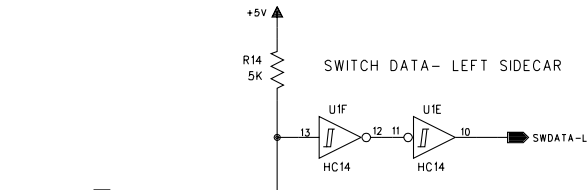
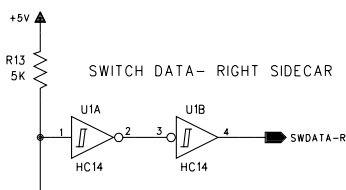
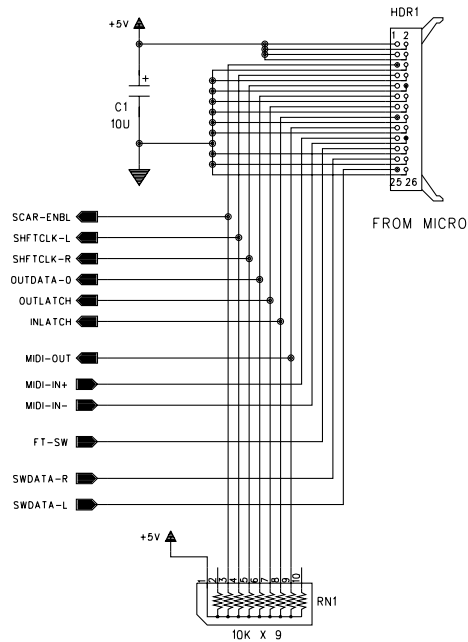

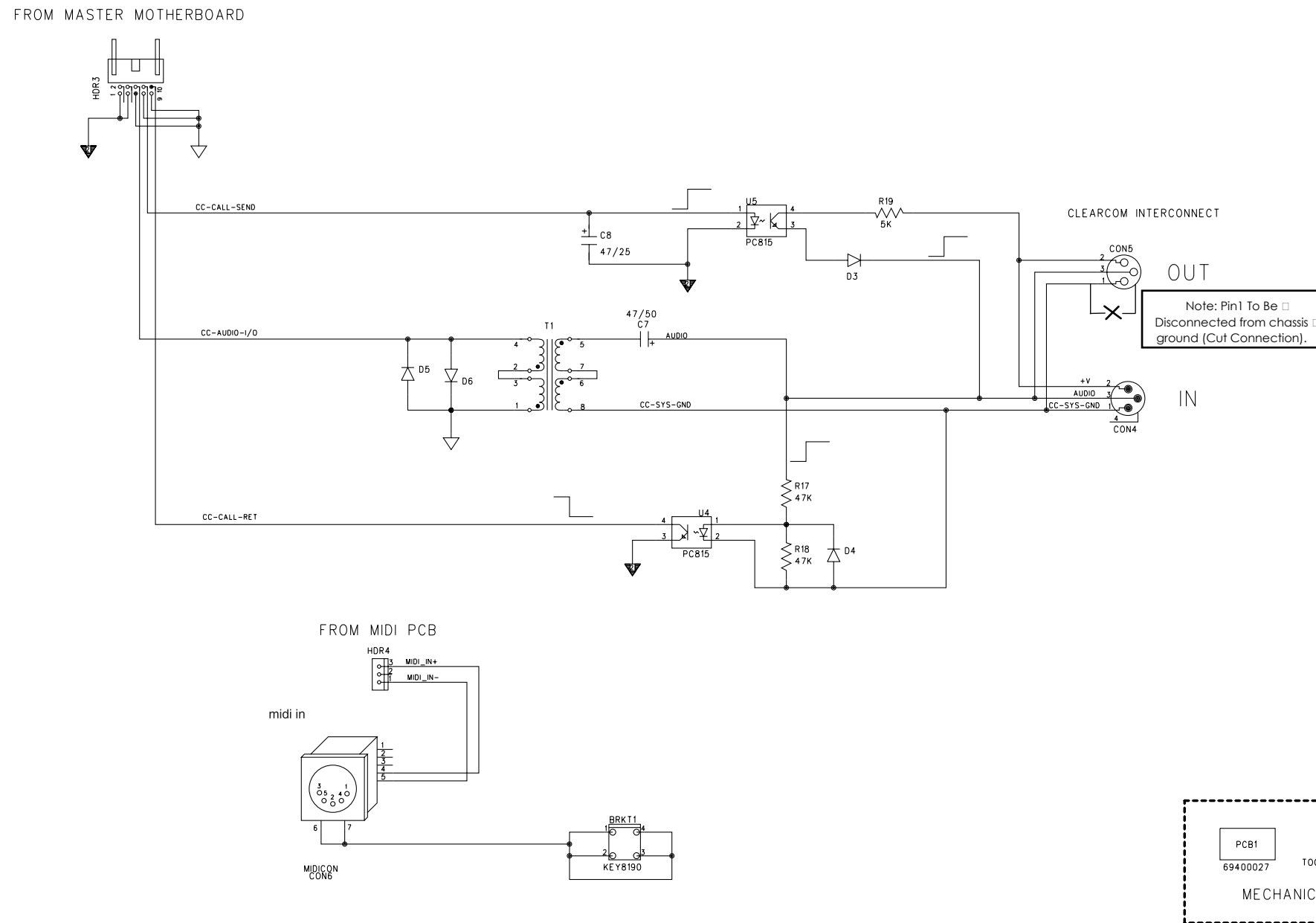

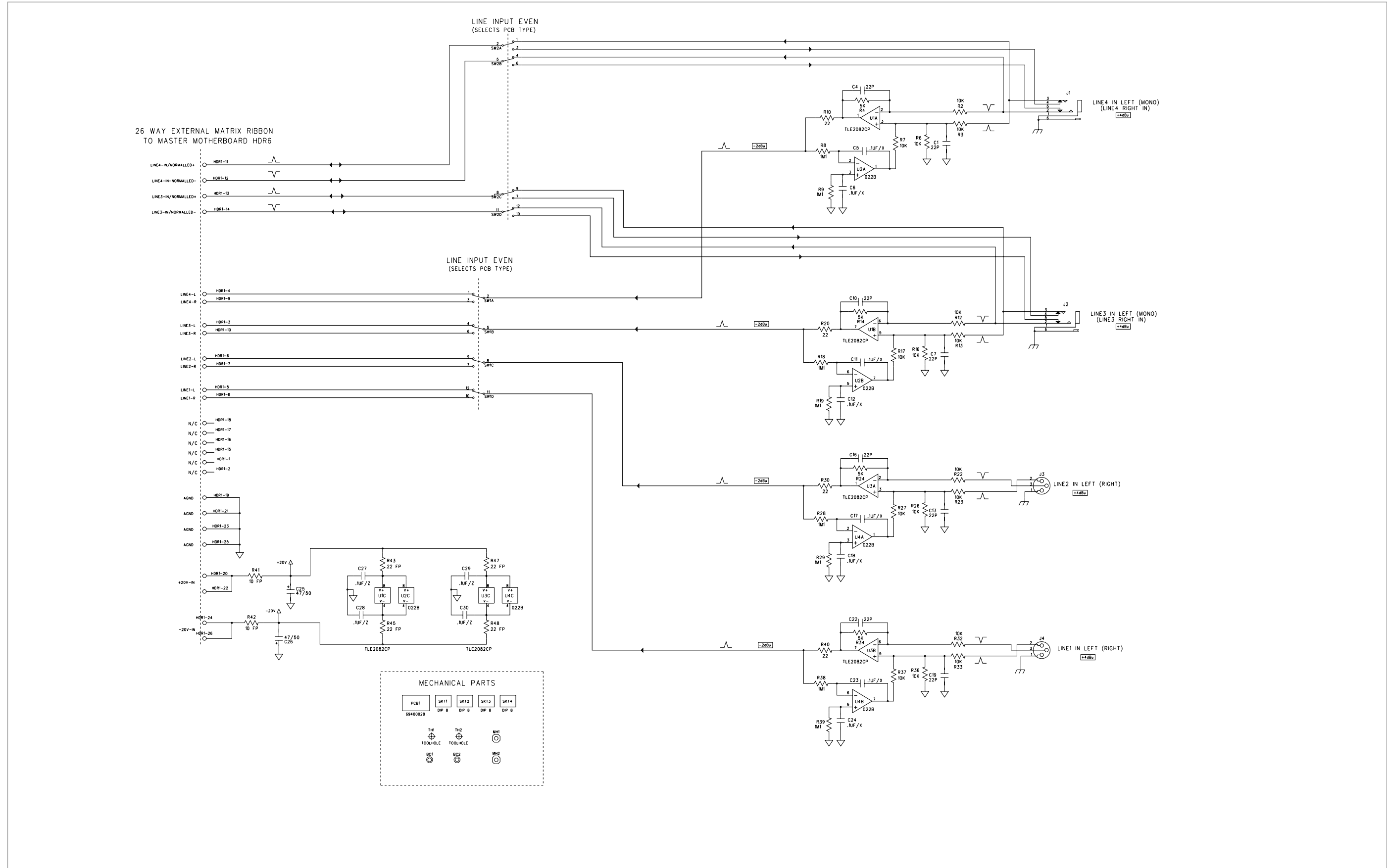

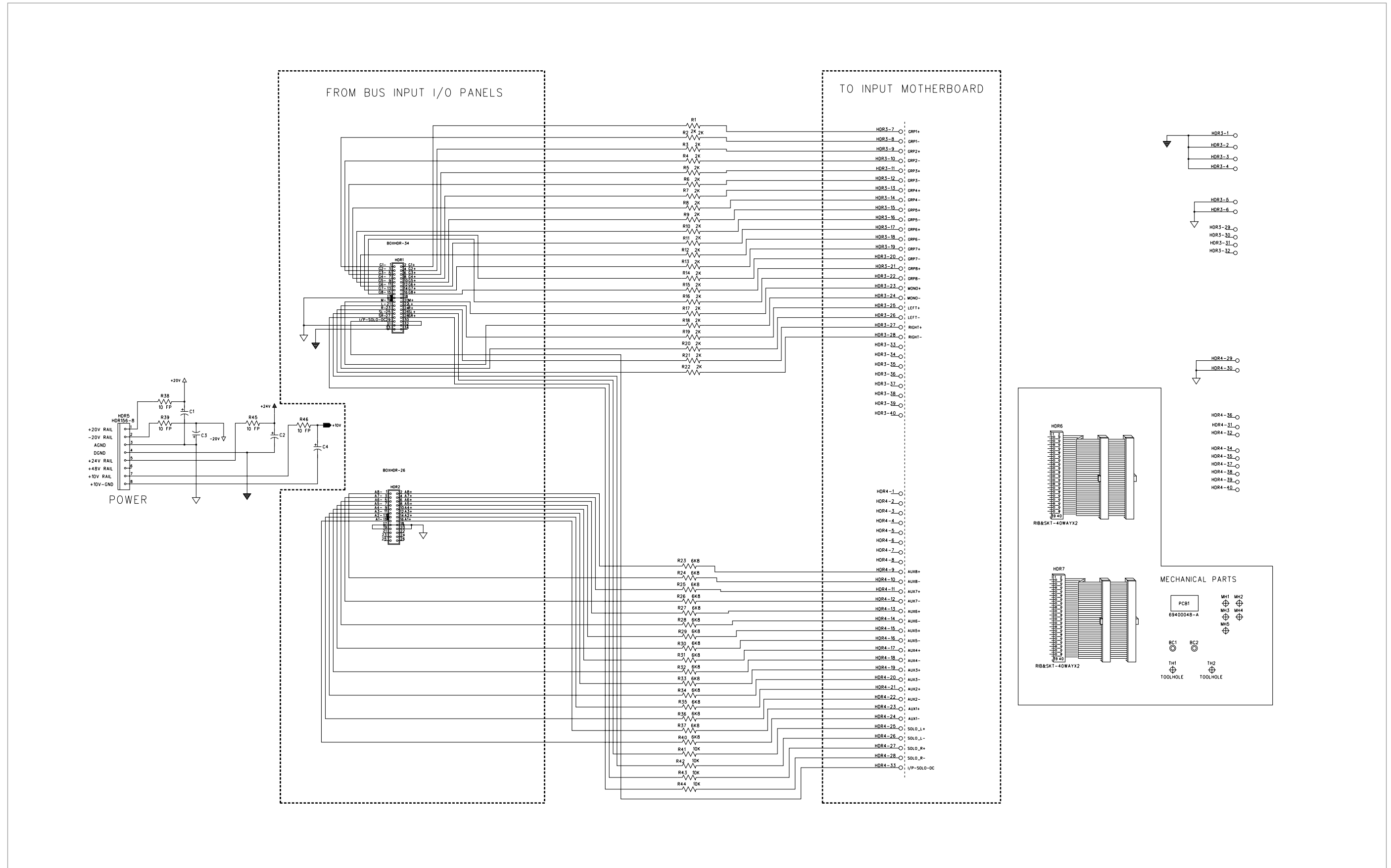

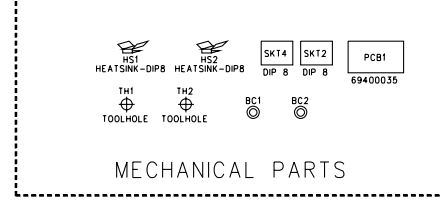
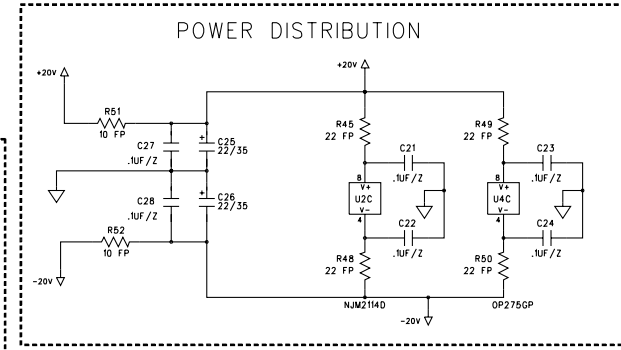
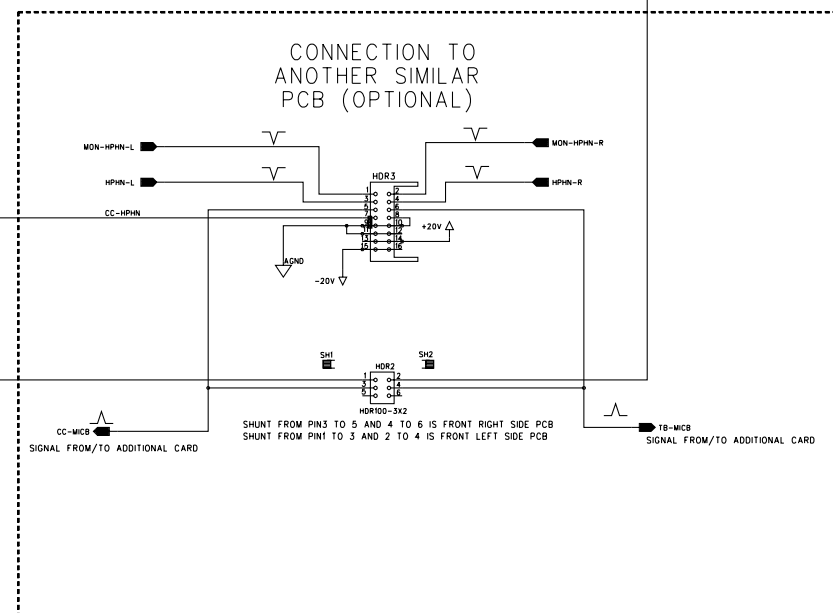
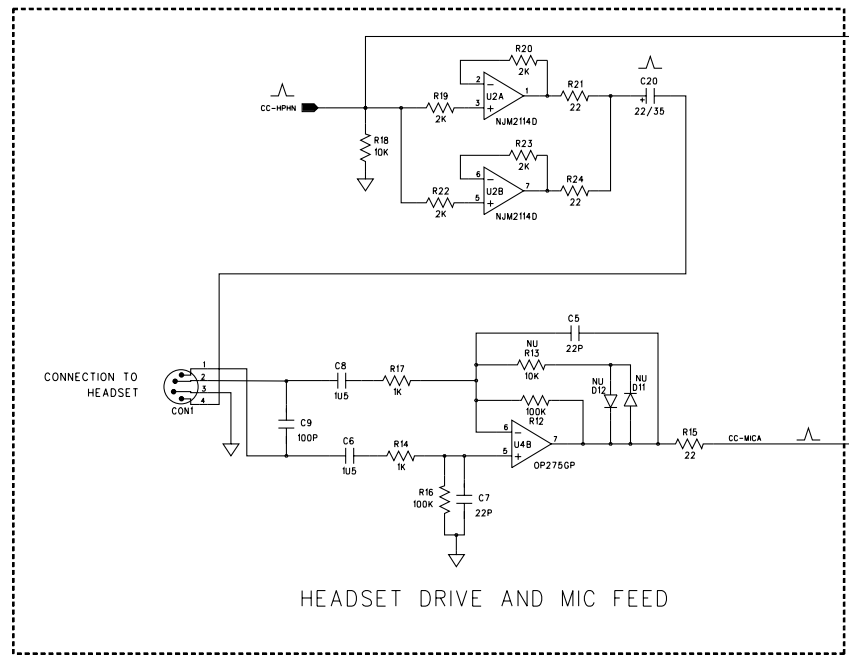
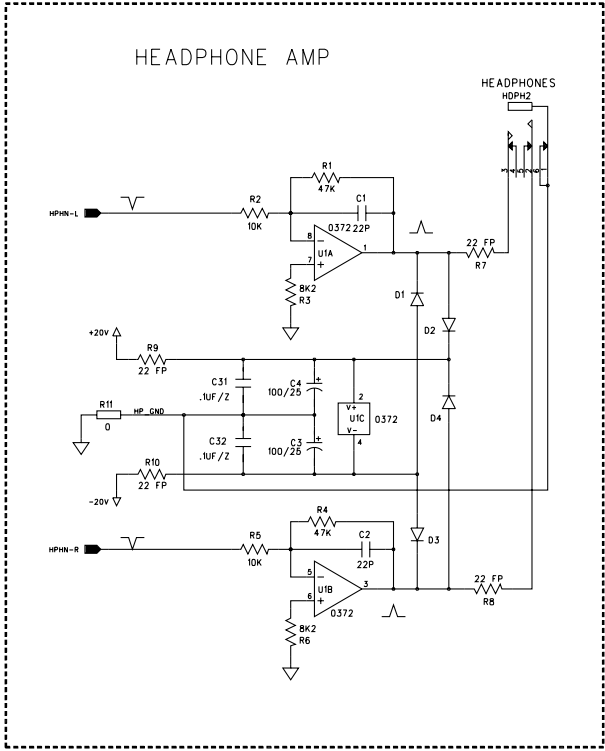
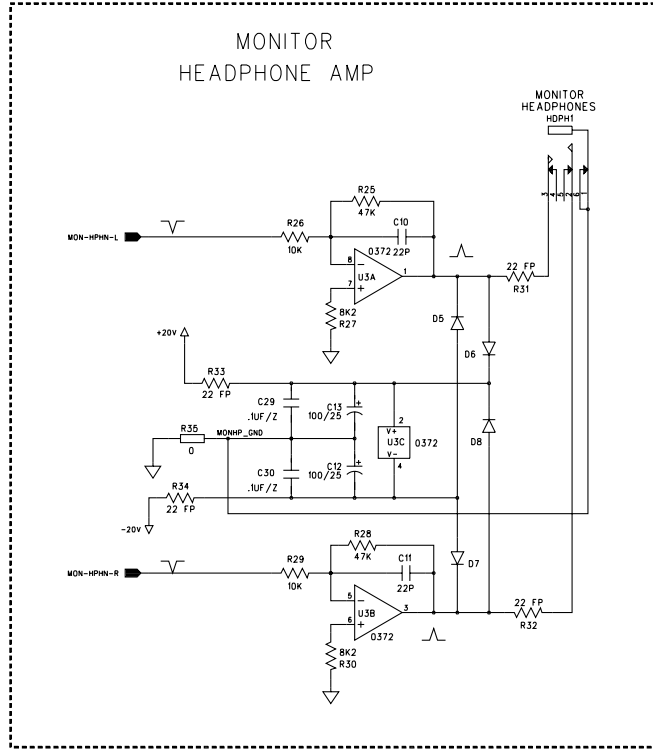
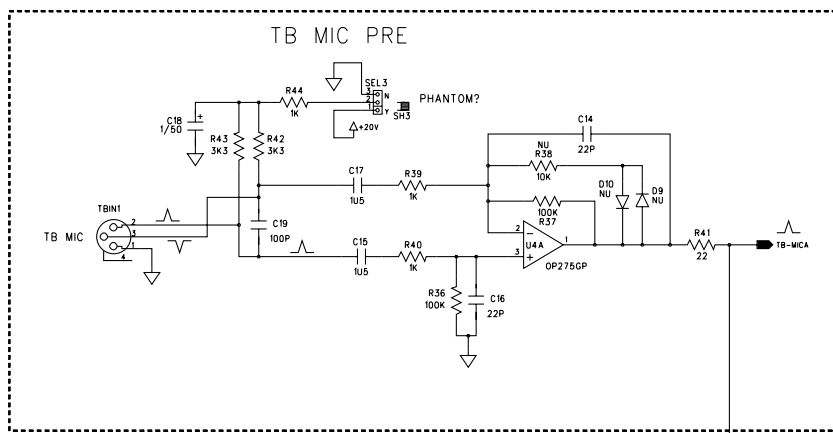
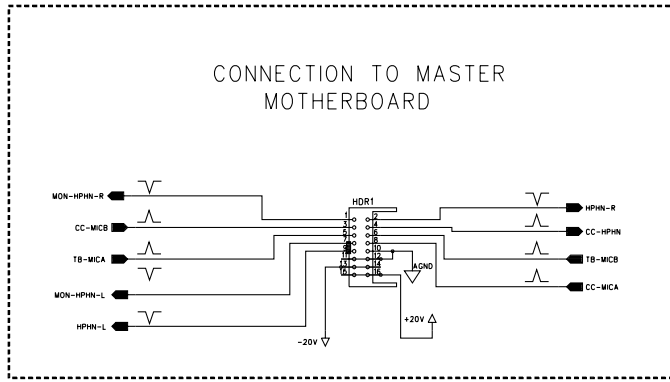

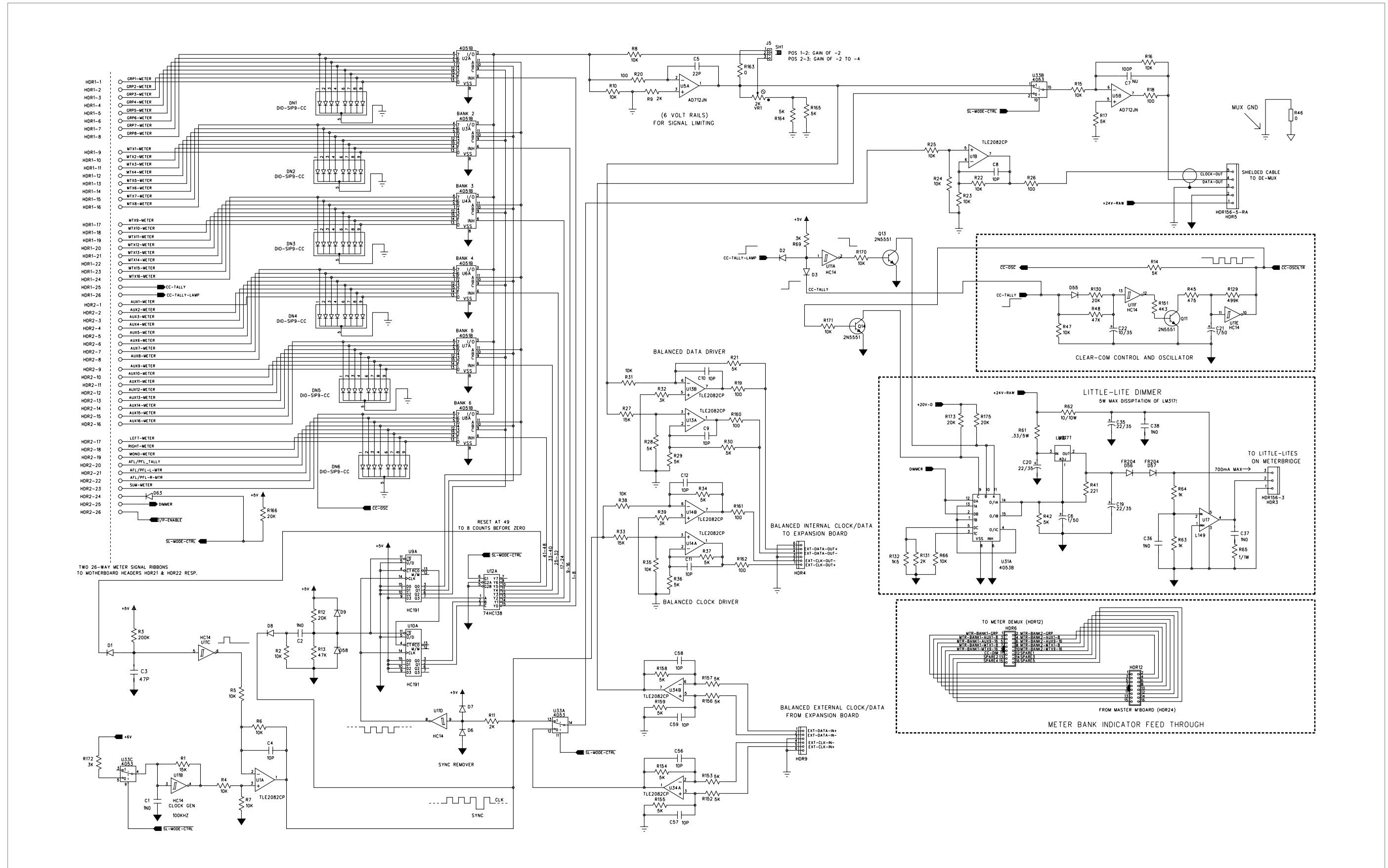

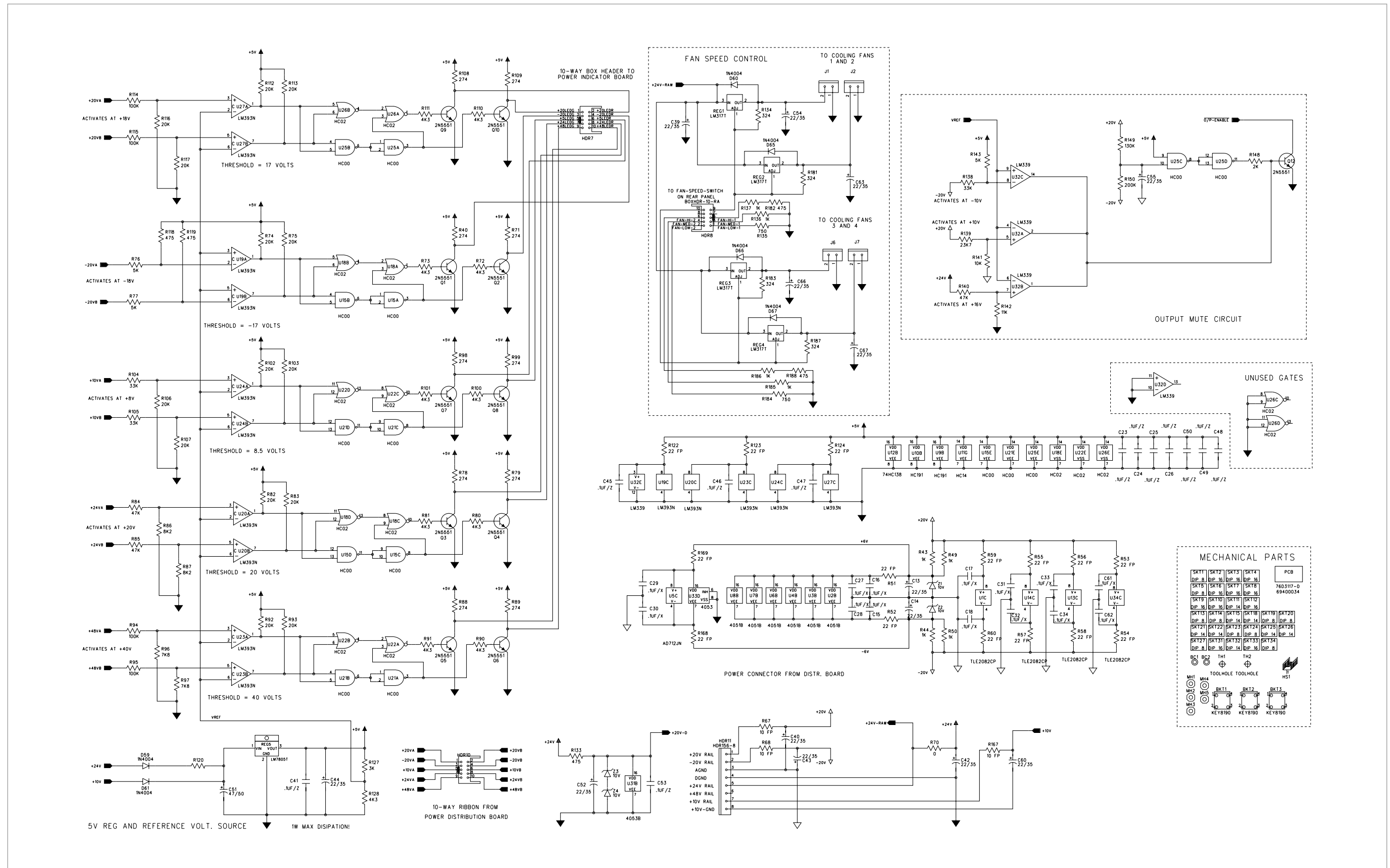

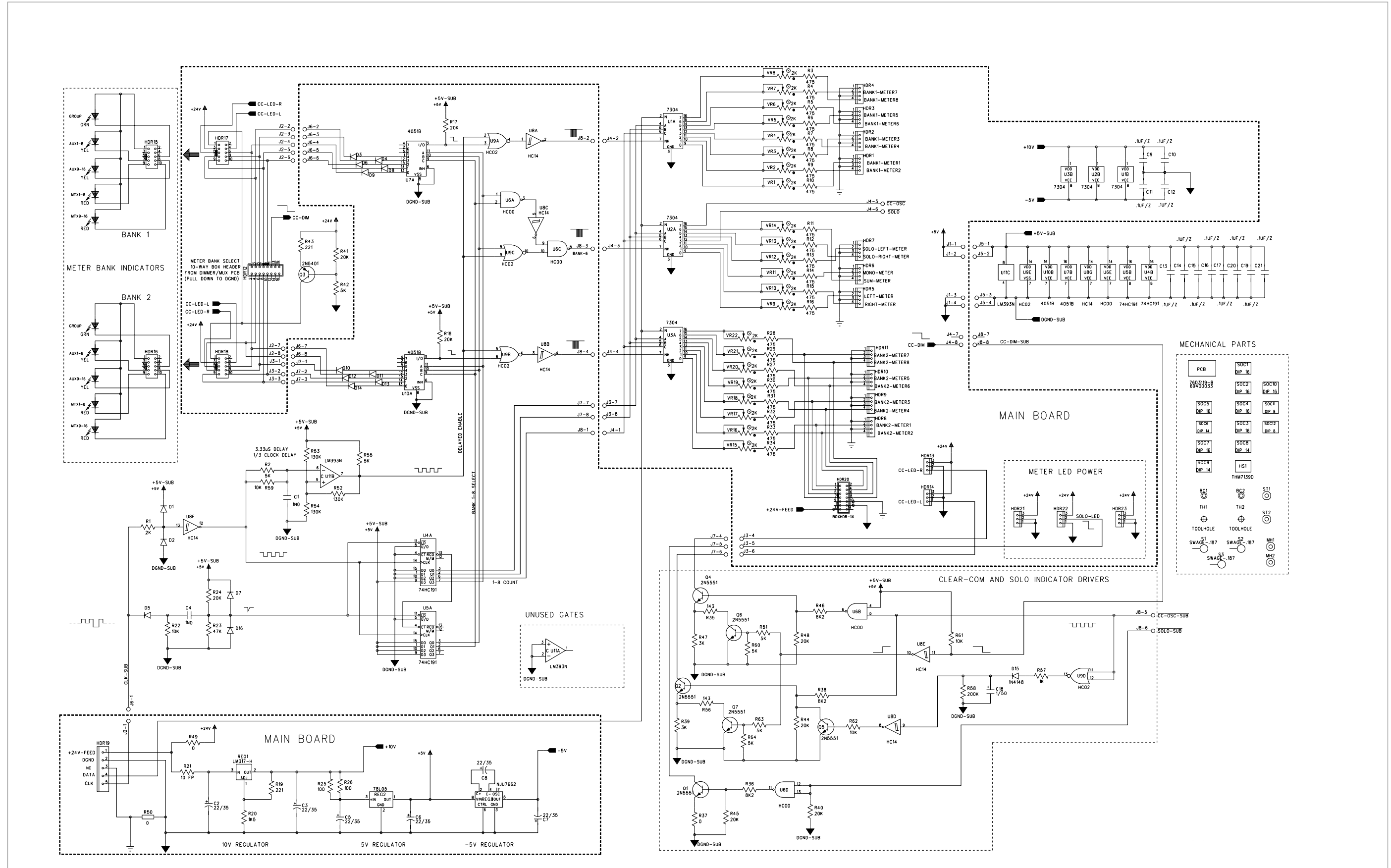

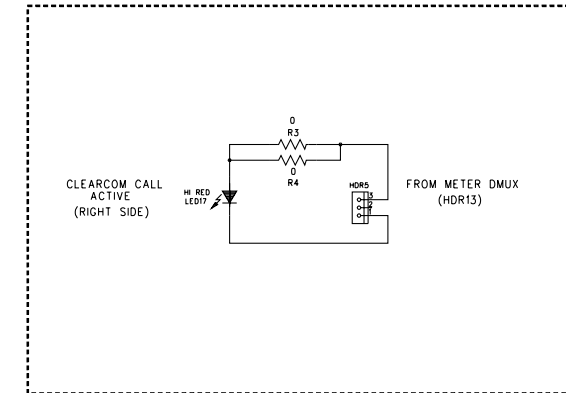
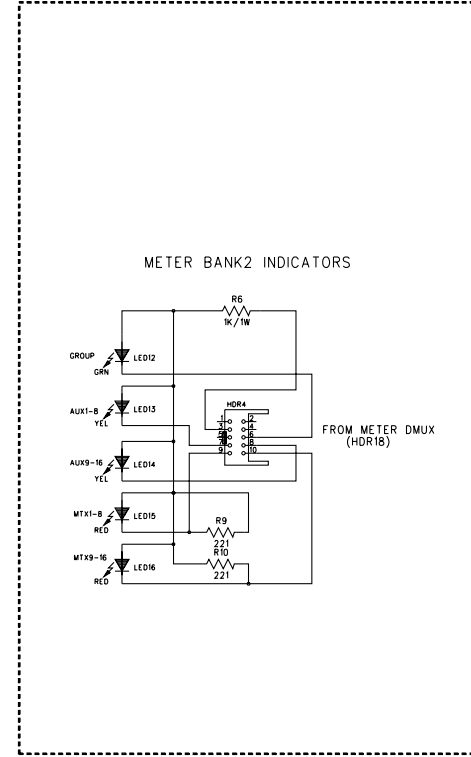
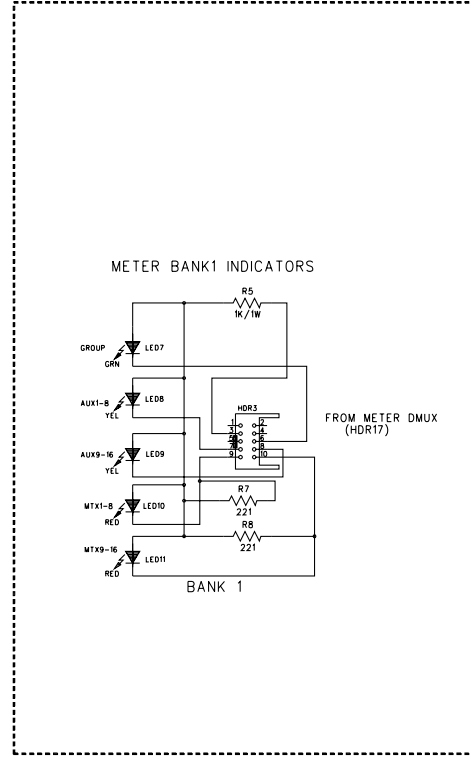
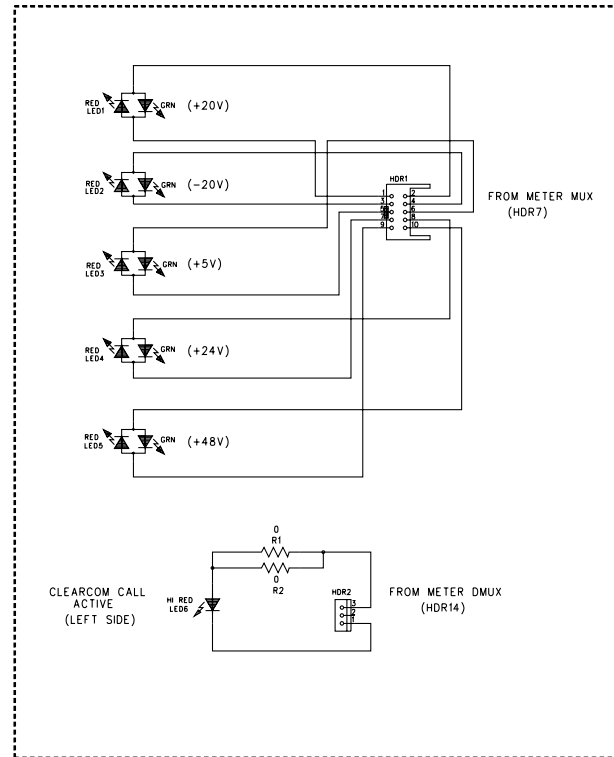

REVISION RECORD					
REV LEVEL	ASMBLY LEVEL	DATE	DCO	ENG.	DESCRIPTION
B	A	2/4/99	886	TAZ	REVA TO REV B CHANGE. TO HAVE THE METER BANK SELECT DERIVE IT'S CURRENT LOCALLY AND NOT FROM A INSUFFICIENT CURRENT SOURCE LOCATED ON METER DEMUX PCB. ADDED R5 & R6= 1K 1W ADDED R7- R10 = 221R

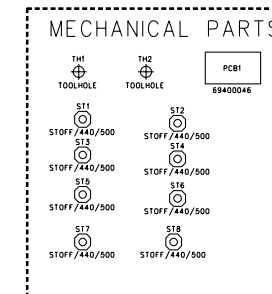

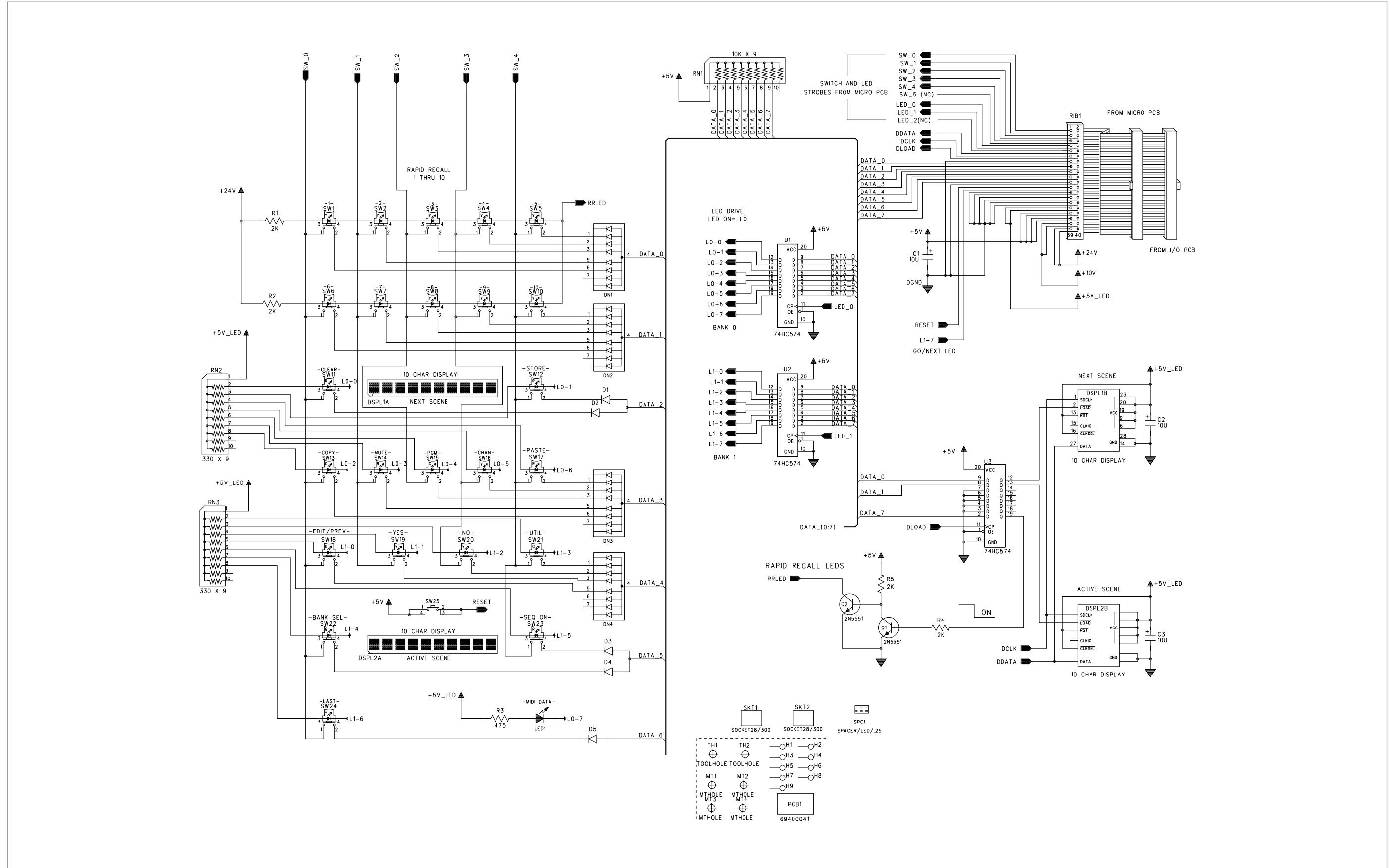

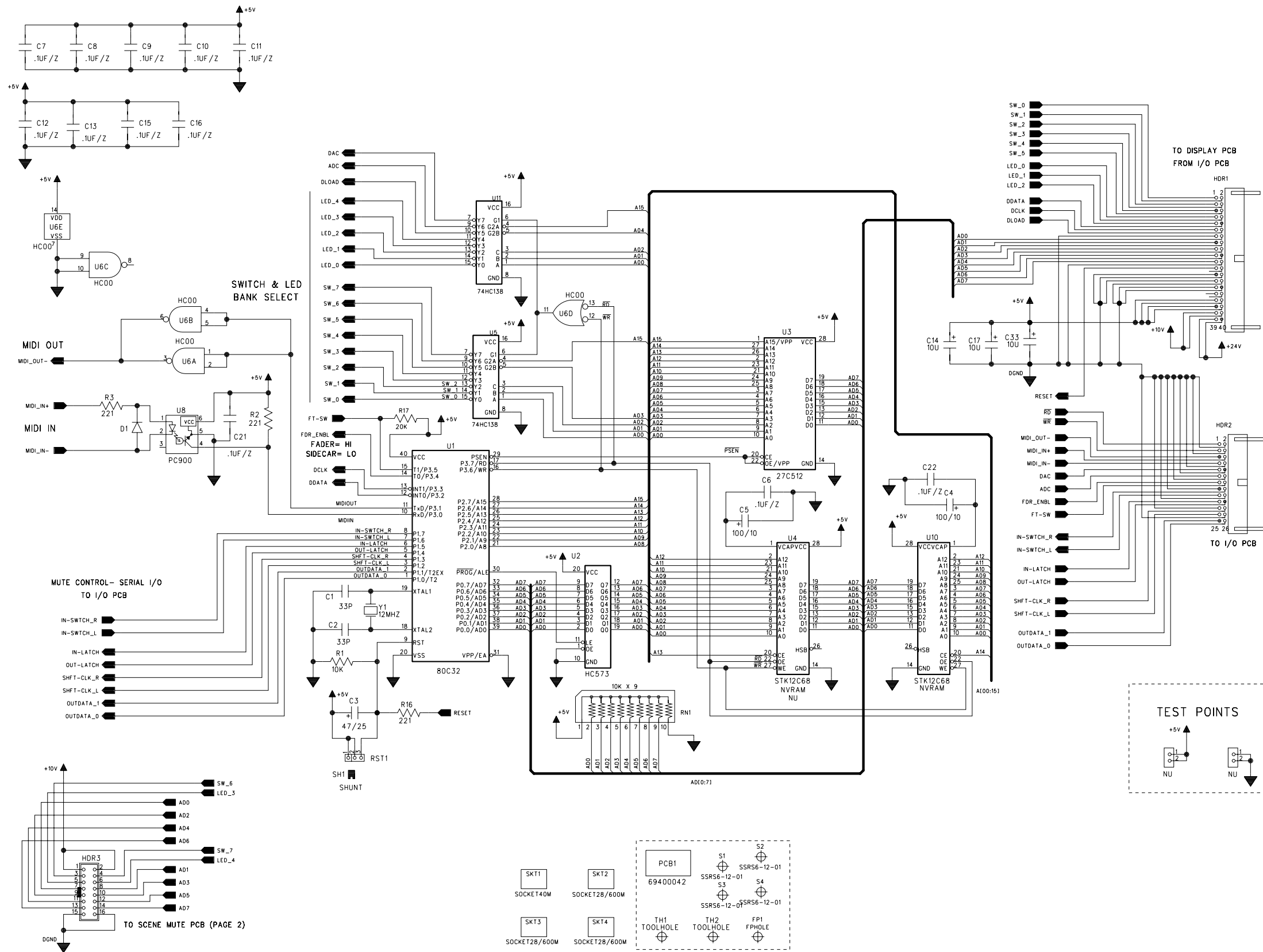

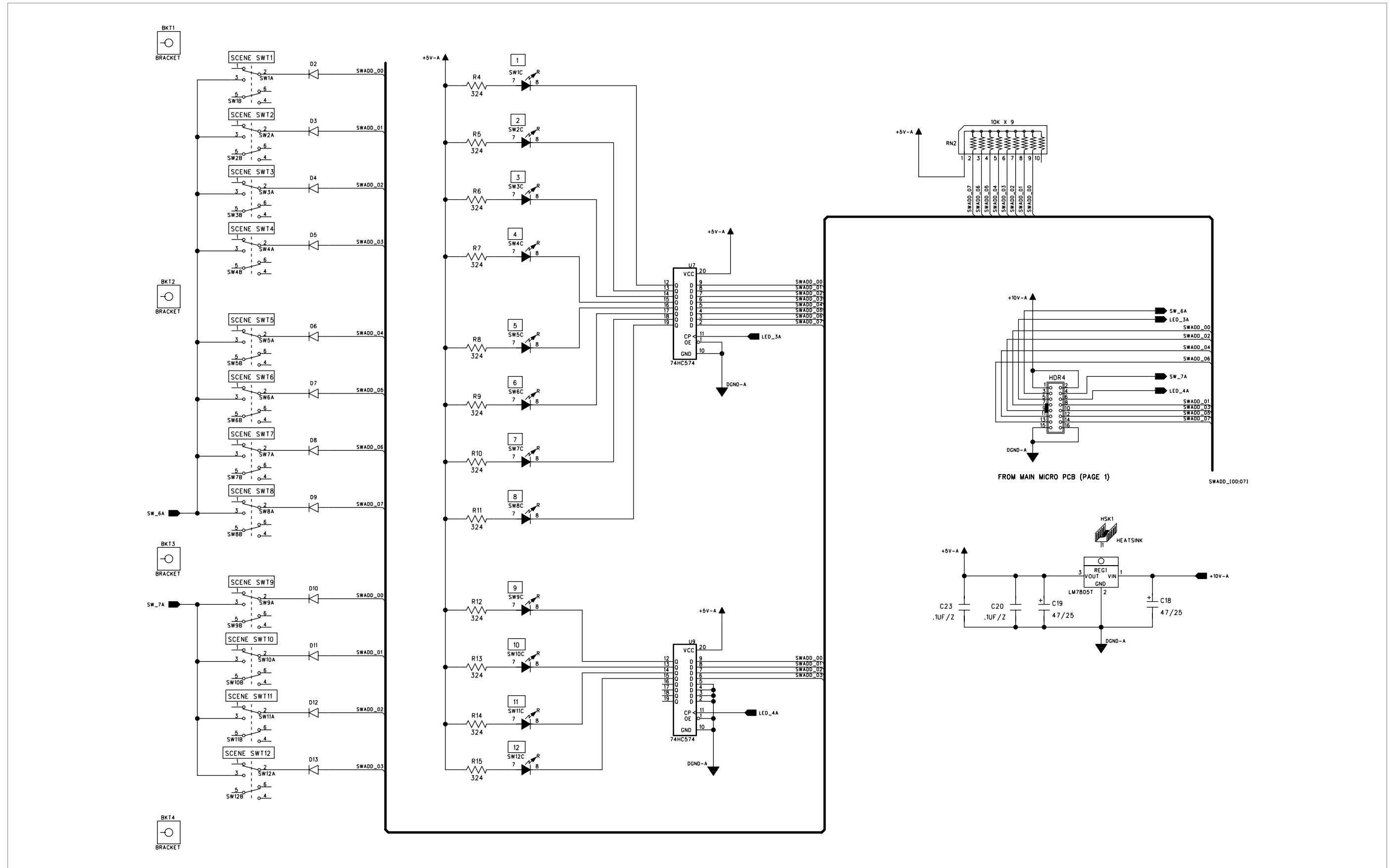

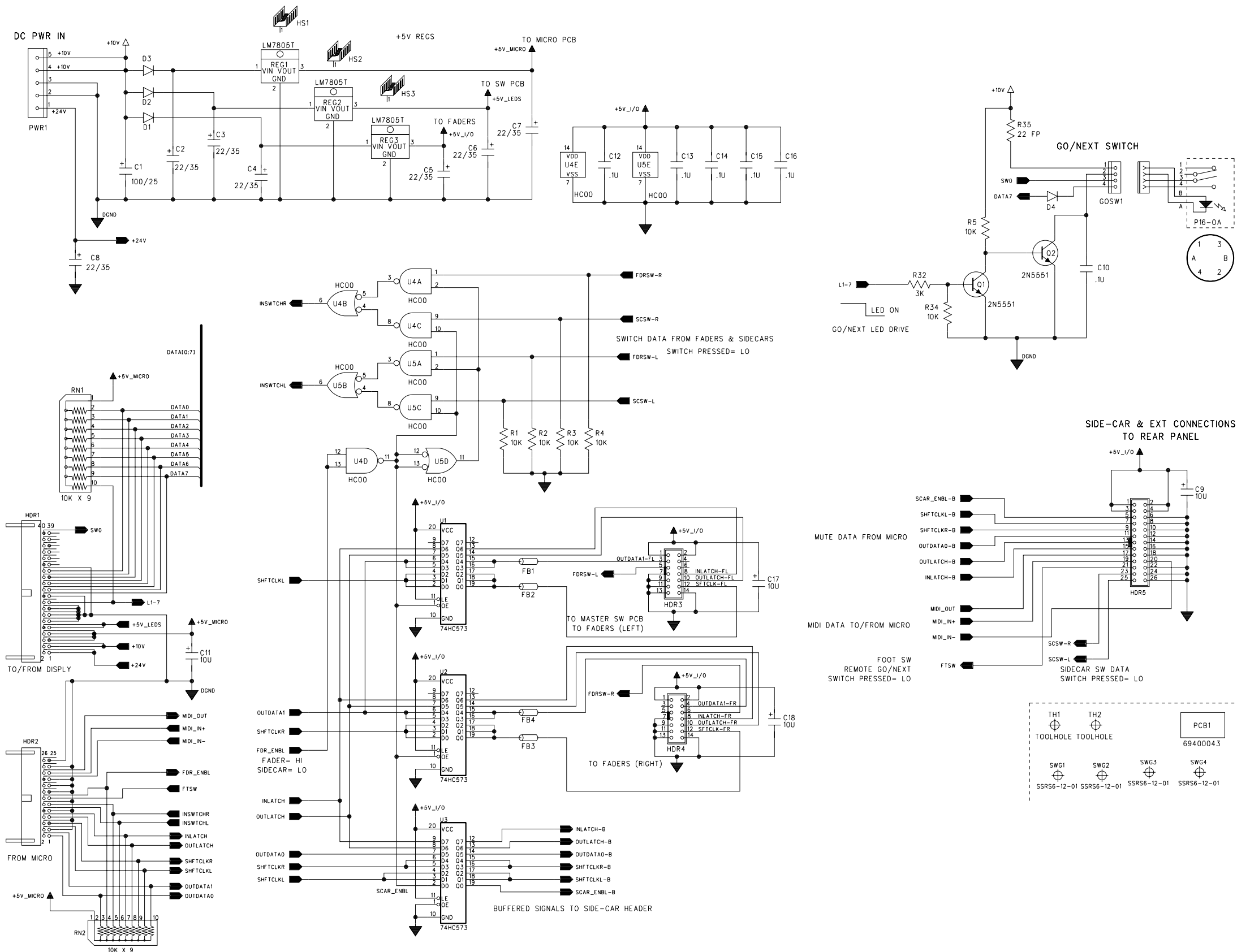

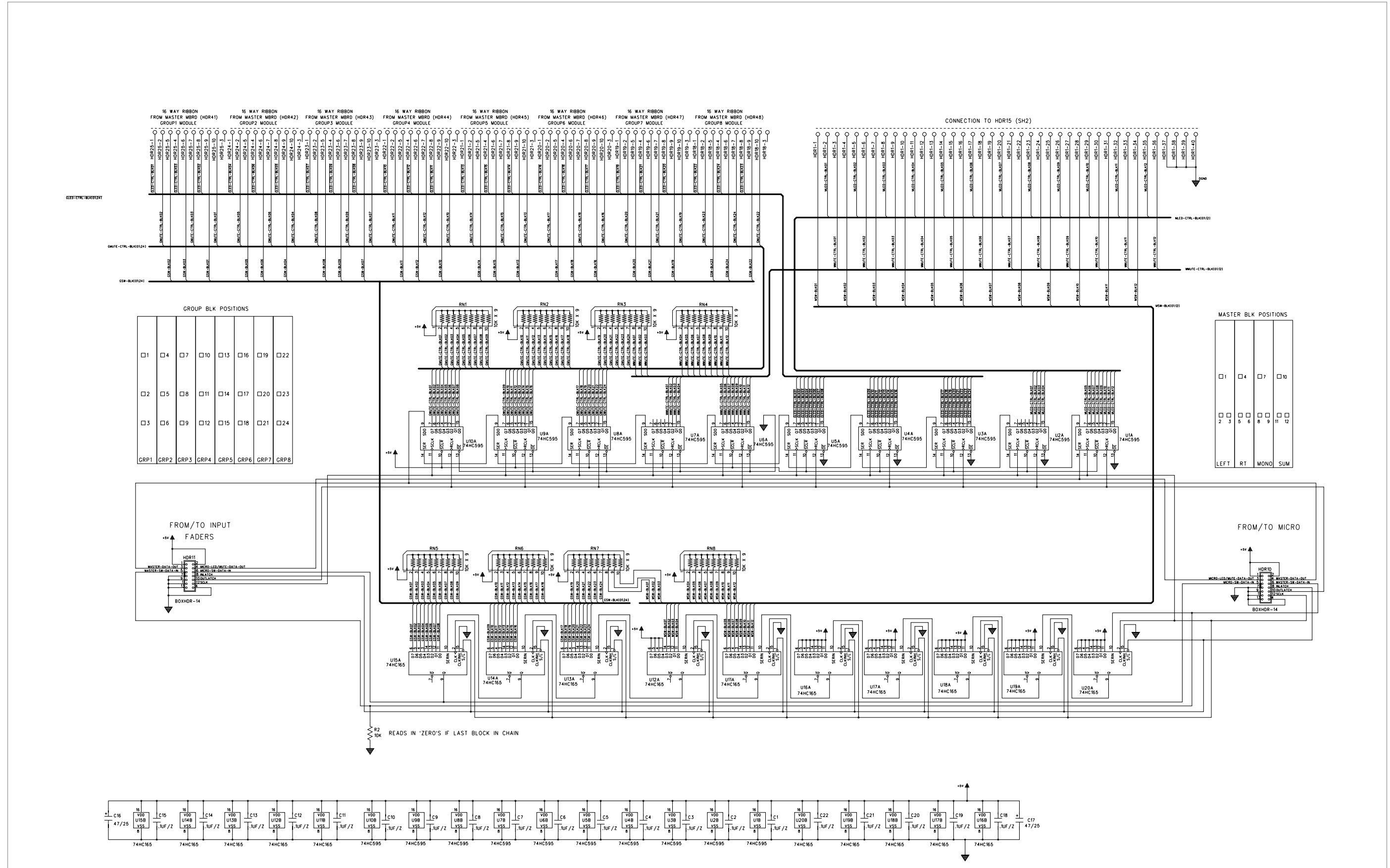

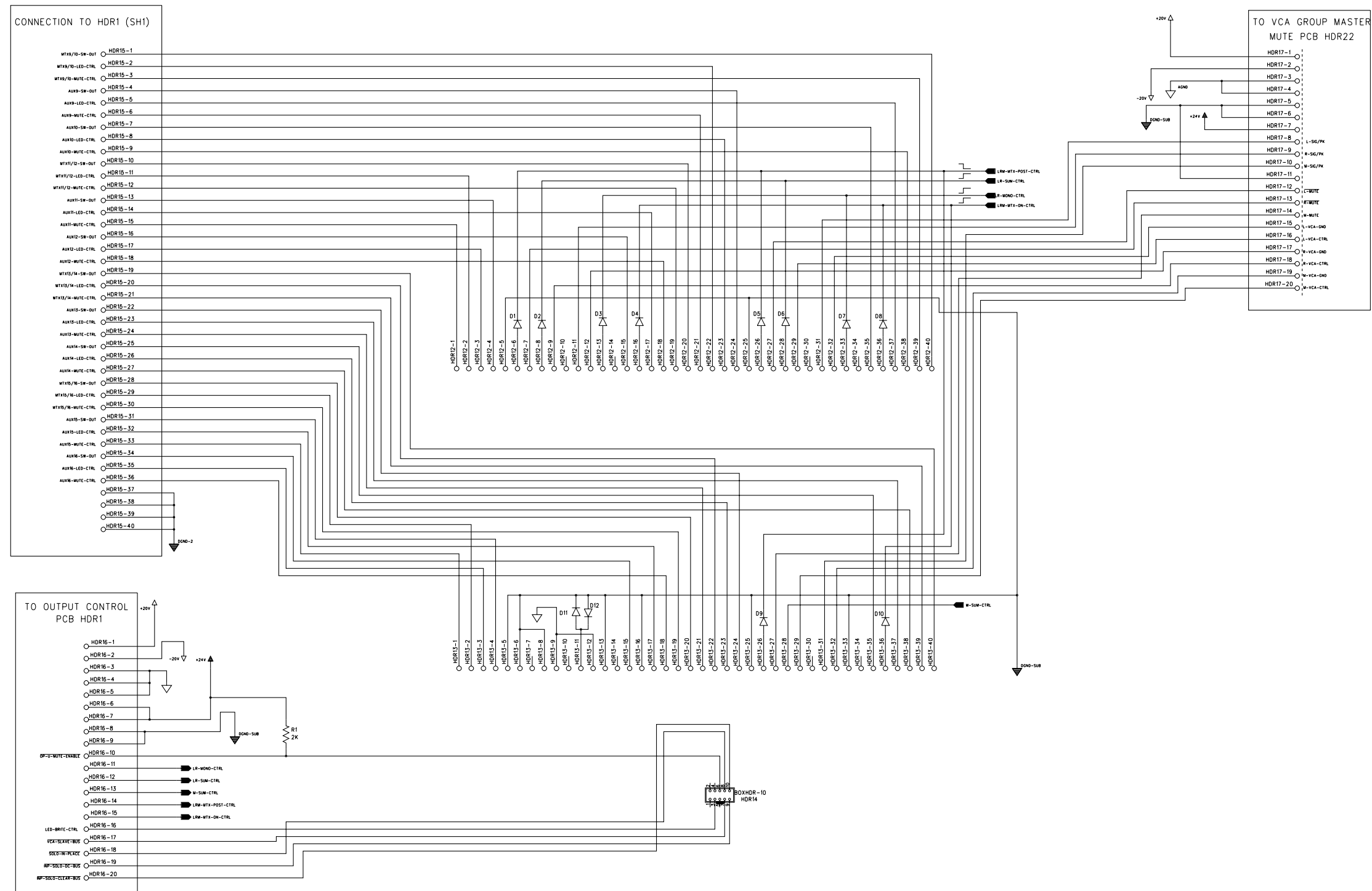

continued on next page

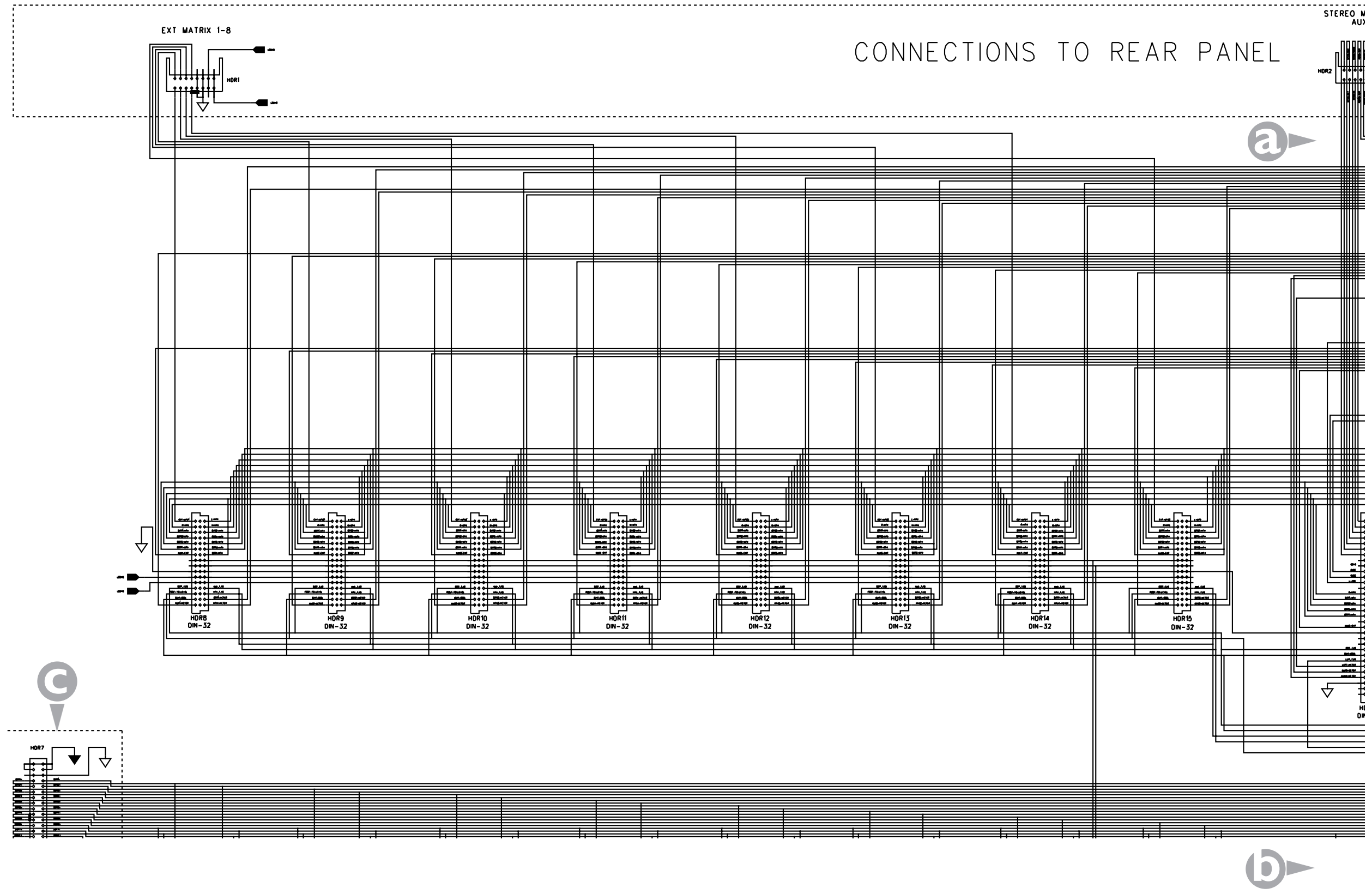

continued from previous page

CONNECTIONS TO REAR PANEL

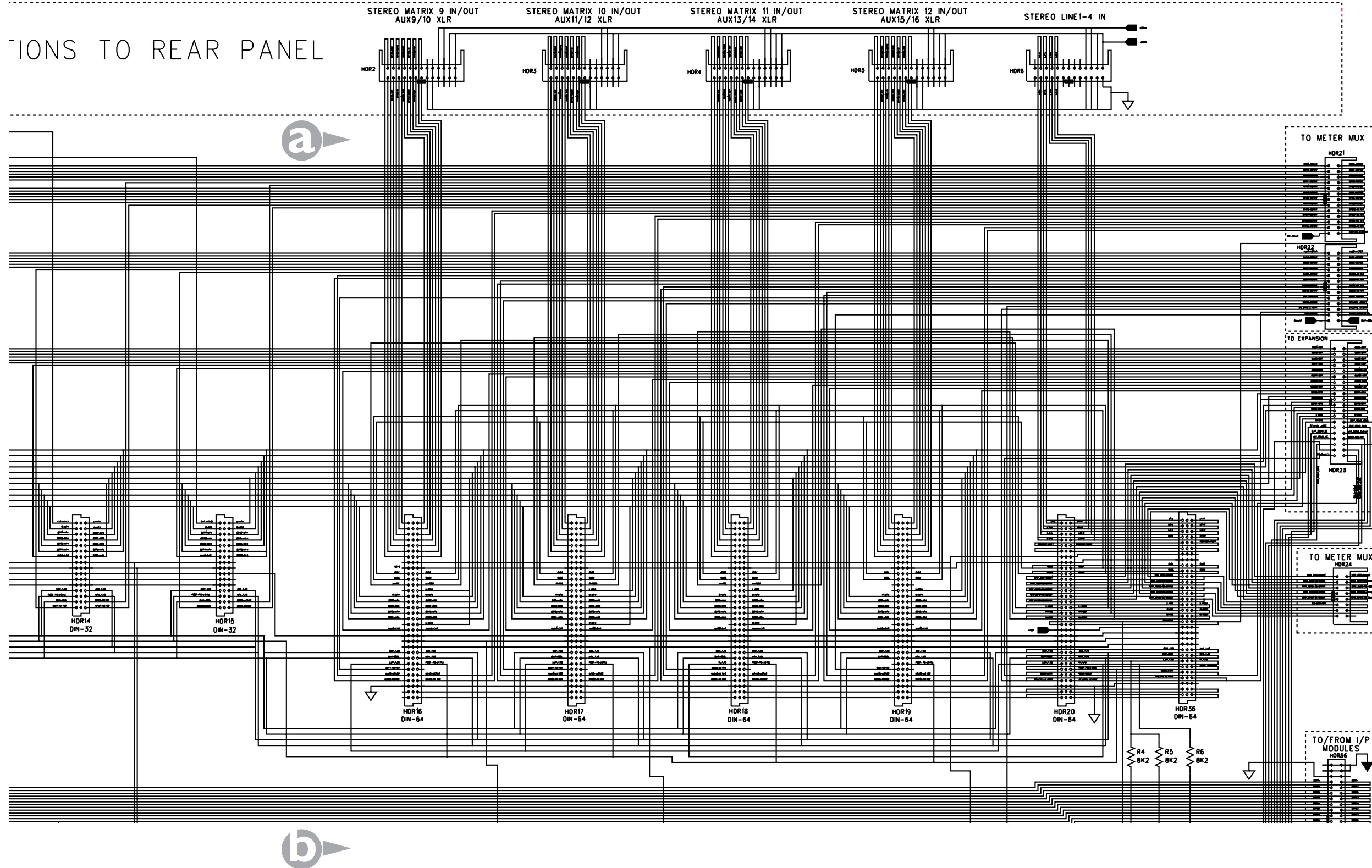

12

continued from previous page

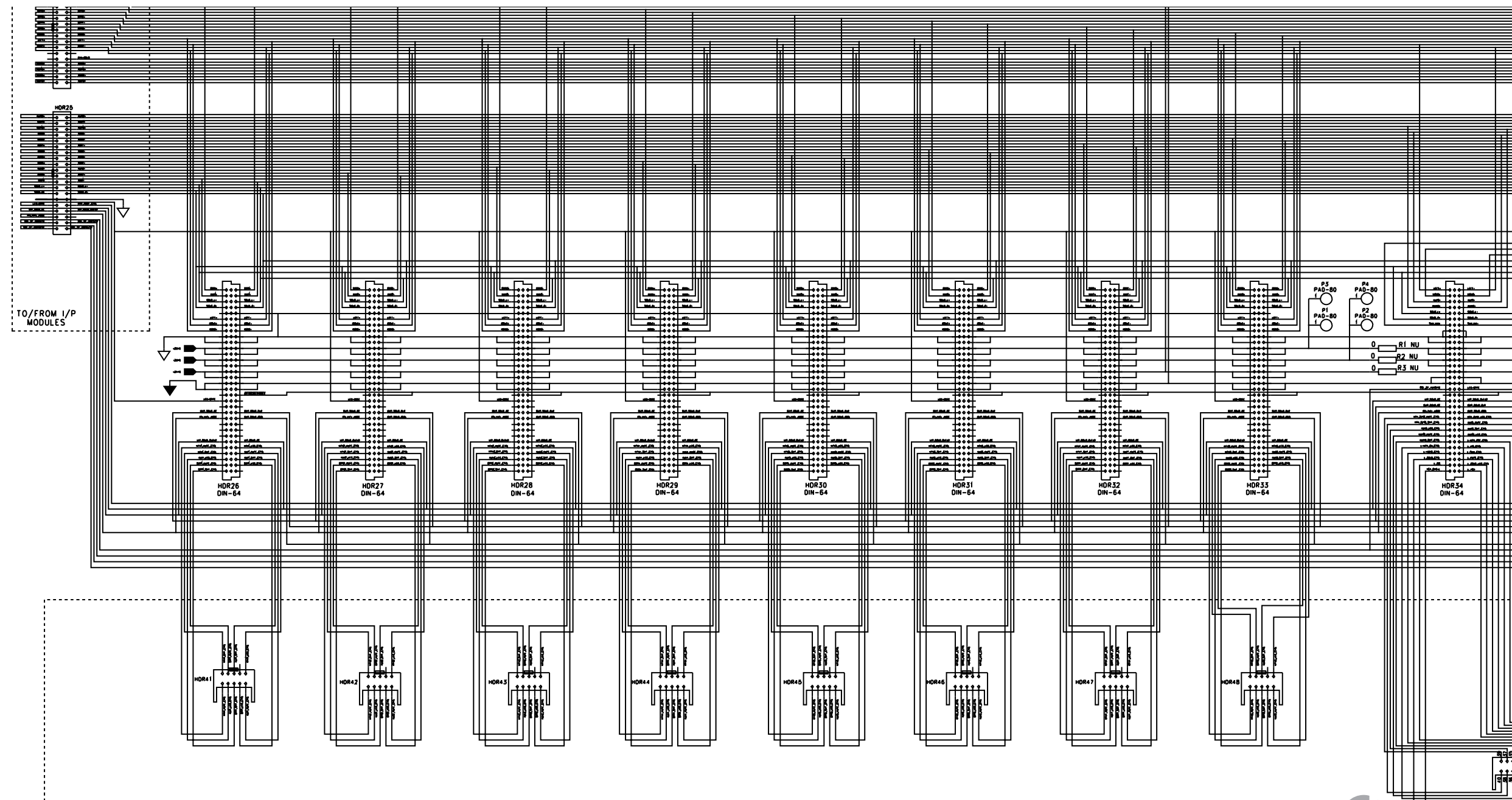

12

CONNECTIONS TO FADER SECTION

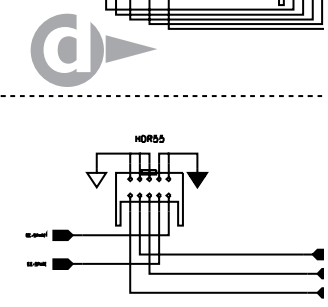
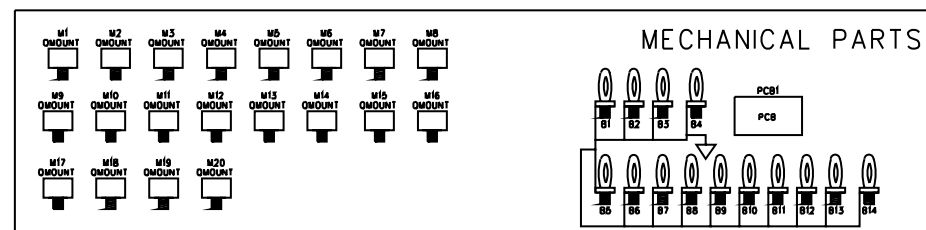

continued from previous page

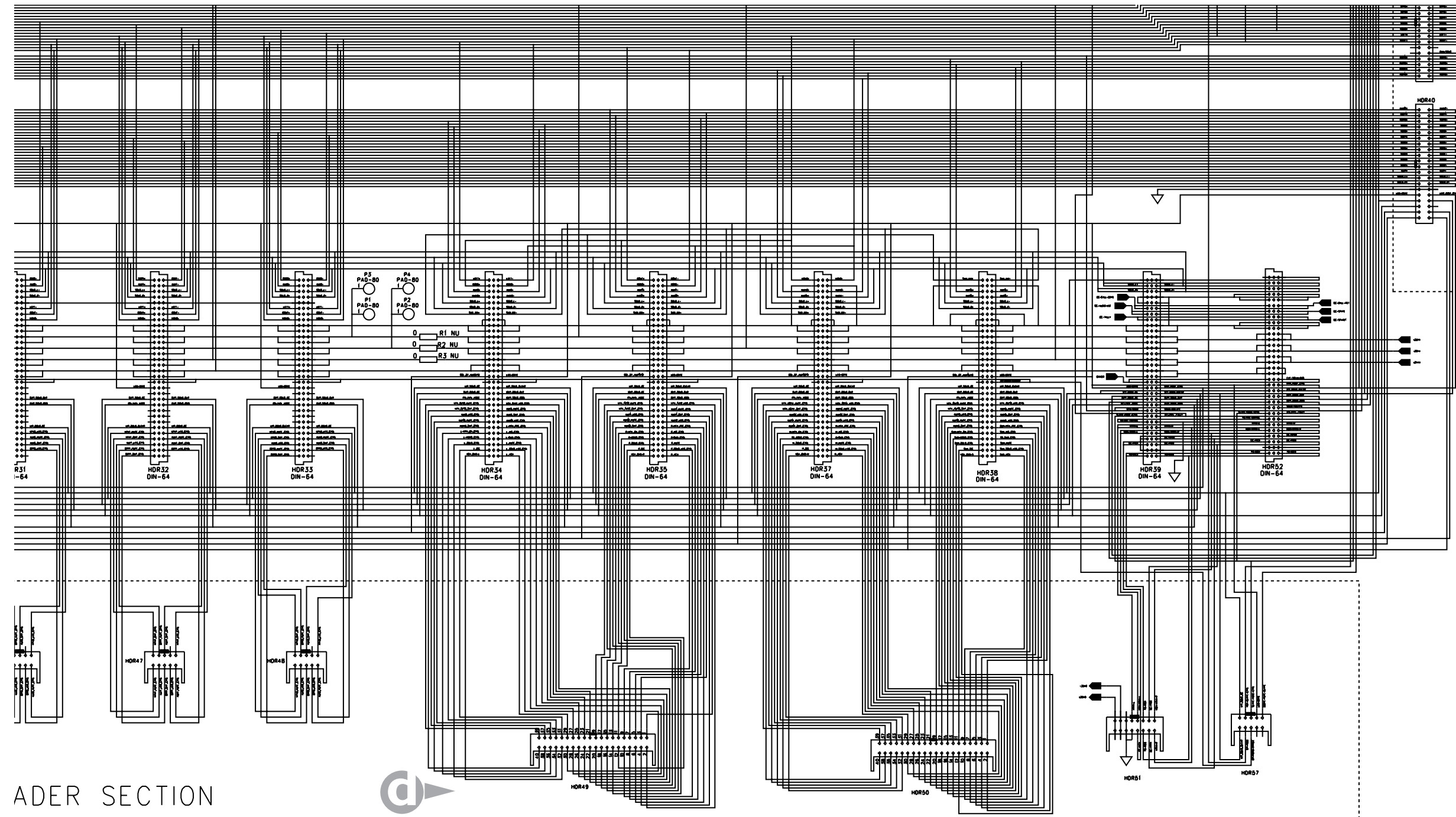

ADER SECTION

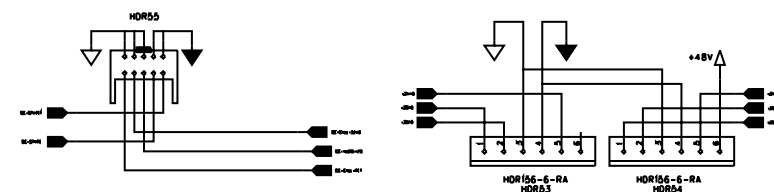

continued on next page

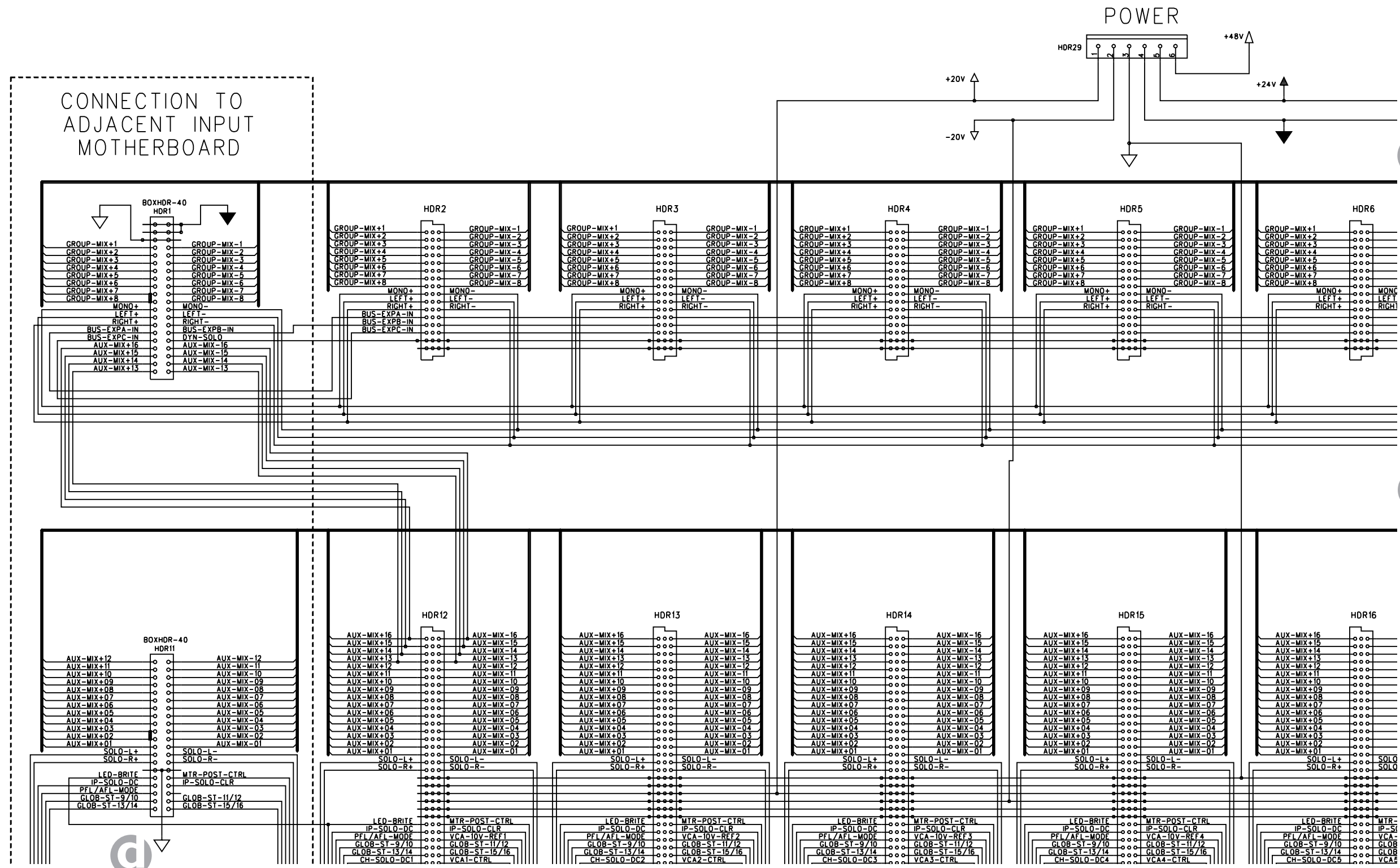

continued from previous page

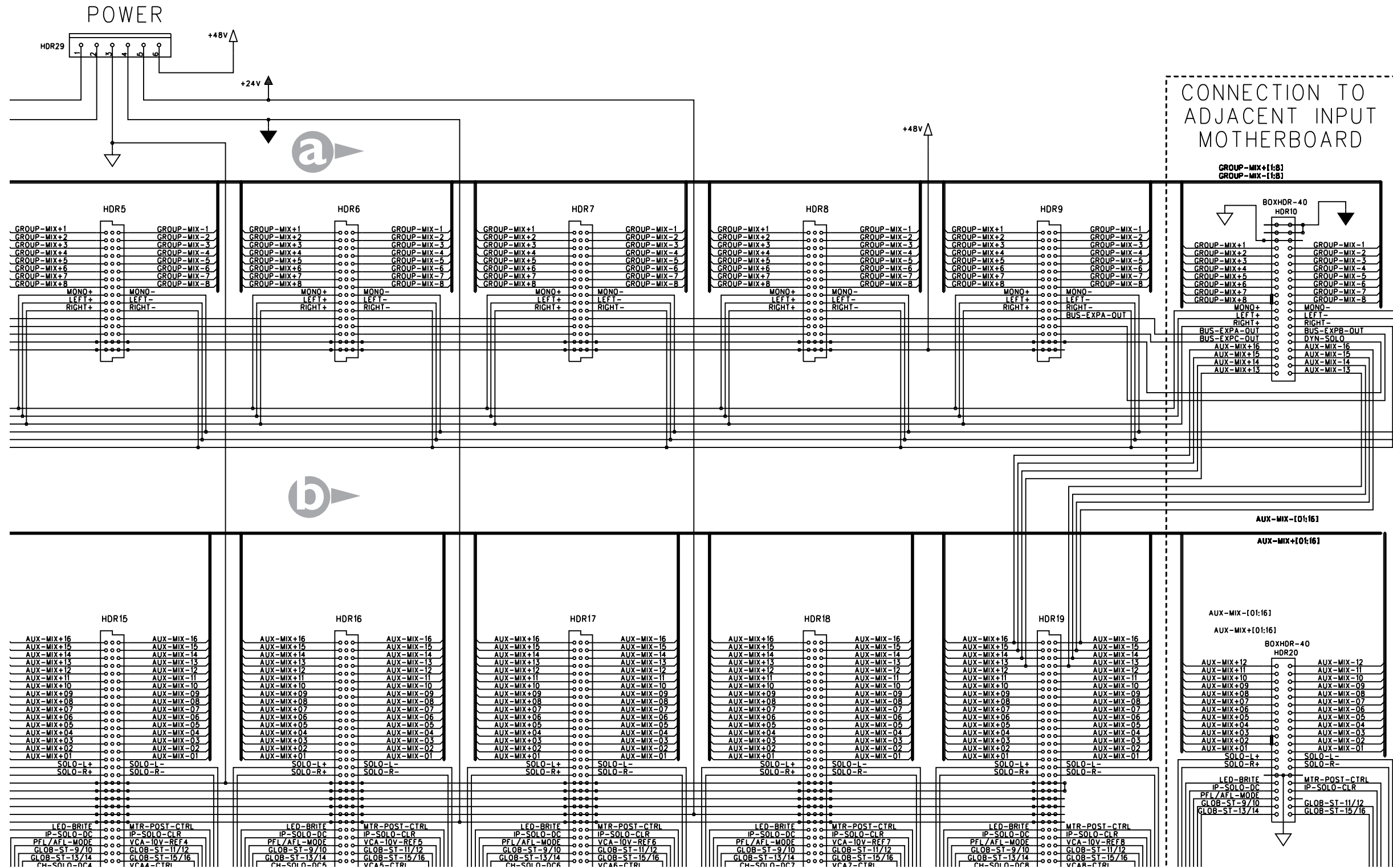

continued from previous page

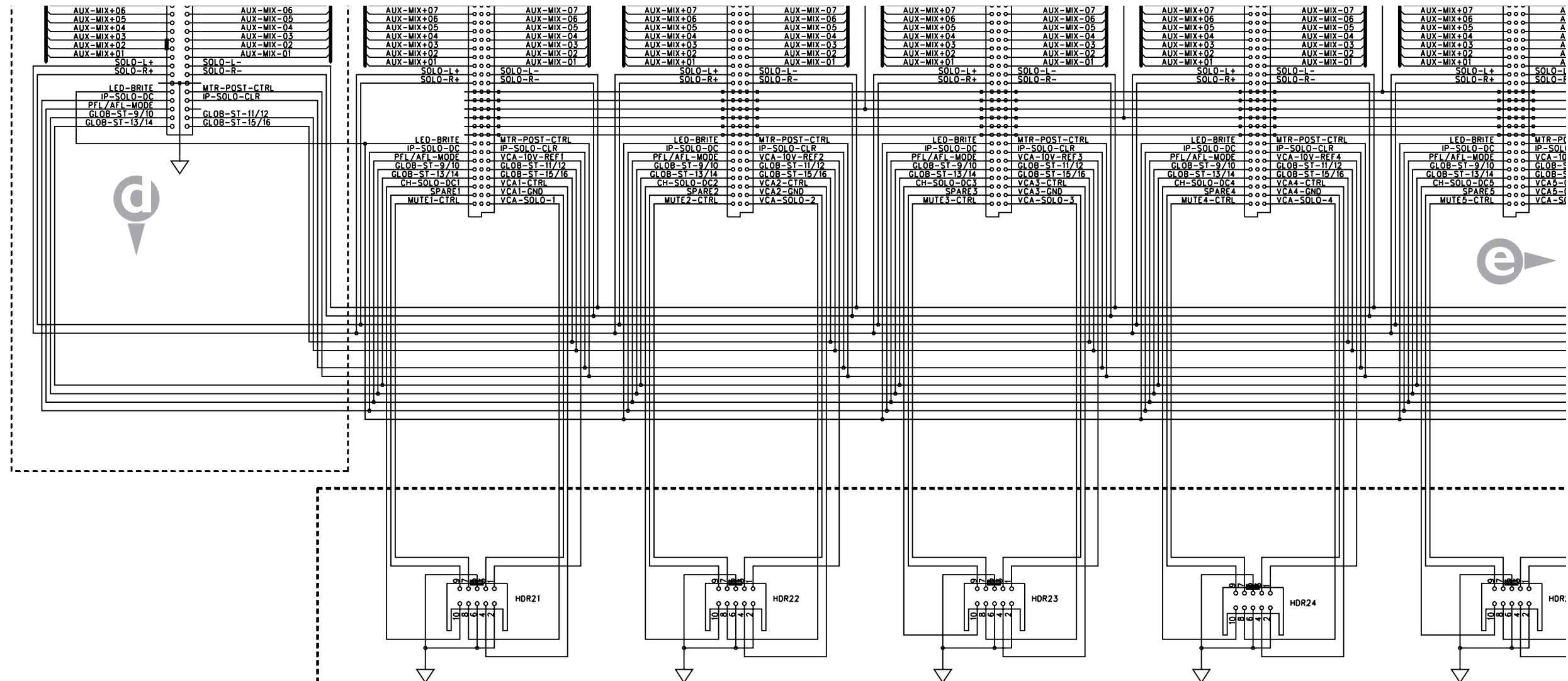

CONNECTIONS TO FADER SECTION

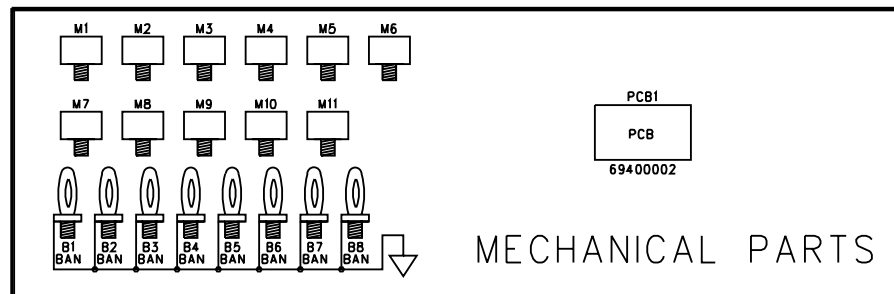

MECHANICAL PARTS

DC0852 - REV CAHNGE FROM B TO C
VCA CTRL POSITION 8 SHORTING
WITH GROUND BRACKET.

continued from previous page

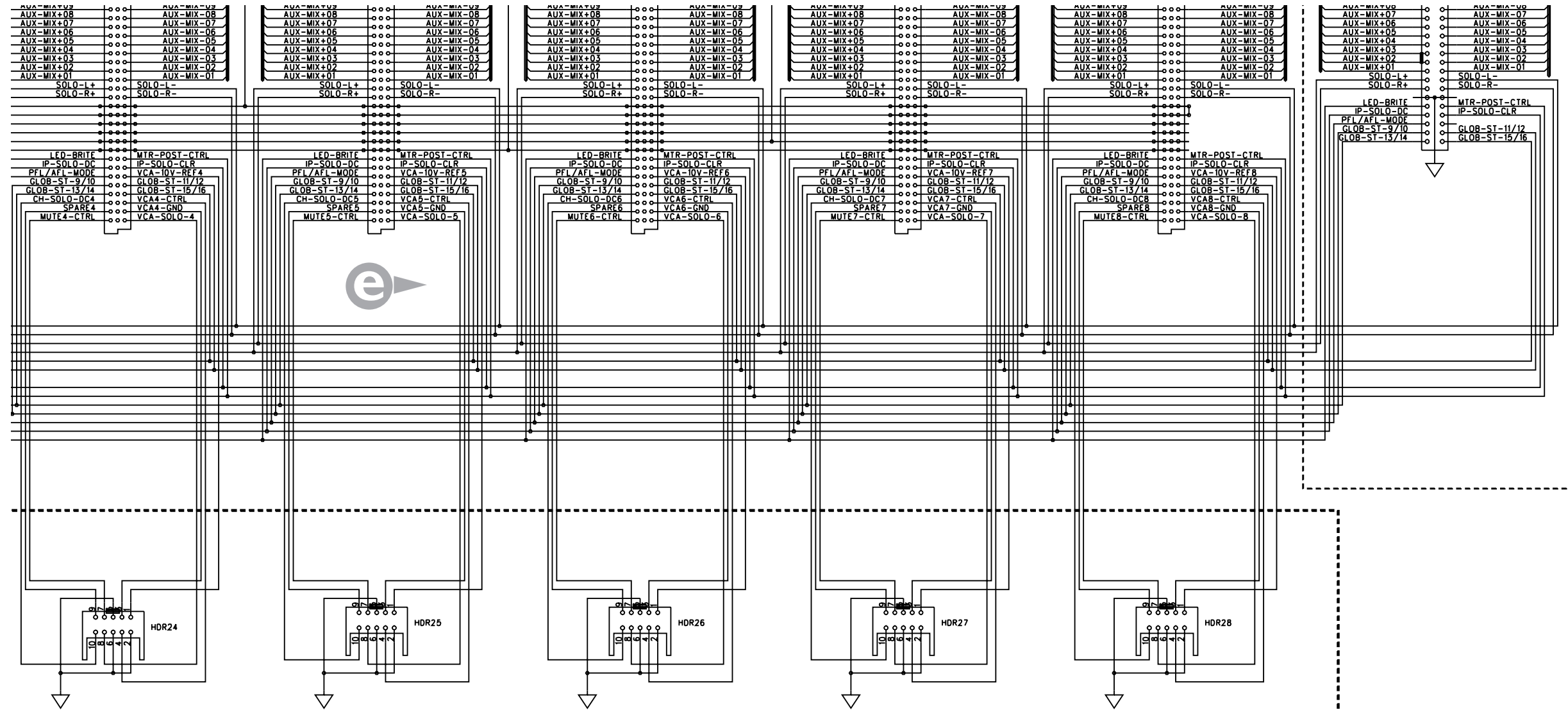

CTIONS TO FADER SECTION

continued on next page

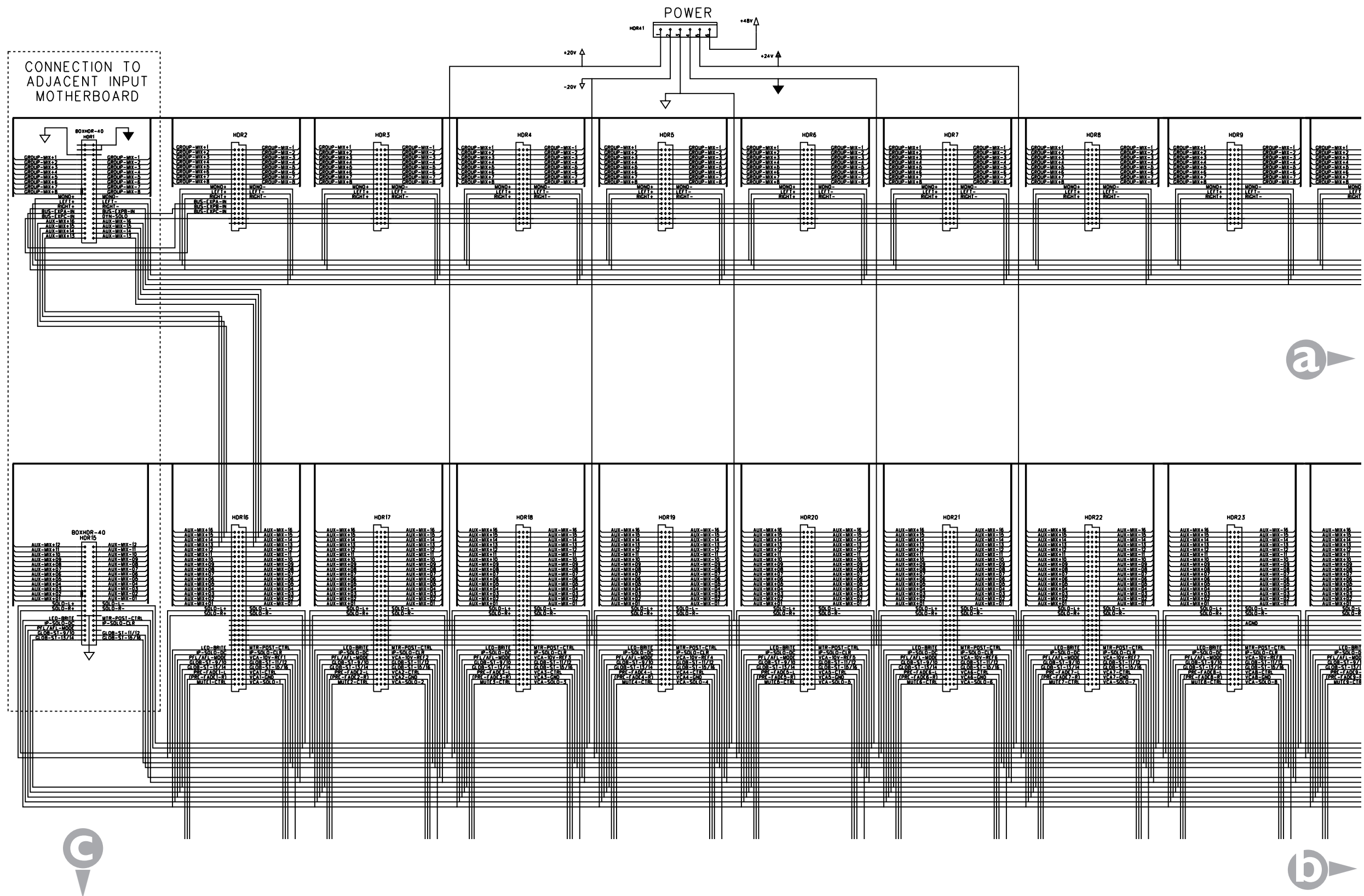

continued from previous page

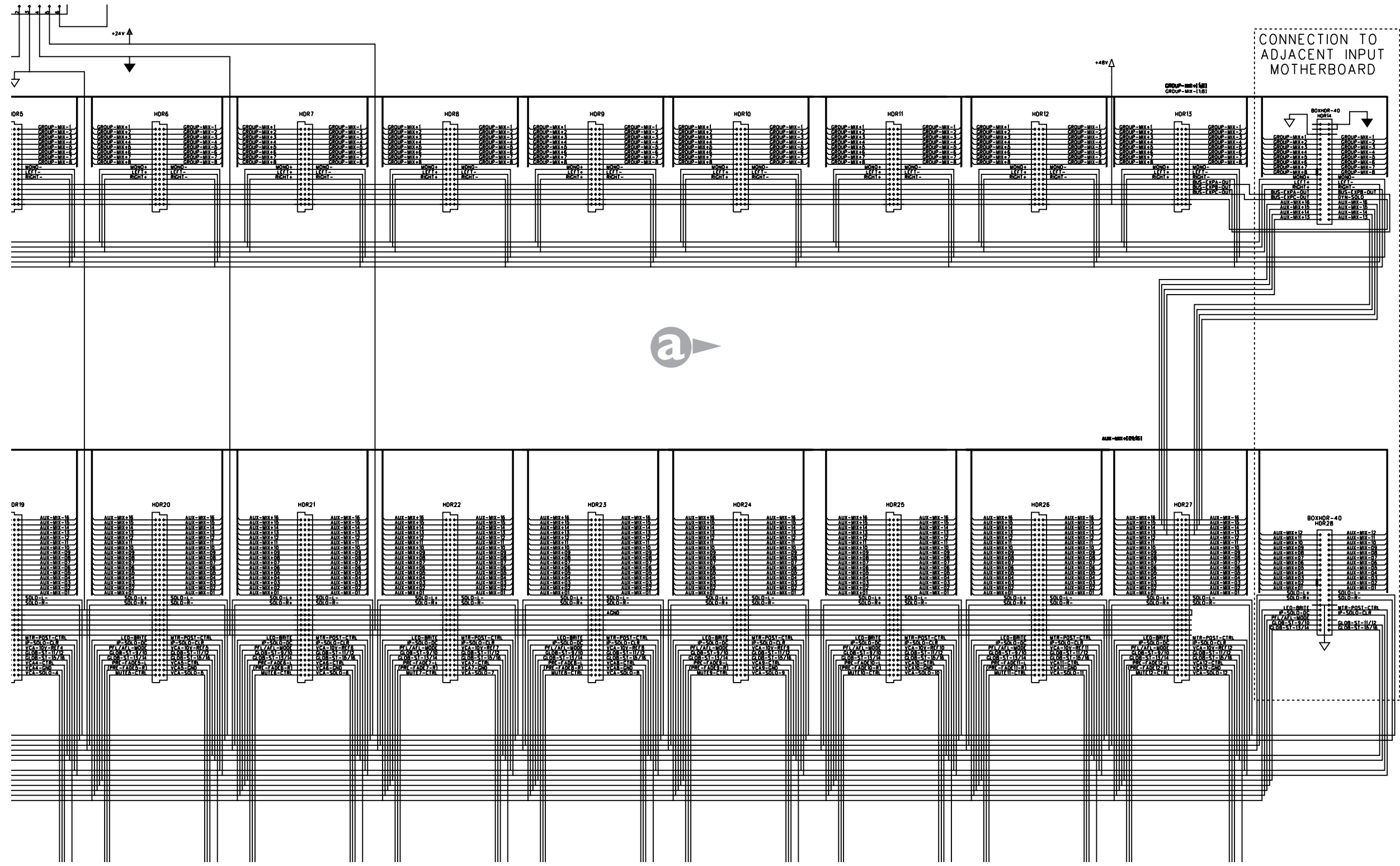

continued from previous page

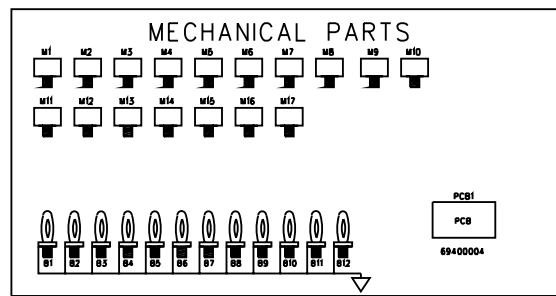
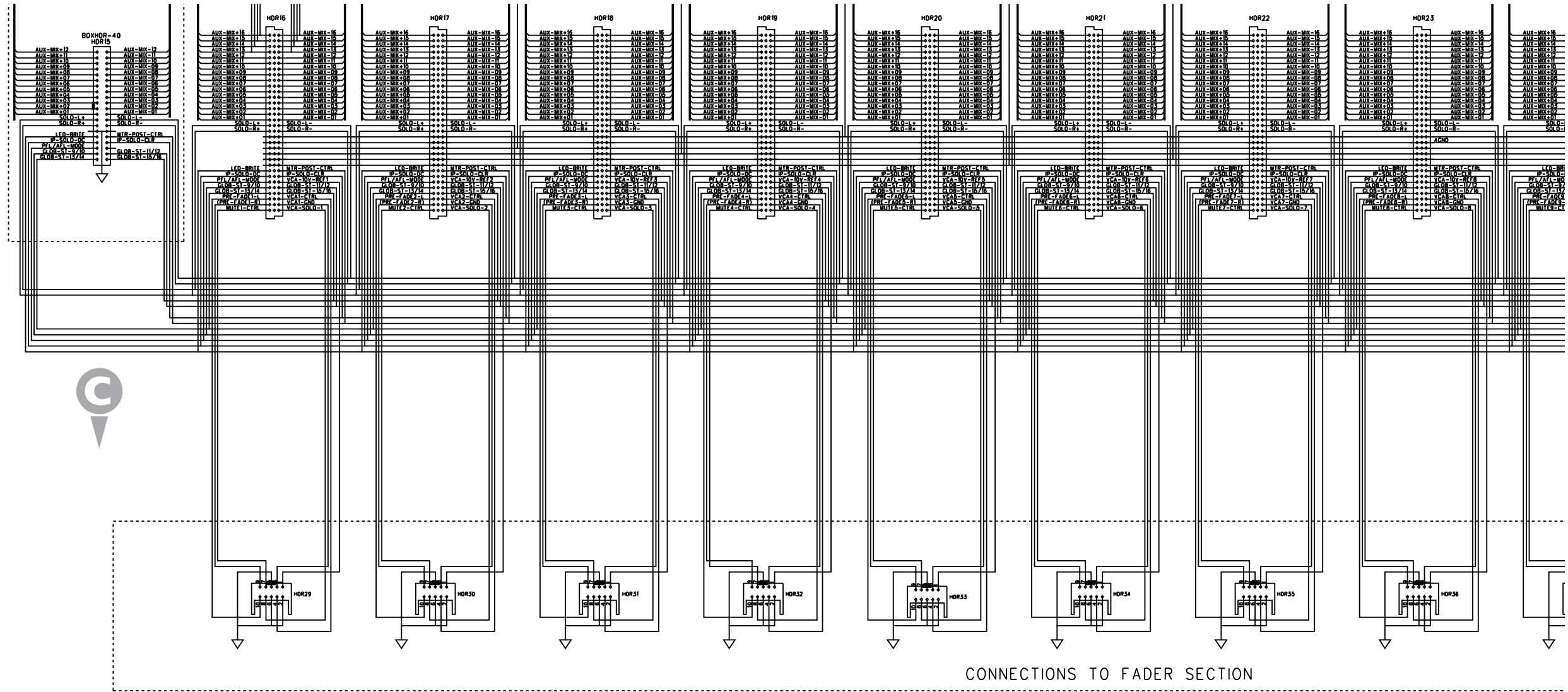

CONNECTIONS TO FADER SECTION

continued from previous page

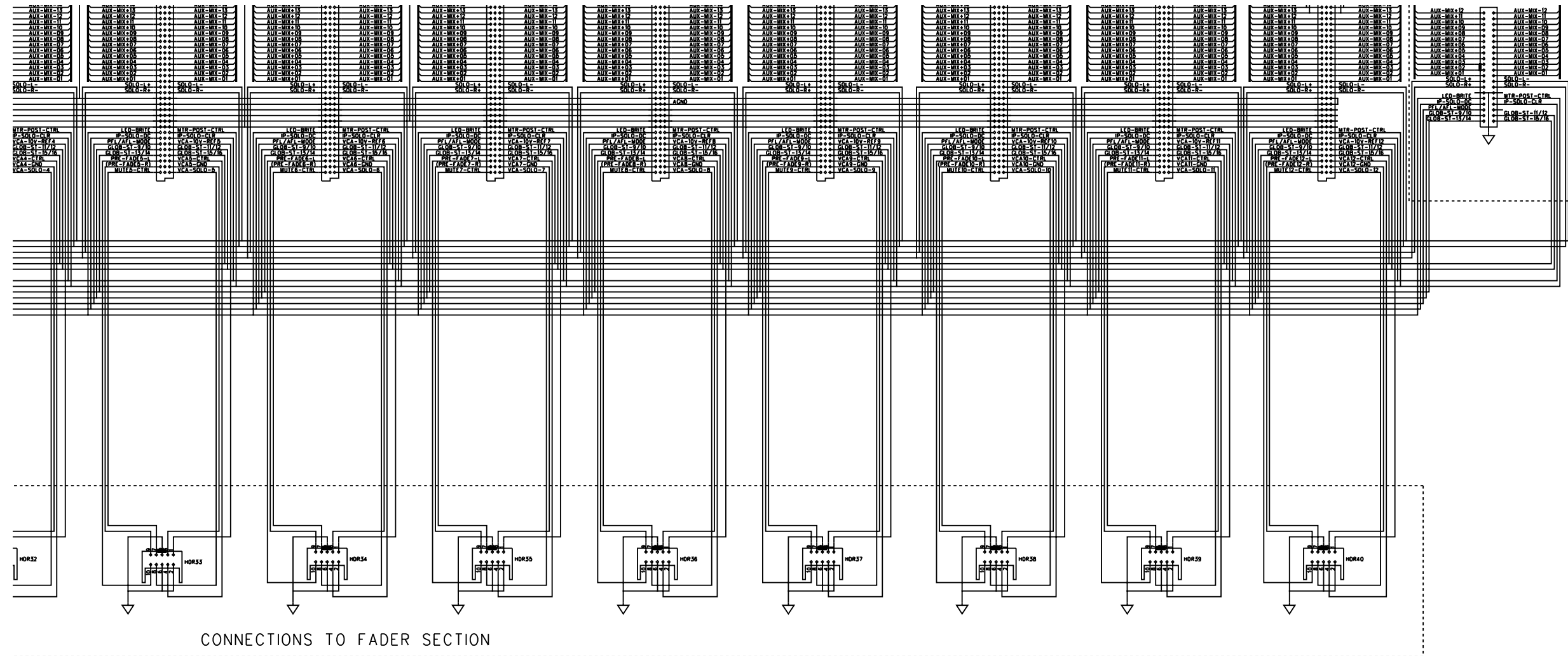

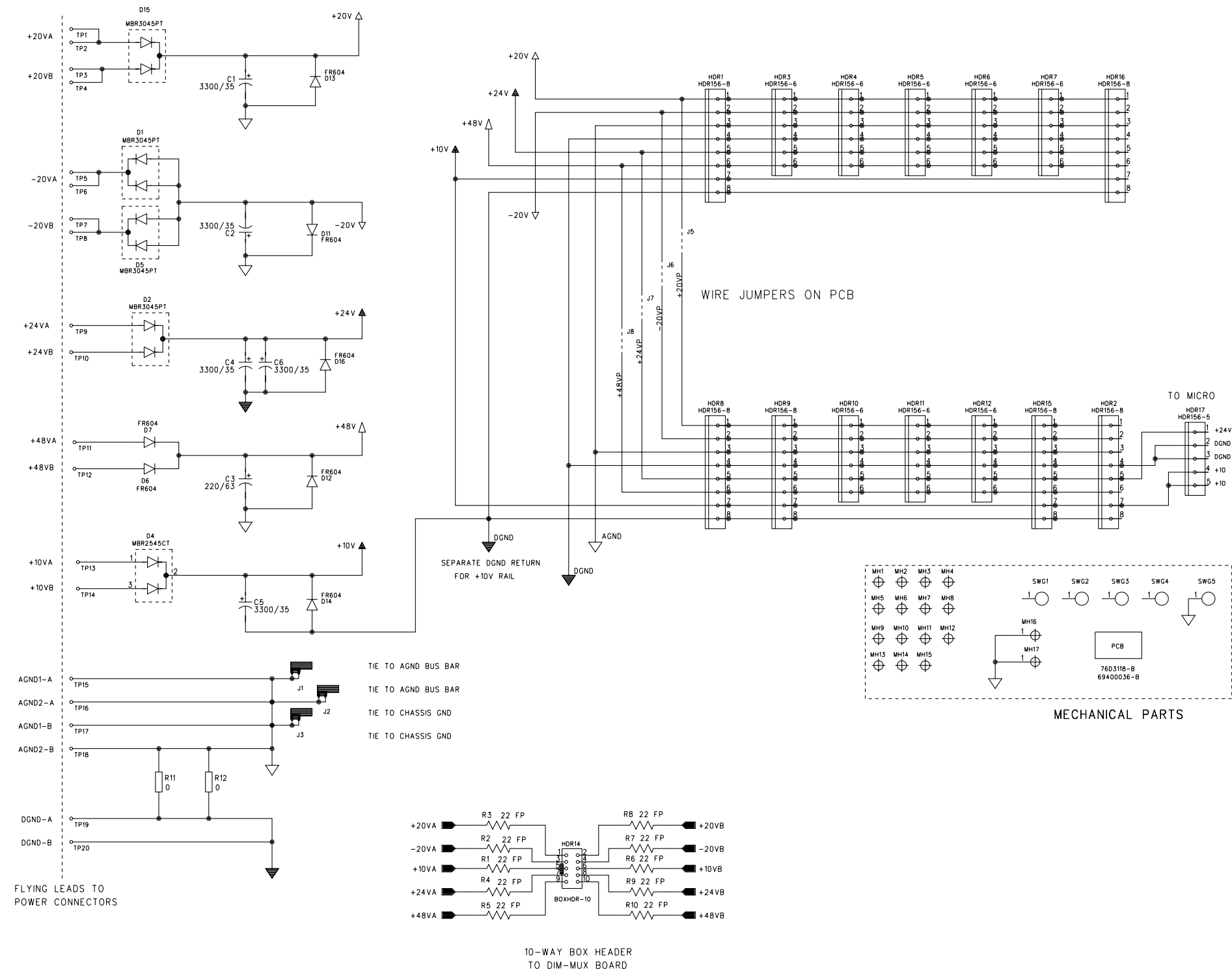

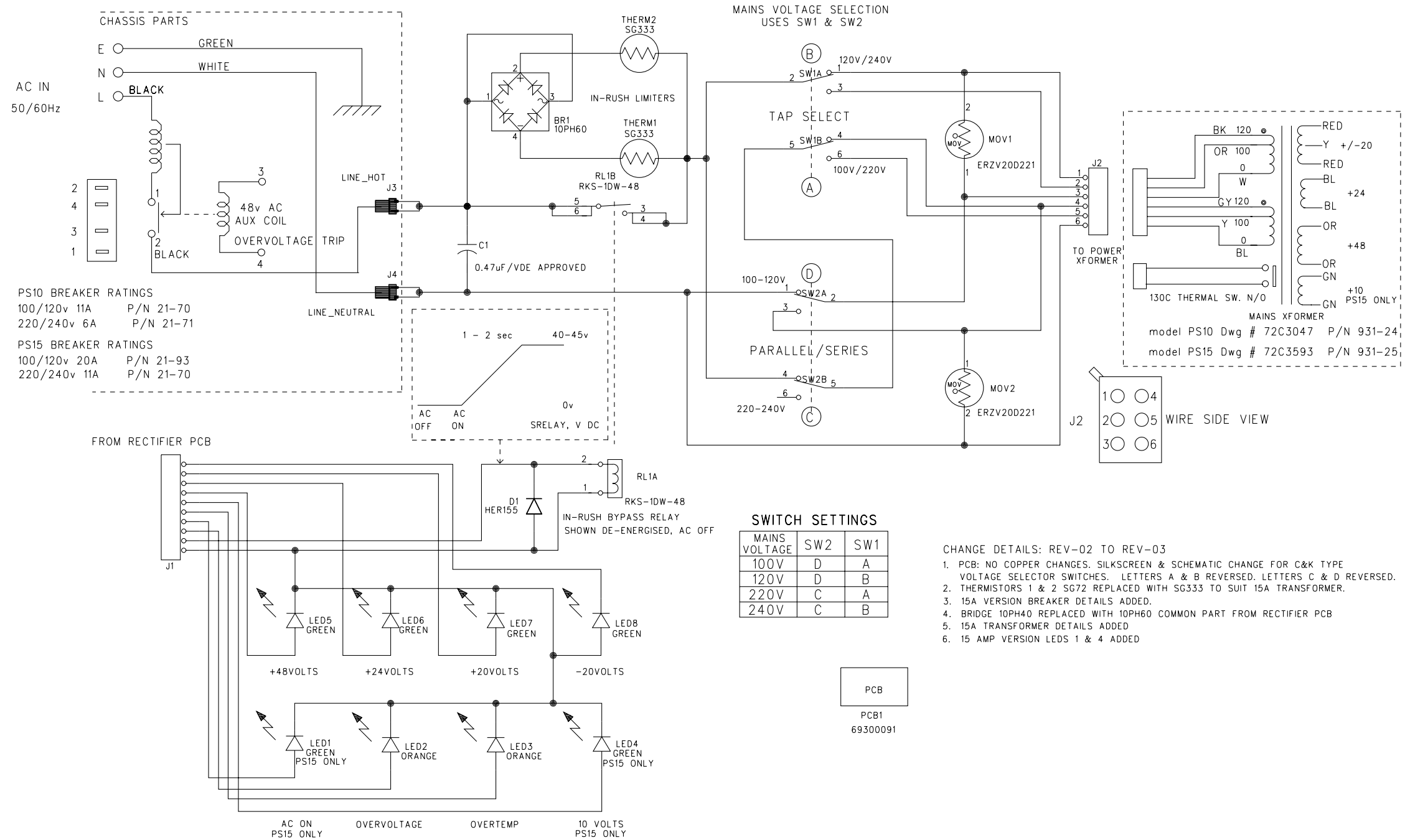

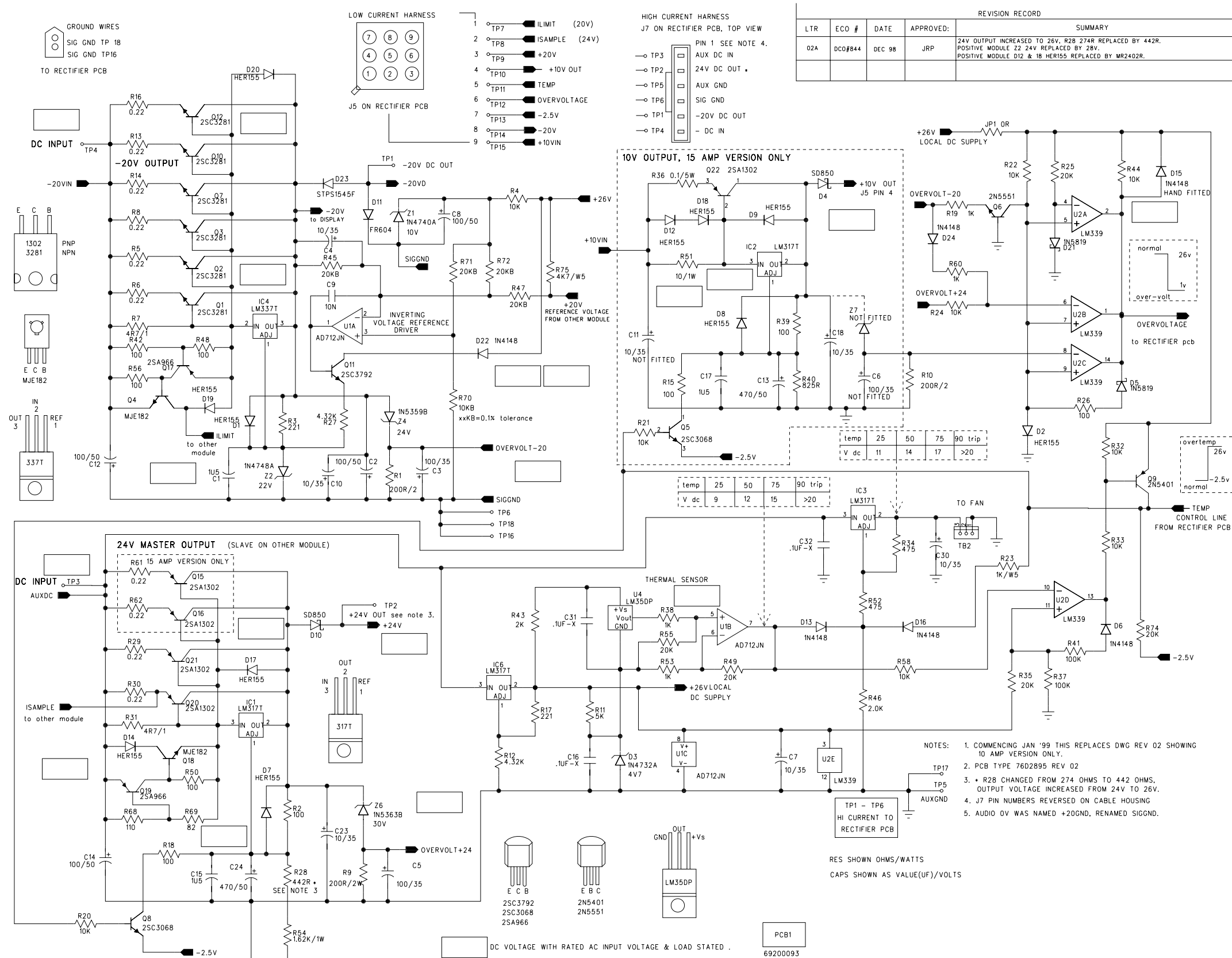

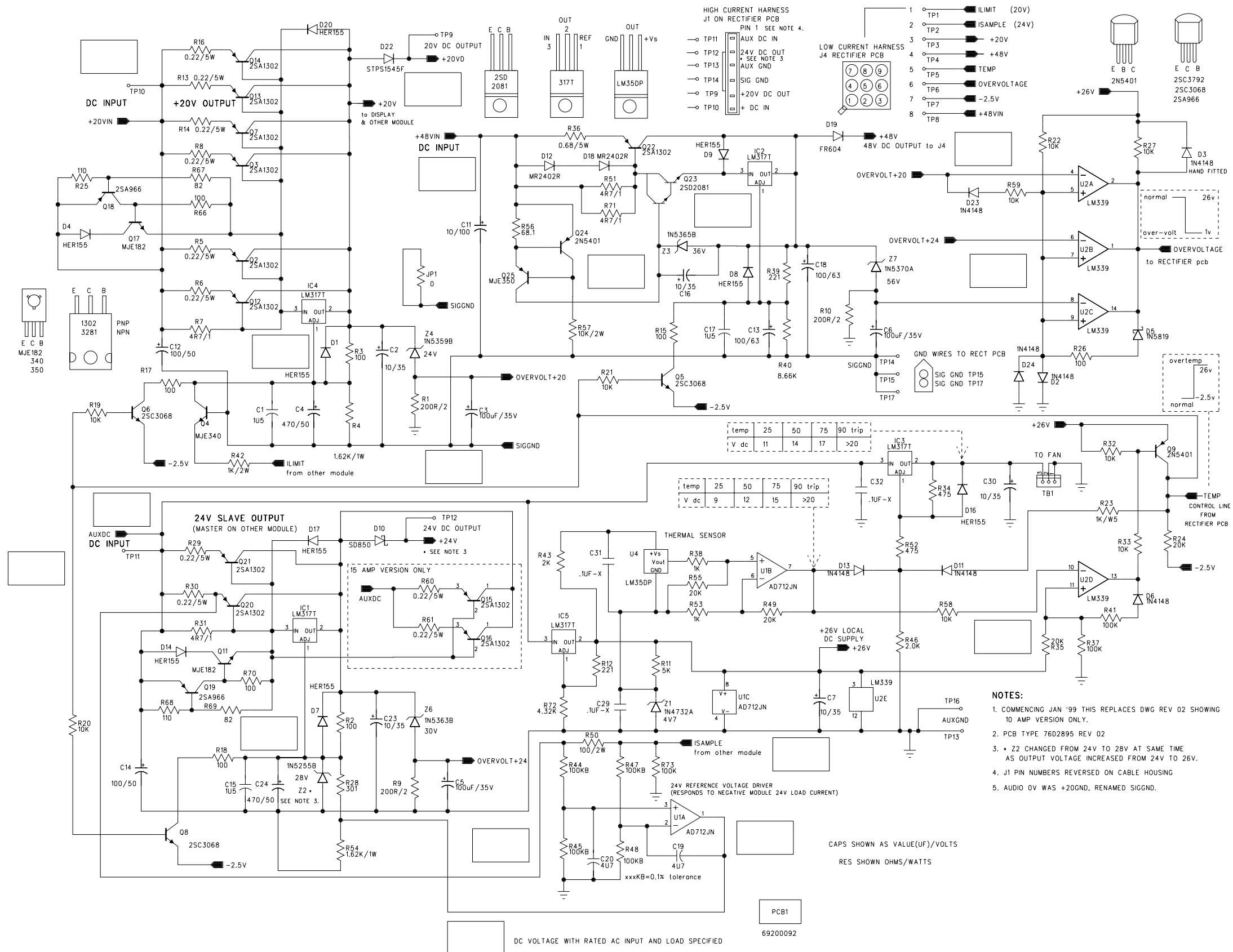

- NOTES:**
1. COMMENCING JAN '99 THIS REPLACES DWG REV 02 SHOWING 10 AMP VERSION ONLY.
 2. PCB TYPE 76D2895 REV 02
 3. Z2 CHANGED FROM 24V TO 28V AT SAME TIME AS OUTPUT VOLTAGE INCREASED FROM 24V TO 26V.
 4. J1 PIN NUMBERS REVERSED ON CABLE HOUSING
 5. AUDIO 0V WAS +20GND, RENAMED SIGGND.

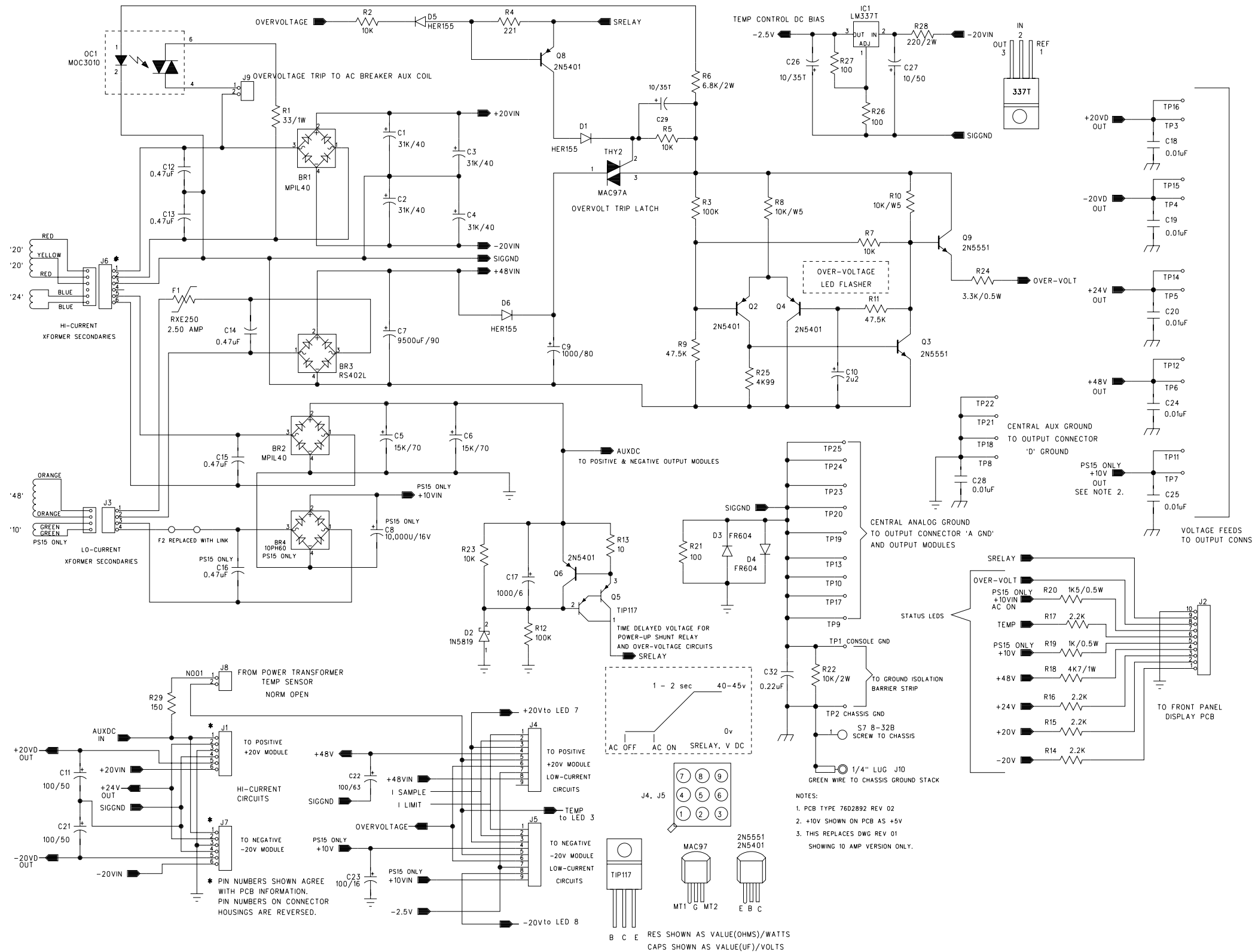



v. 1.0 ED000V12 10/12/99

Crest Audio Inc.
100 Eisenhower Dr., Paramus NJ 07652 USA
TEL: 201.909.8700 FAX: 201.909.8744
www.crestaudio.com